

Tetraedro ed Ottaedro con tessere triangolari

1

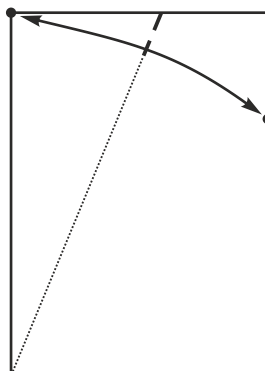

2



3

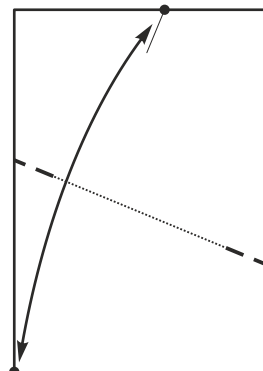

4

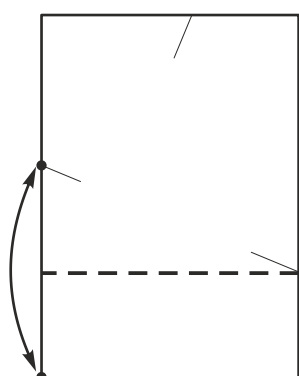

5

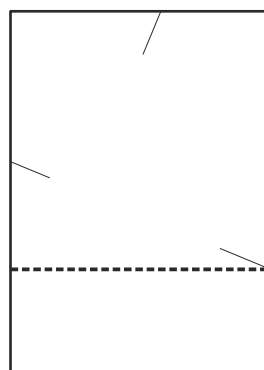

6

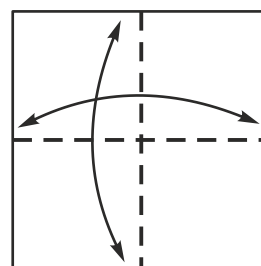

7

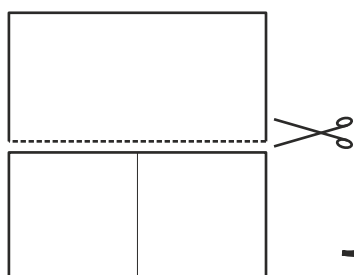

8

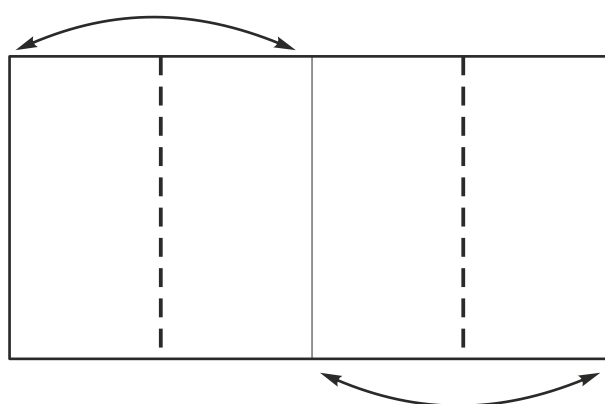

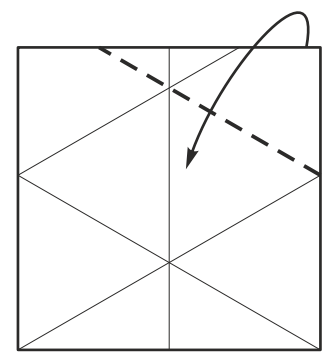
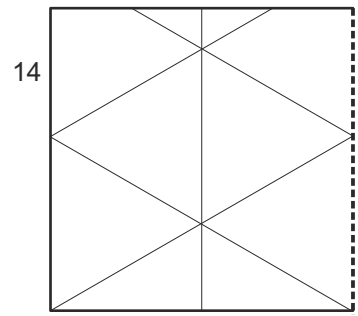
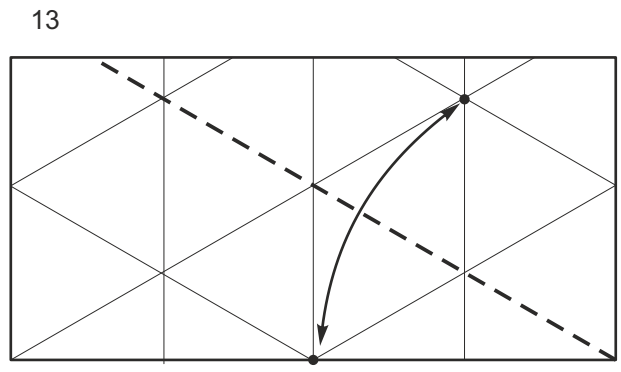
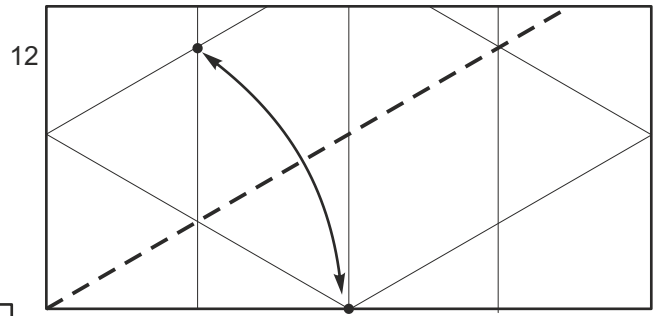
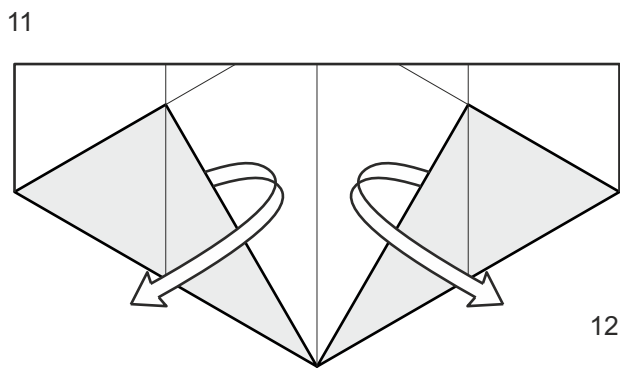
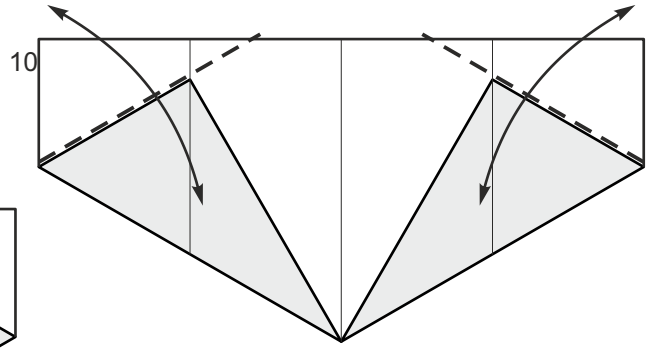
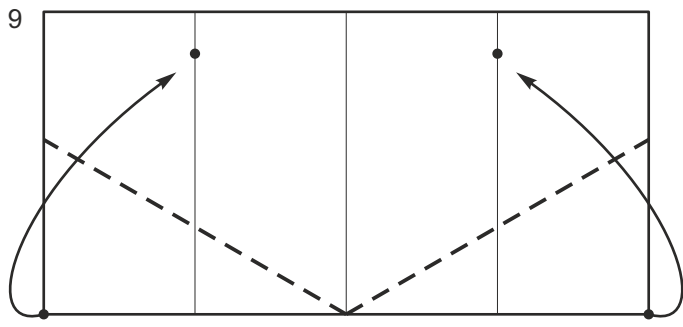

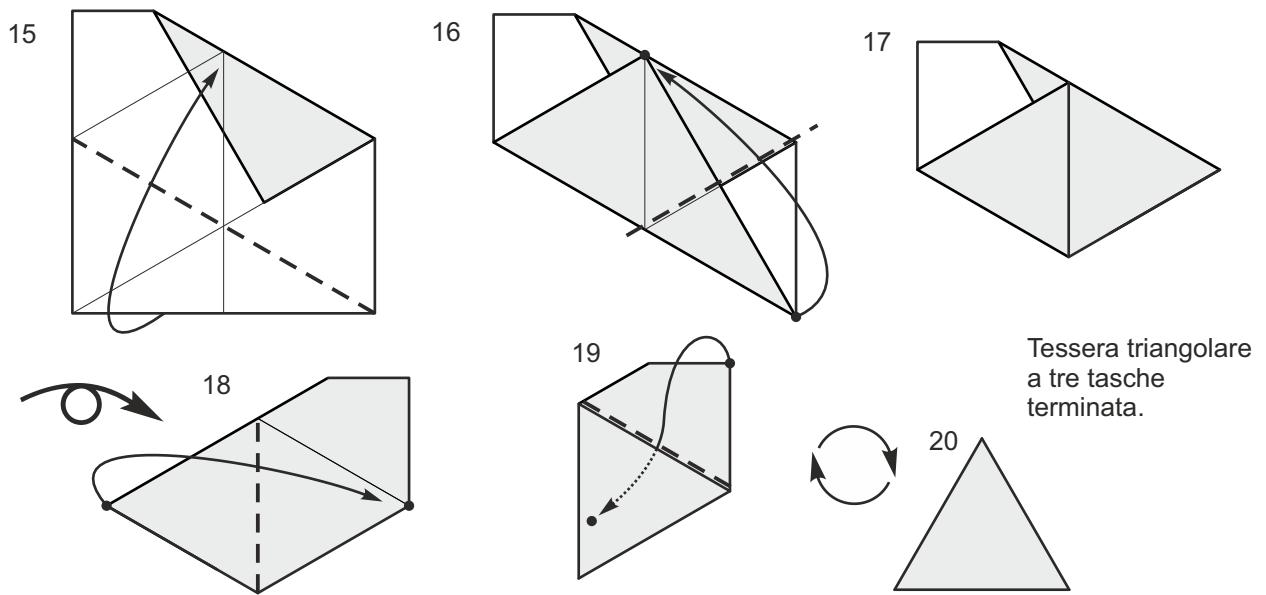

Giunti per unire le tessere triangolari tra loro

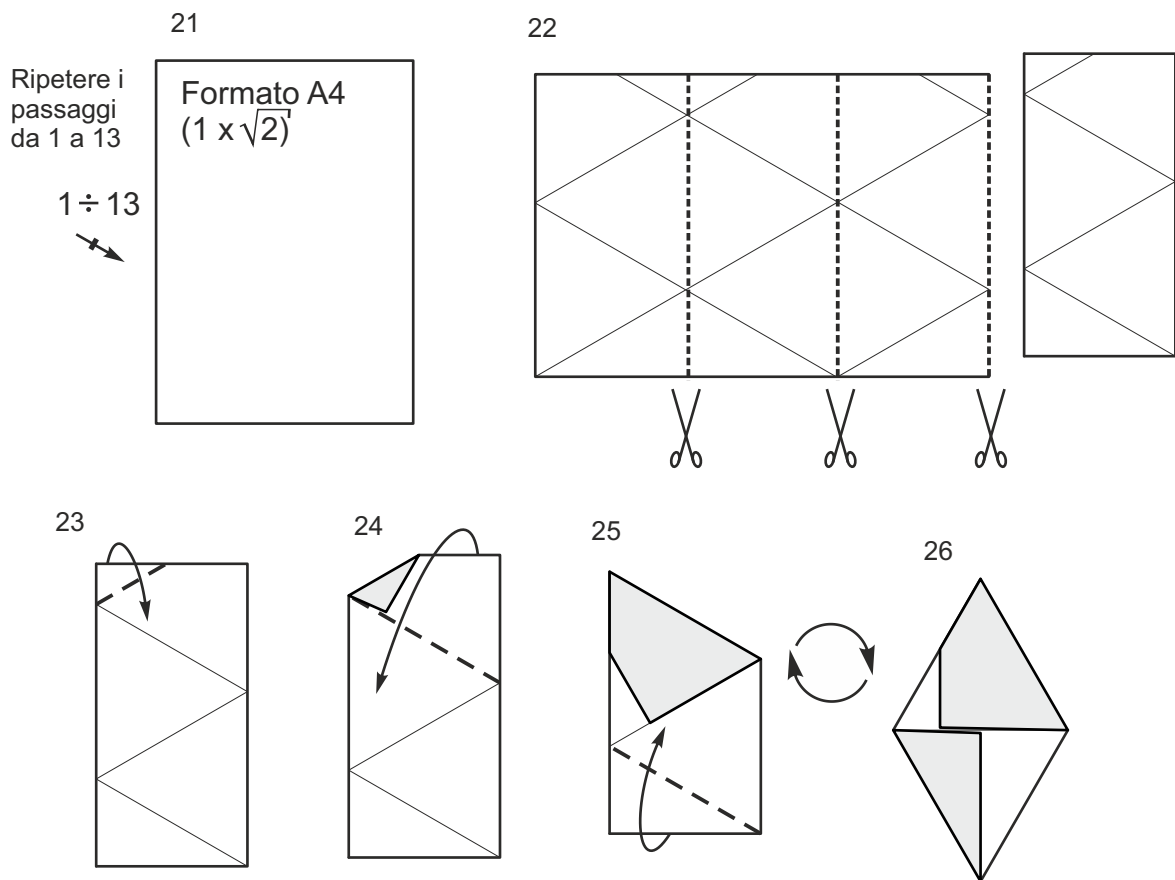

Montaggio del TETRAEDRO.

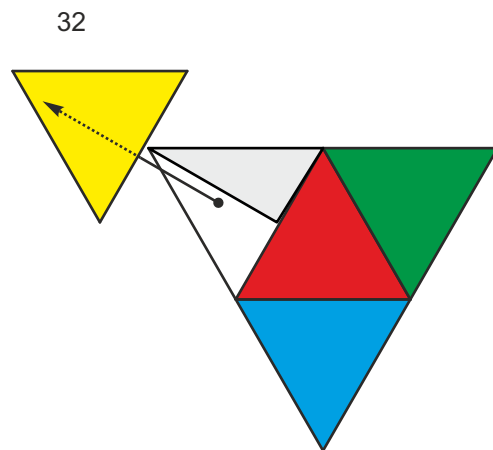
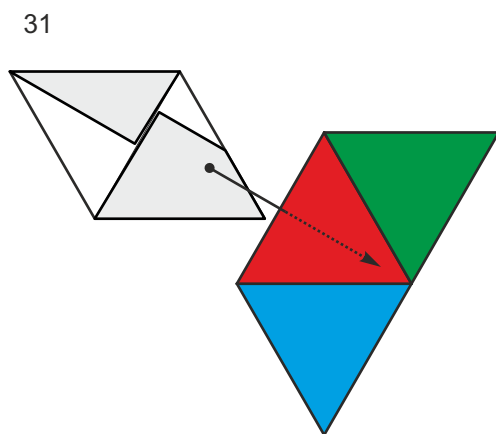
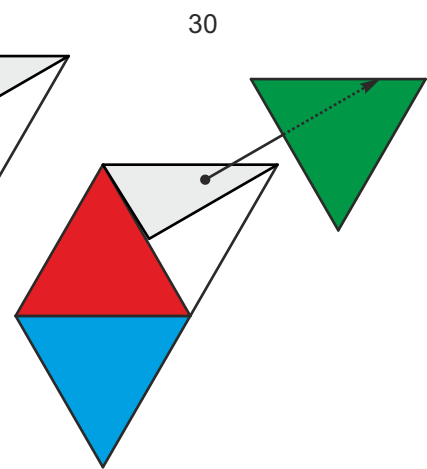
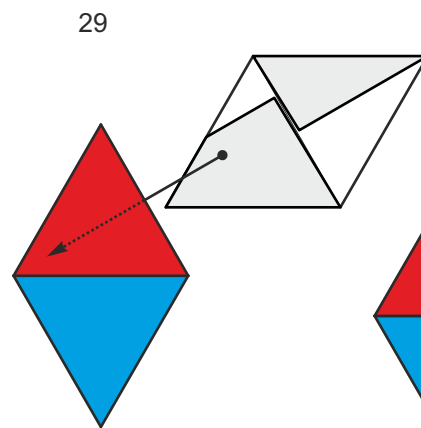
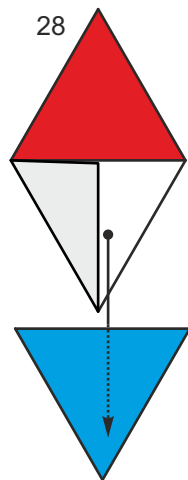
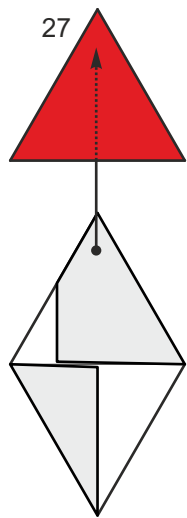
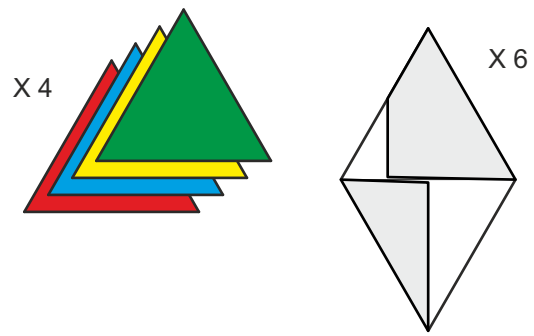

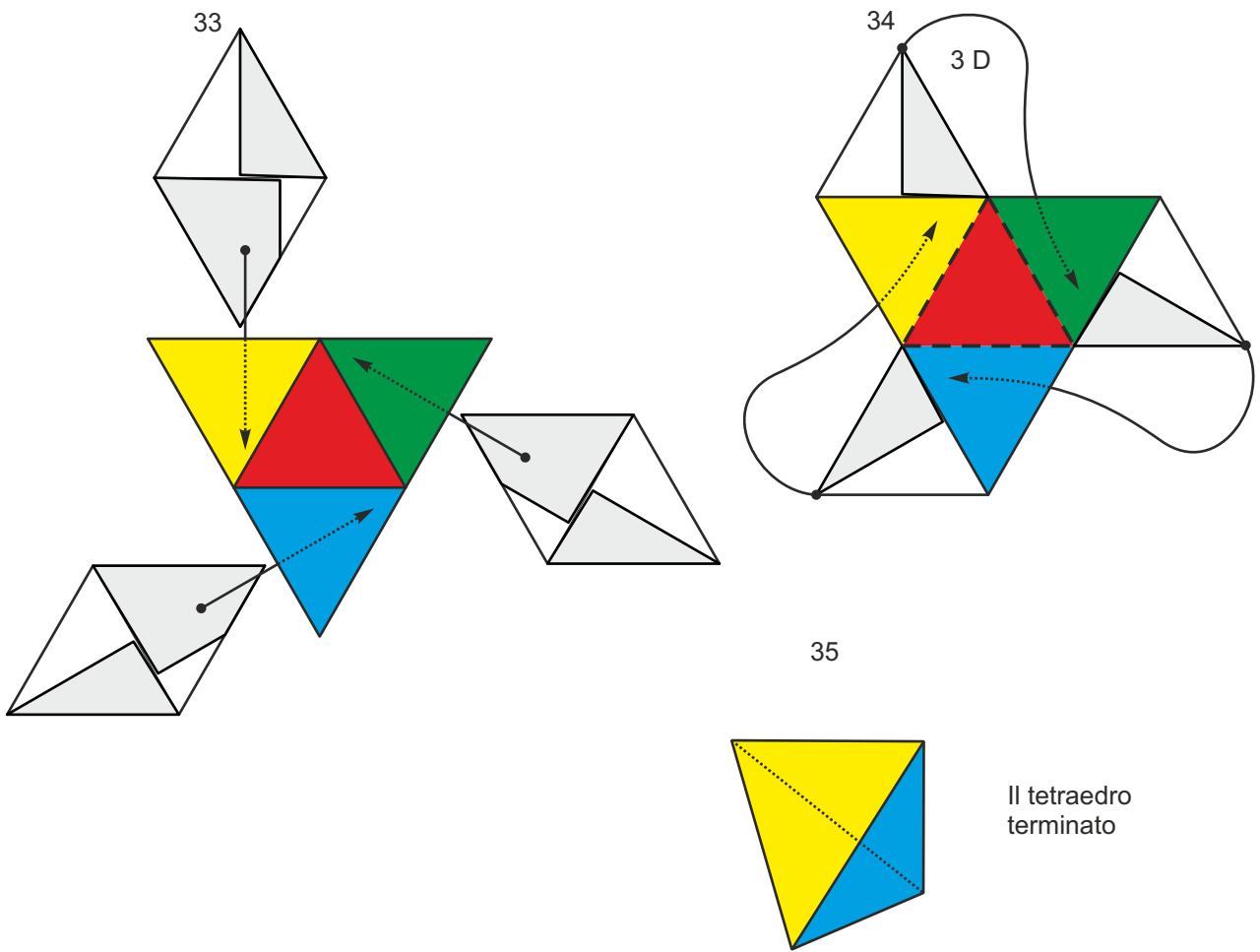

Montaggio dell'Ottaedro

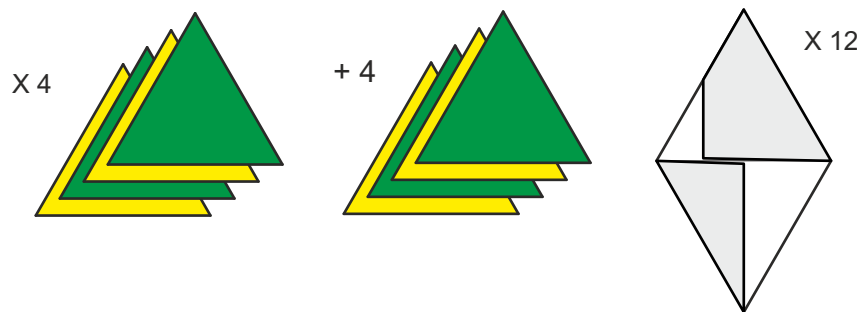

36

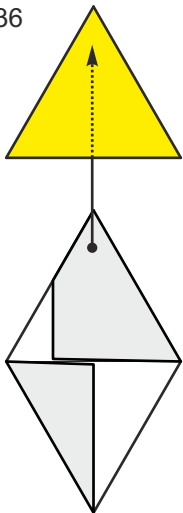

37

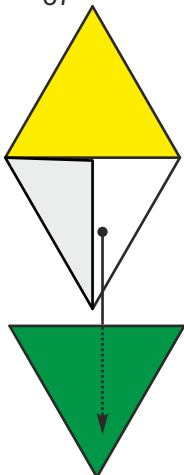

38

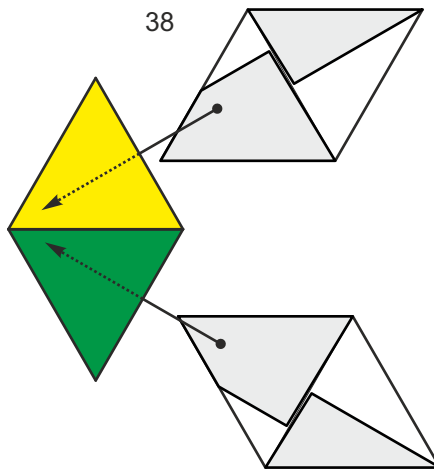

39

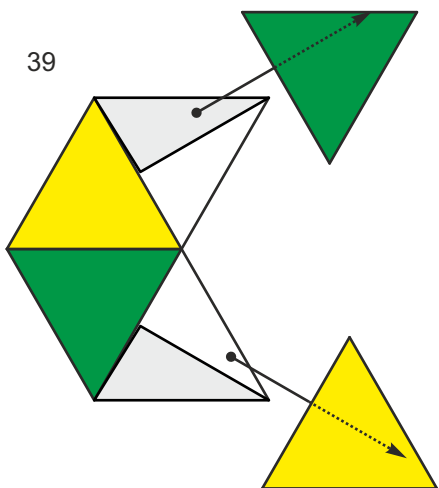

40

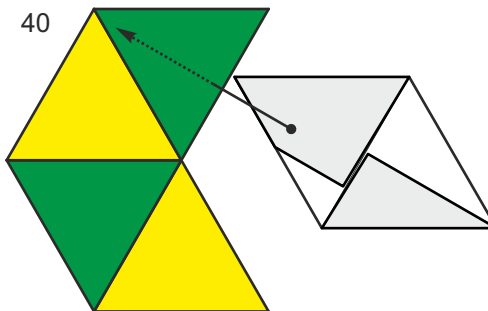

3 D

41

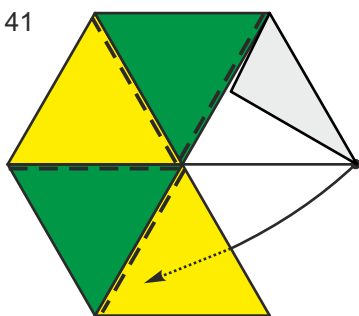

42

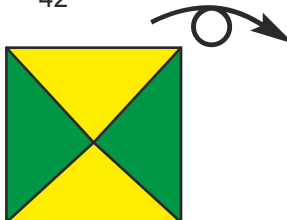

43

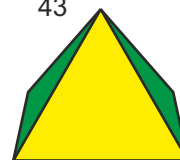

4 tessere corrispondenti
a metà ottaedro
unite tra loro e viste
dalla parte concava

4 tessere unite
tra loro viste
dalla parte convessa

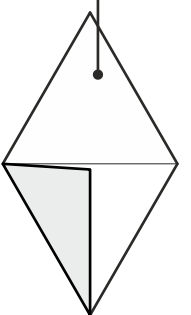
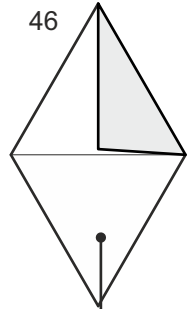
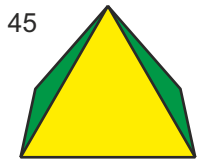

Preparare un secondo pezzo identico al primo

Unione dei due pezzi tra loro per formare l'ottaedro

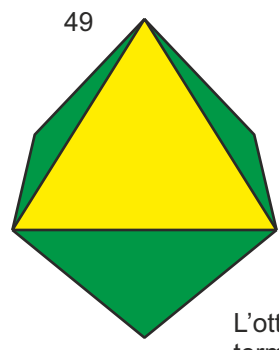
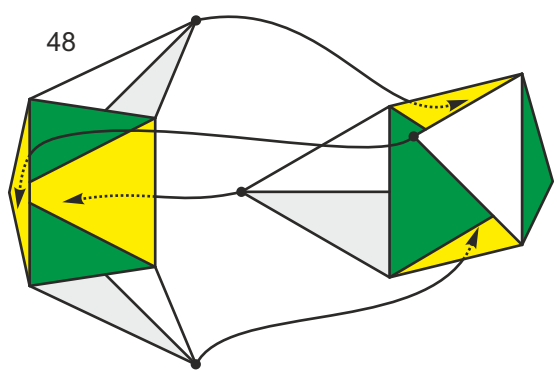

L'ottaedro terminato

Stella Octangula

Preparazione dei giunti «corti» tipo 2

Partire dal n. 5

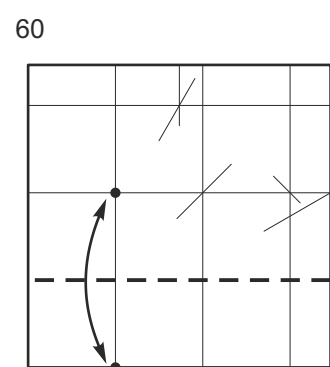
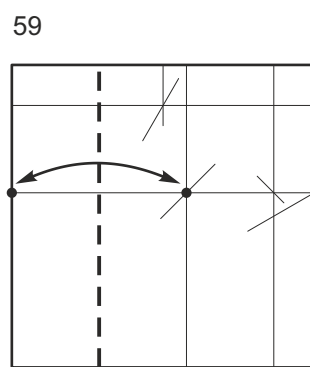
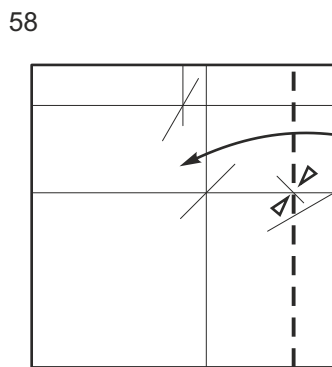
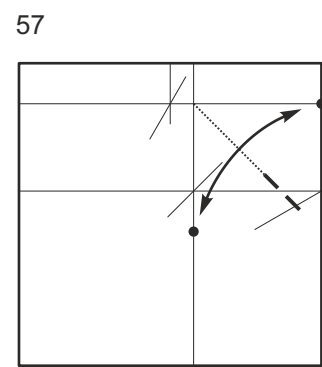
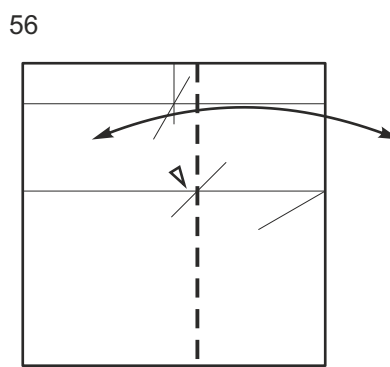
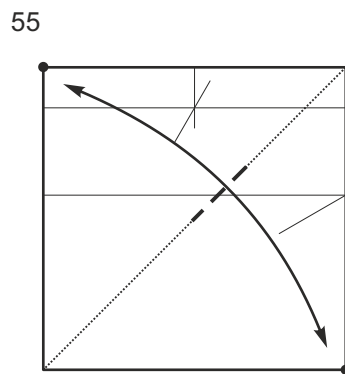
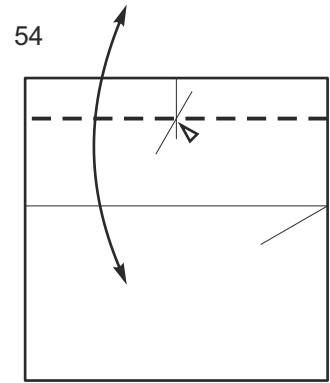
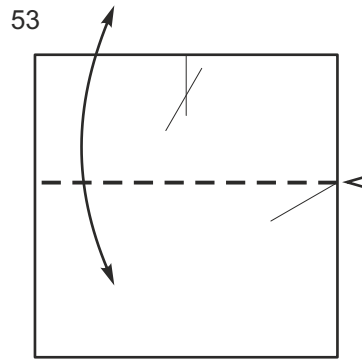
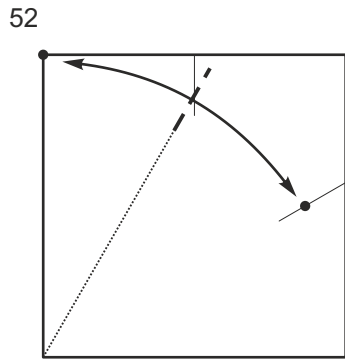
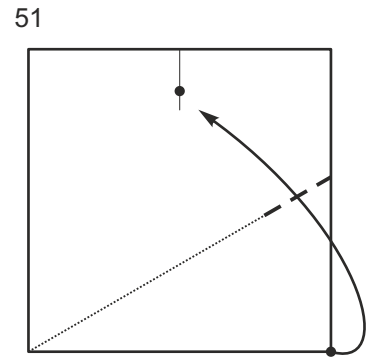
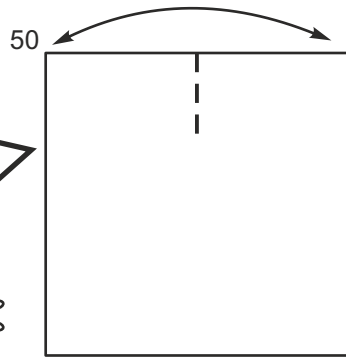
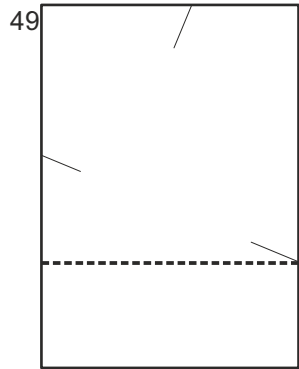

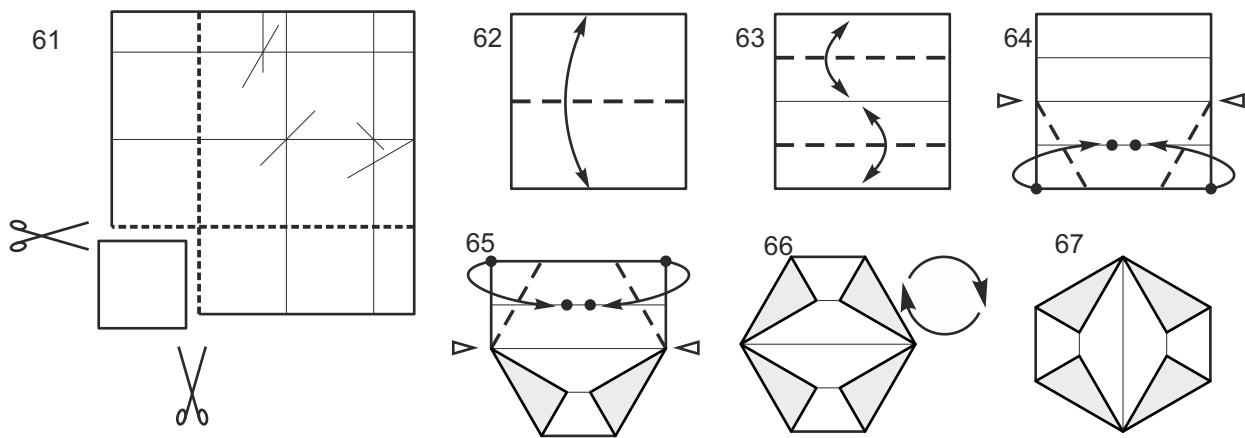

Preparazione delle tessere per la «stellazione» dell'ottaedro (stella Octangula).

Giunto «corto» tipo 2 terminato

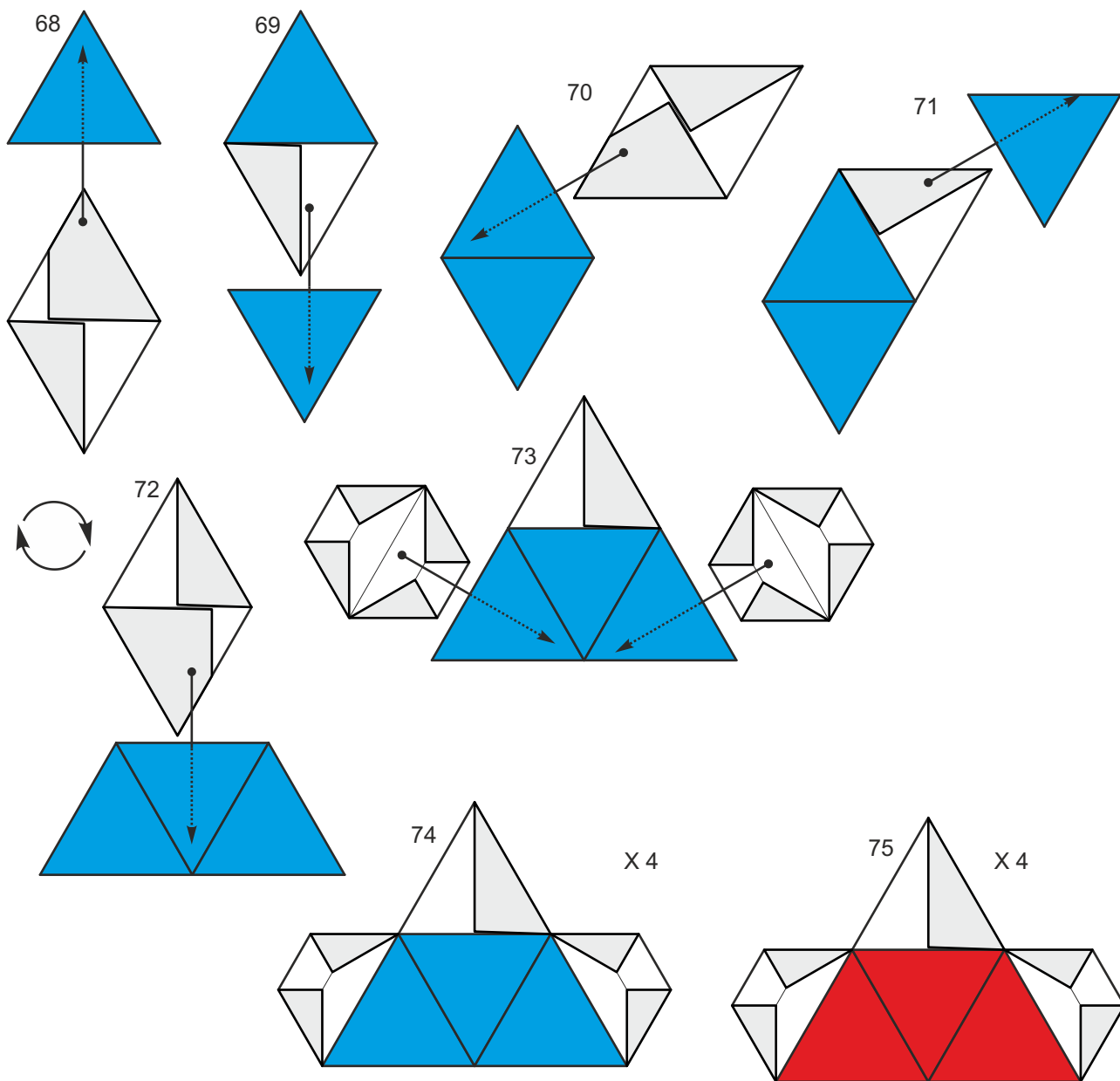

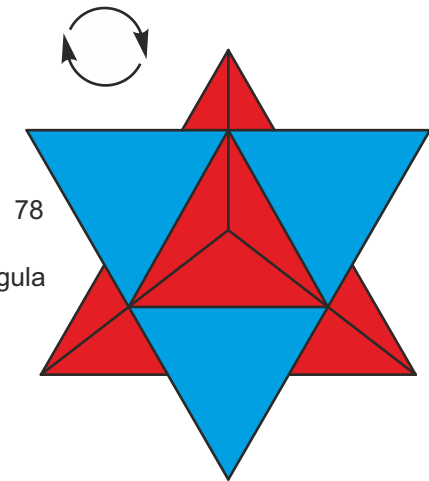
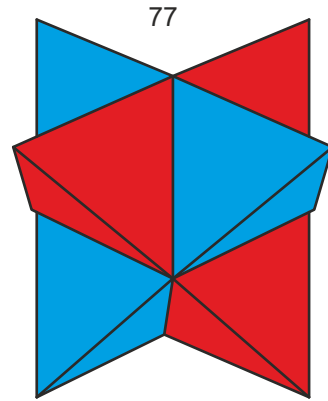
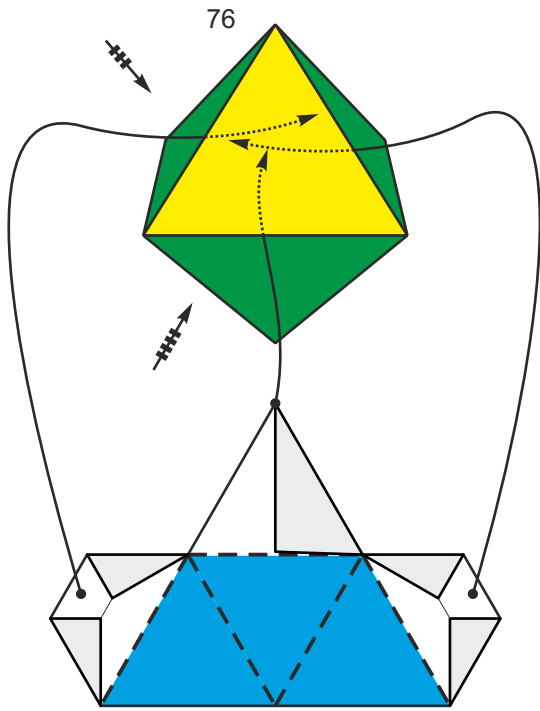

La stella Octangula terminata

Inserto per portare la stella Octangula a cubo

Partire dal n. 5

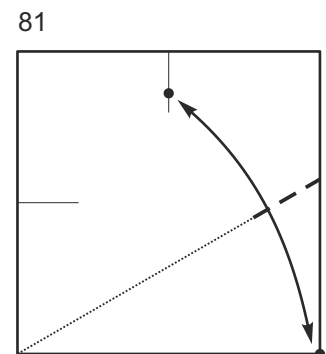
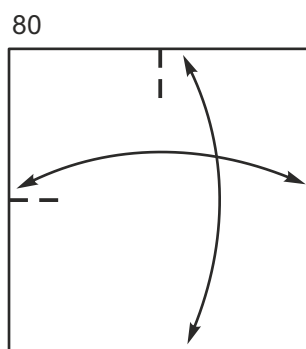
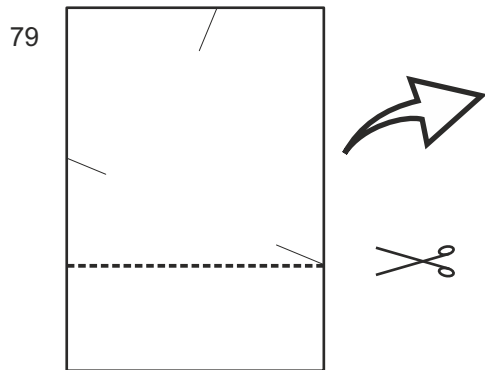

82

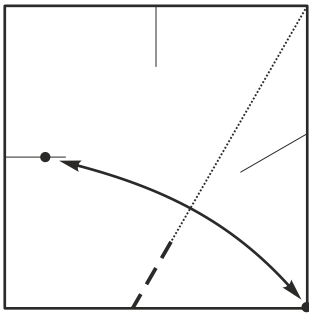

83

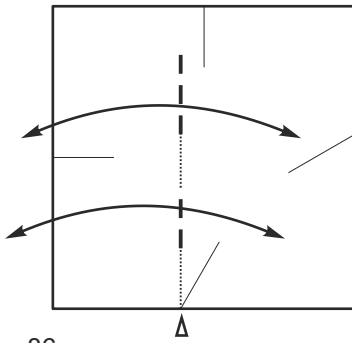

84

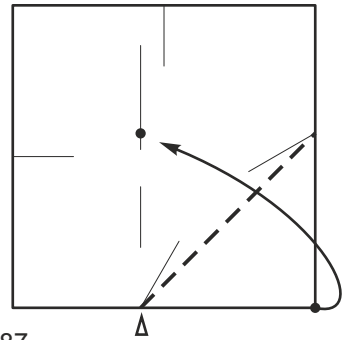

85

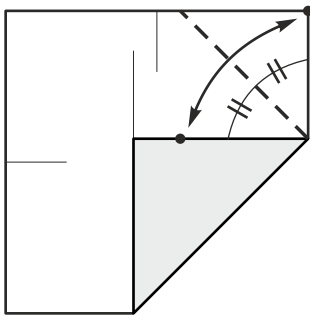

86

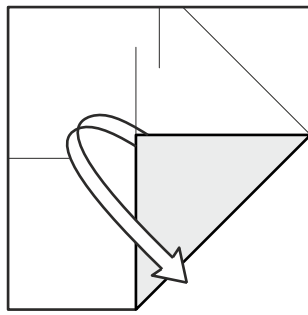

87

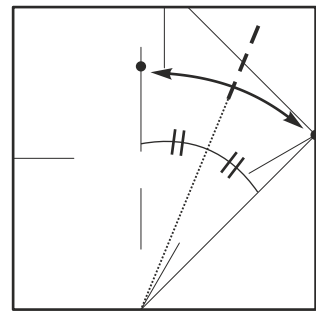

88

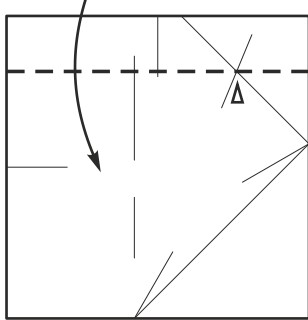

89

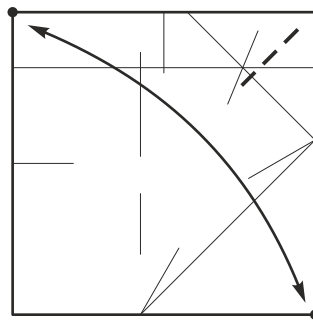

90

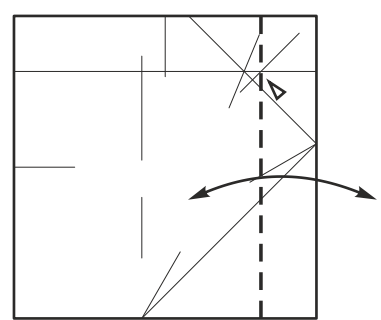

91

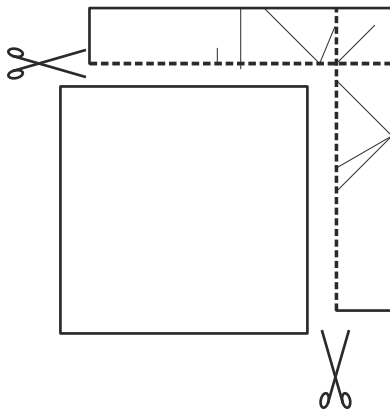

92

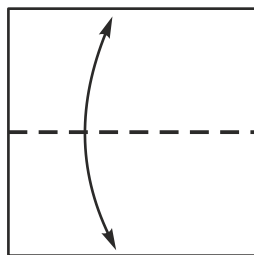

93

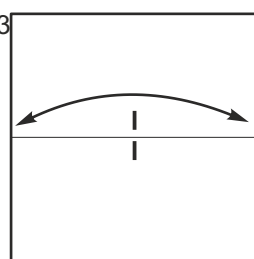

94

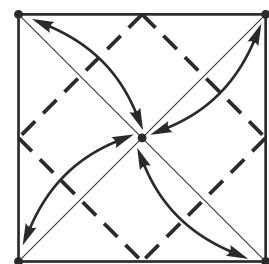

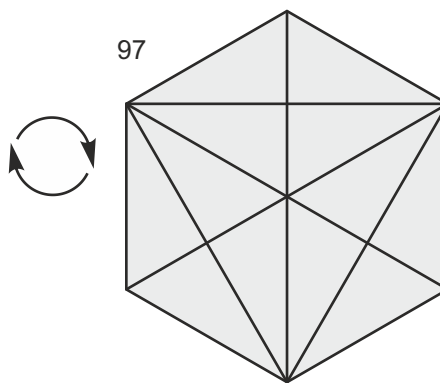
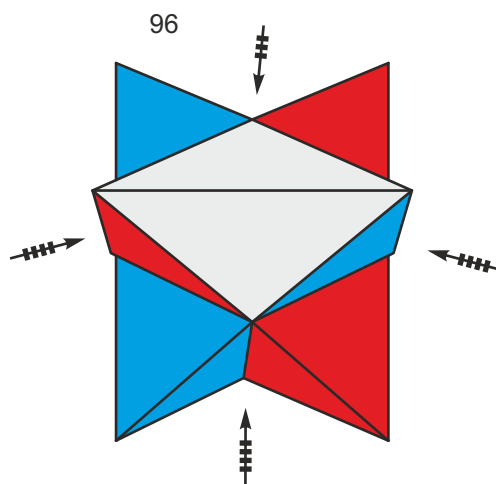
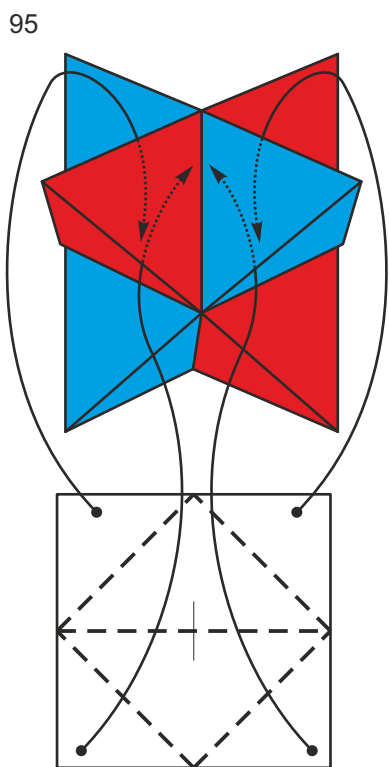

Inserto: SISTEMA ALTERNATIVO (metodo Dima)

Partire dal n. 5

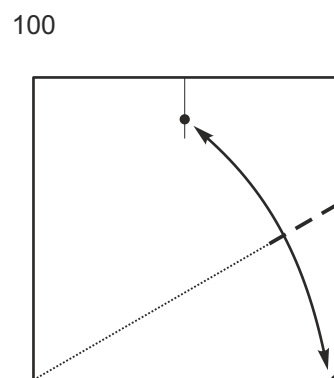
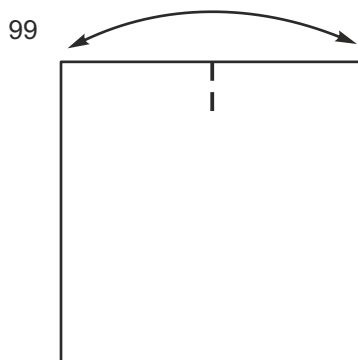
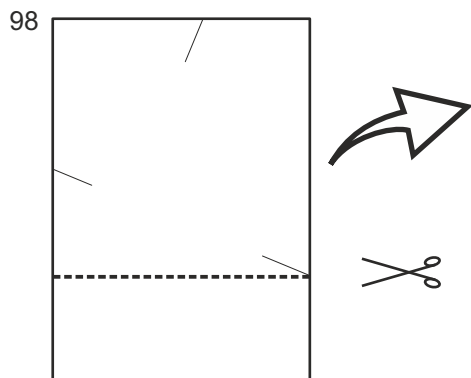

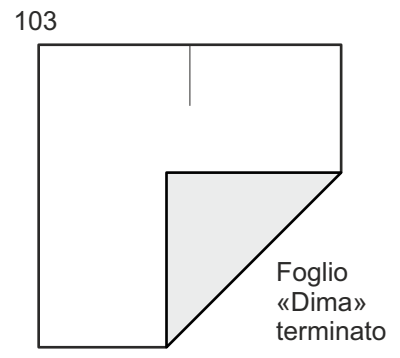
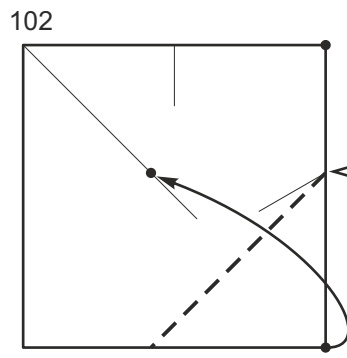
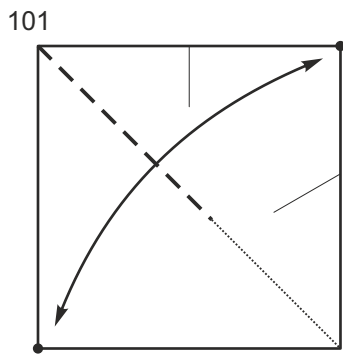

Uso del foglio «Dima»

Partire dal n. 5

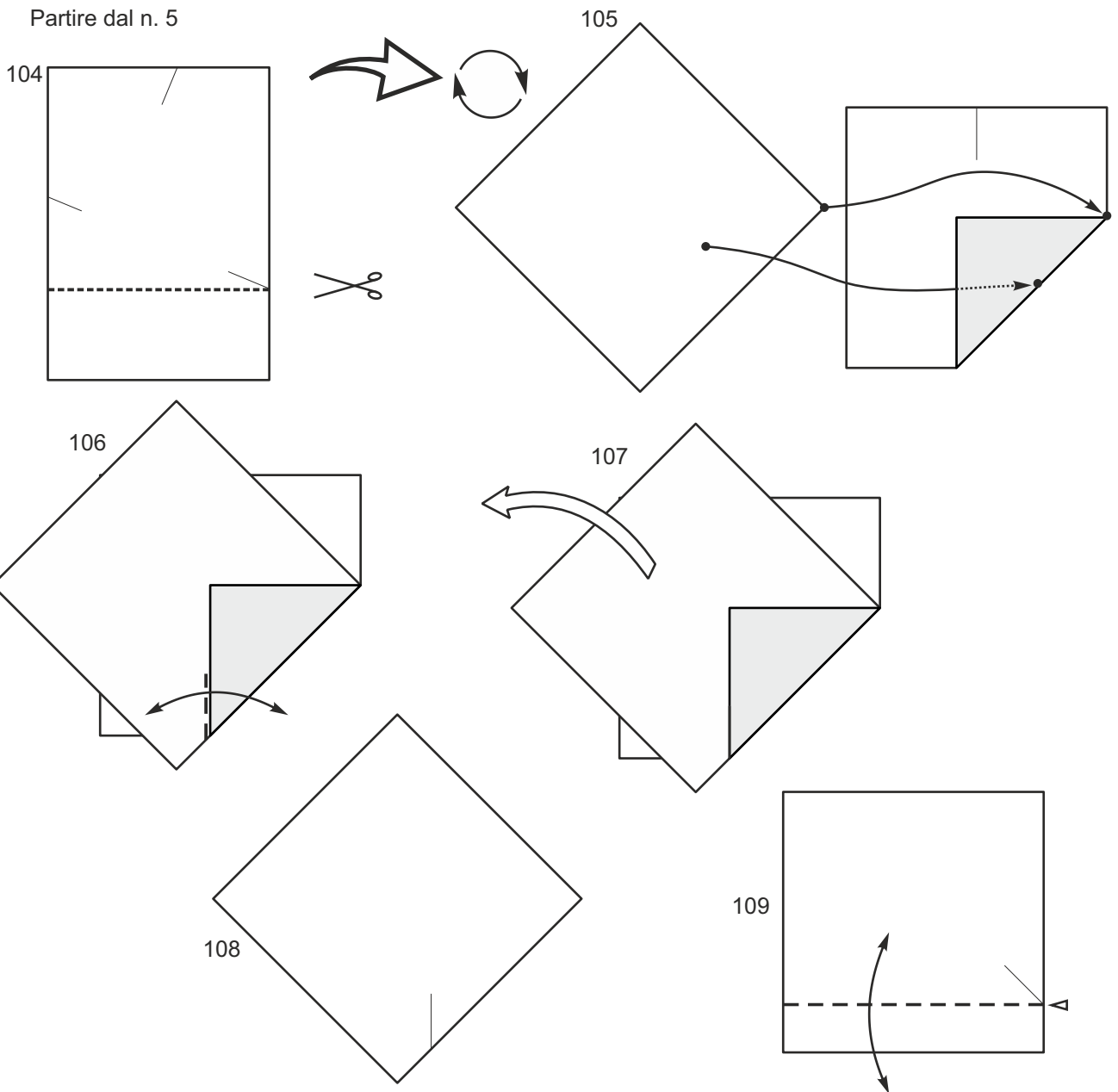

110

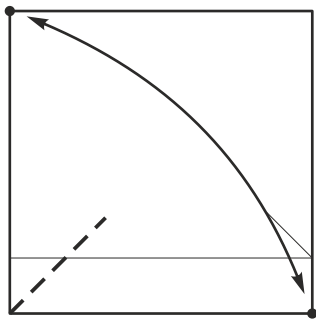

111

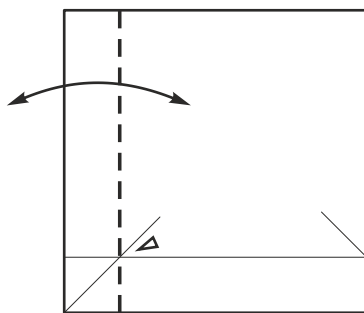

112

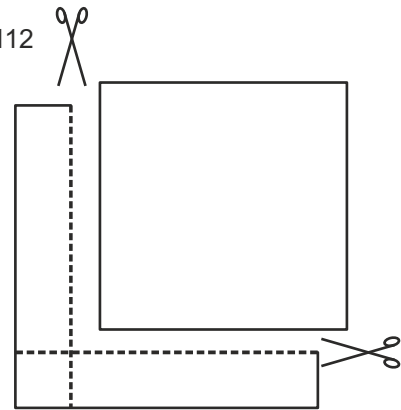

113

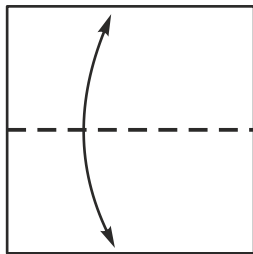

114

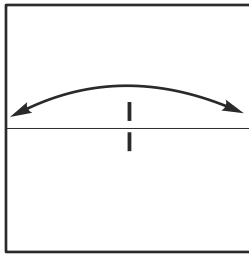

115

