



MASCHERE ORIGAMI 3D

Volume 1



FRANCO PAVARIN

MASCHERE ORIGAMI 3D

Volume 1

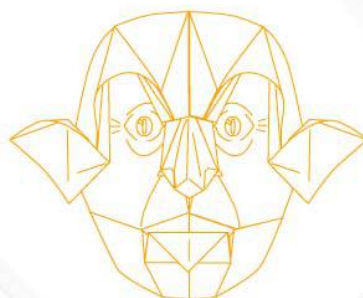
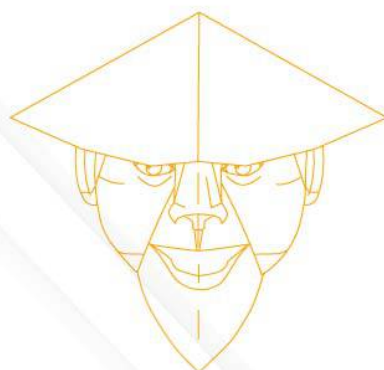
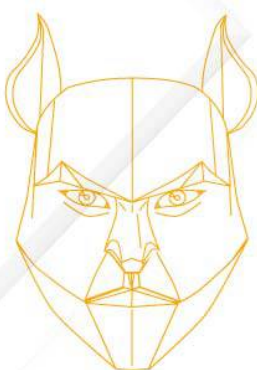
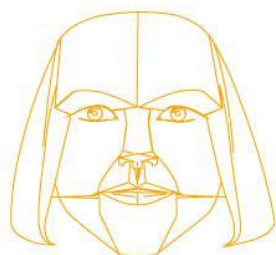
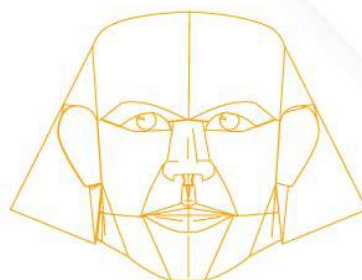
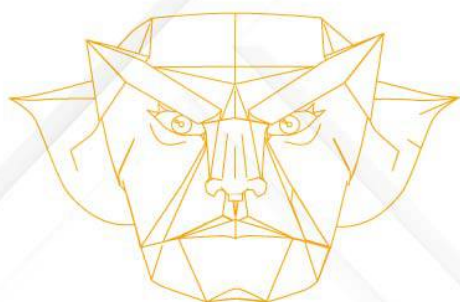

FRANCO PAVARIN

Presentazione

Le maschere di questo volume rappresentano la naturale evoluzione di quelle di un mio vecchio libro del 1988, dalle quali però differiscono per due motivi: sono tridimensionali, quindi non possono essere animate, cioè non muovono la bocca; sono complicate, indirizzate ad origamisti esperti e destinate quindi ad essere pubblicate solamente nel WEB.

Sono adatte per un uso espositivo ma possono anche essere indossate, previo ritaglio degli occhi e del fondo della bocca.

Ho raccolto in fondo al volume i disegni in scala reale degli occhi indicati per migliorare l'espressività delle maschere e che possono essere fotocopiati, ritagliati e incollati.

In volumi successivi presenterò maschere ancora più elaborate ed accessori di vario genere, che si fissano con un incastro nella piega della fronte, per personalizzarle a piacere.

Dicembre 2014

Franco Pavarin

Tecniche costruttive

Per la realizzazione delle maschere sono utili alcuni semplici attrezzi, che potrete anche costruire da soli:

- Righelli affilati di varie misure con un'estremità appuntita.
- Strisce di latta o alluminio, per realizzare pieghe curve.
- Tubicino per realizzare pieghe morbide, quali quelle del naso e delle guance.
- Pinzette con punta tonda per eseguire pieghe curve.
- Mollette per bloccare una piega.
- Riga lunga per eseguire le pieghe iniziali su grandi fogli.

Le maschere si costruiscono con cartoncino monocoloro che si irrigidisce inumidendone con un pennellino gli spigoli.

Eventualmente è possibile irrigidirle ulteriormente con vernice trasparente tipo flatting e rifinirle con vernice a spruzzo.



















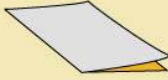









Per poterle indossare, si fissa con punti metallici un elastico e si ritagliano occhi e fondo della bocca.

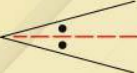

Indice

Presentazione	2
Tecniche costruttive	2
Simbologia	4
Pieghe rovesce	5
Licantropus	6
Tutankamon	24
Spook	35
Jedi Yoda	46
Caronte	54
Skirr	65
Leonardo	74
Merlino	85
Meo Lin	94
Valentina	103
Jenny	115

Simbologia origami

	Indicazione	Risultato 3D
 Piegata a valle (piegata bassa)		
 Piegata a monte (piegata alta)		
 Piegata ruotando verso l'alto		
 Piegata ruotando verso il basso		
 Ruotate, piegate e riportate alla posizione iniziale		
 Ribaltate sull'asse verticale		
 Ribaltate sull'asse orizzontale		
 Ruotate di 180°		
 Piegata bisettrice a valle		
	 	

Realizzazione delle pieghe rovesce

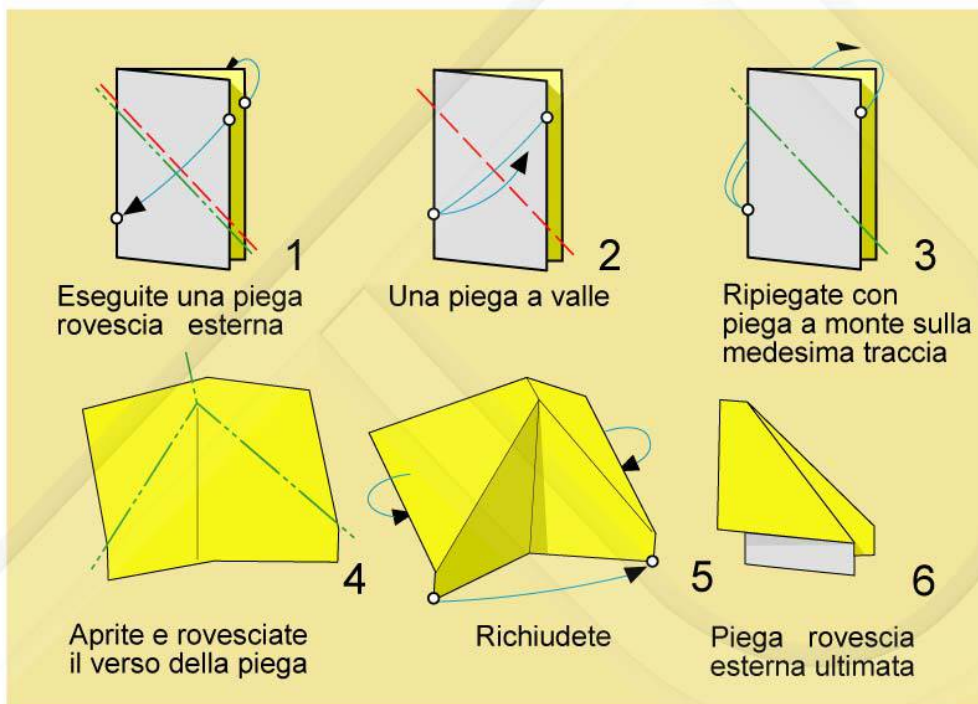
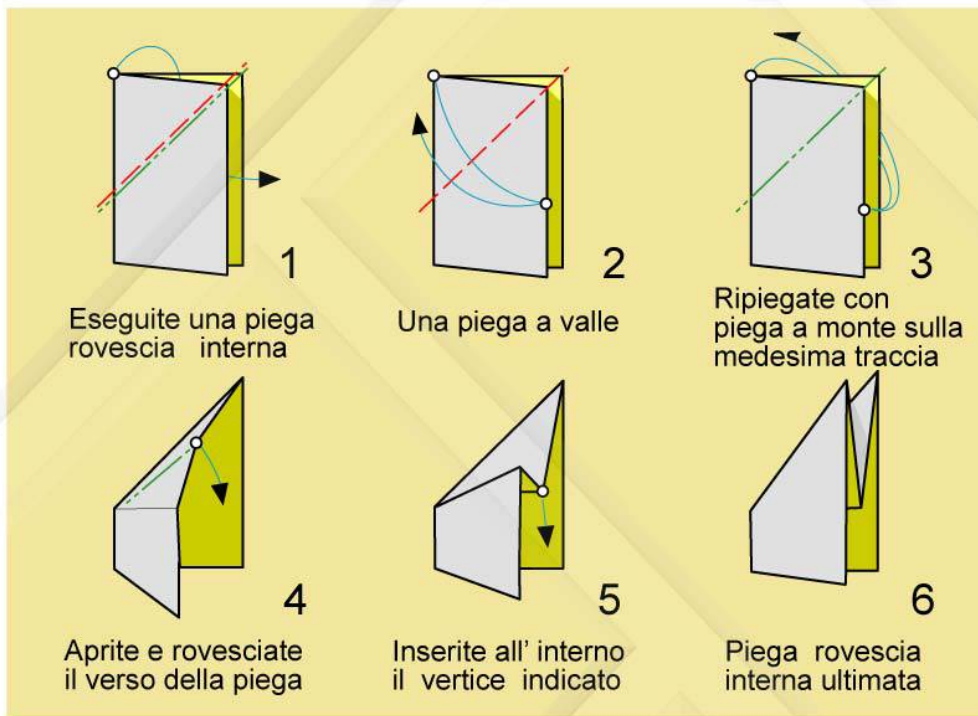

LICANTROPUS



Questa maschera raffigura l'uomo lupo per il suo aspetto bestiale e l'espressione di malvagità brutta.

Partite da un foglio di cartoncino quadrato di 42 cm di lato

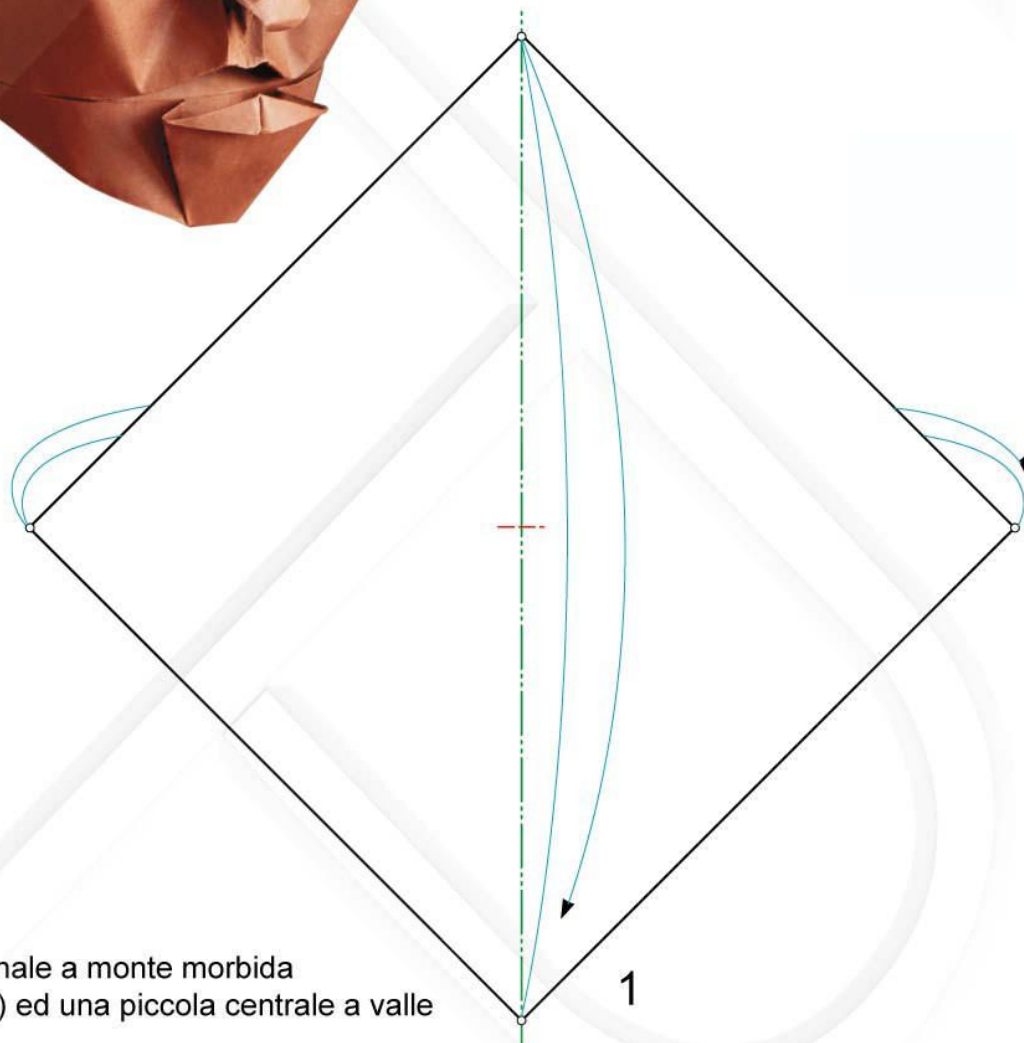

1 piega diagonale a monte morbida (non pressata) ed una piccola centrale a valle

6

1

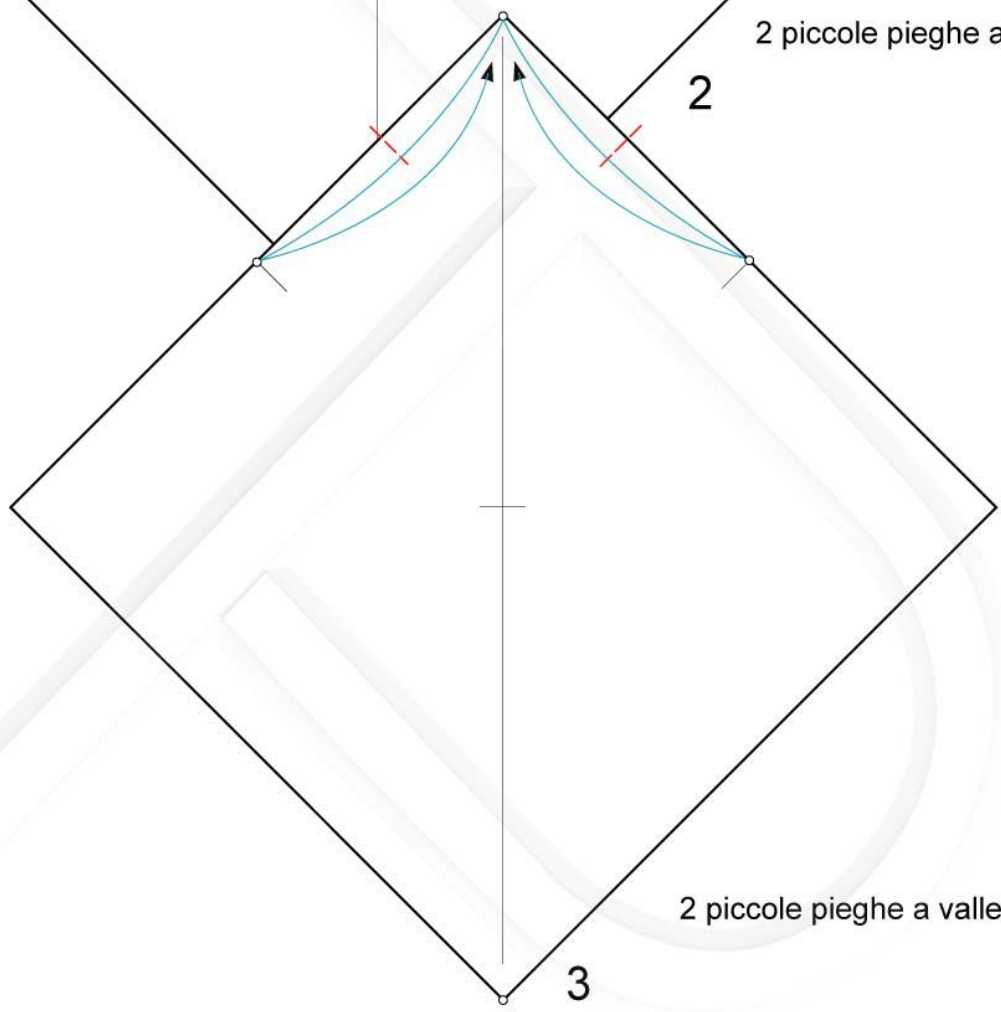
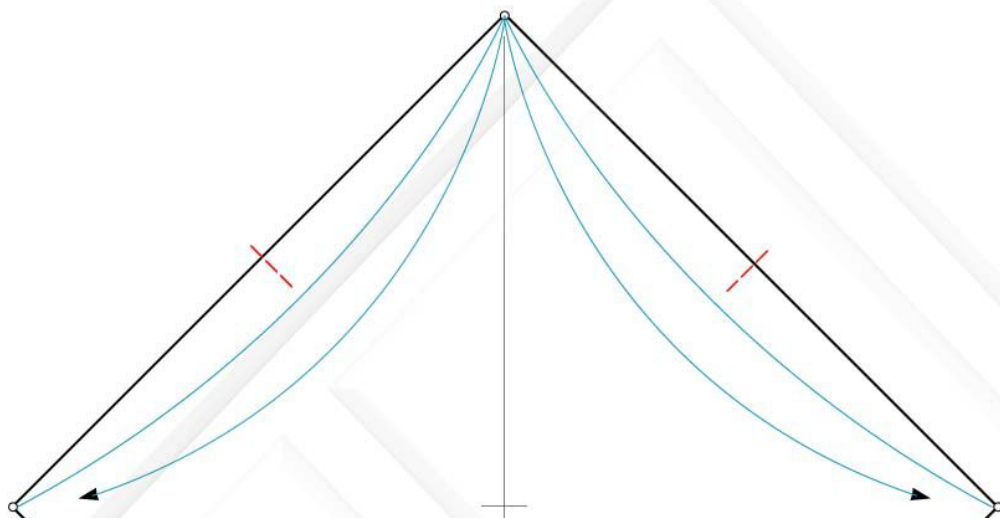

2 piccole pieghe a valle

2

2 piccole pieghe a valle

3

7

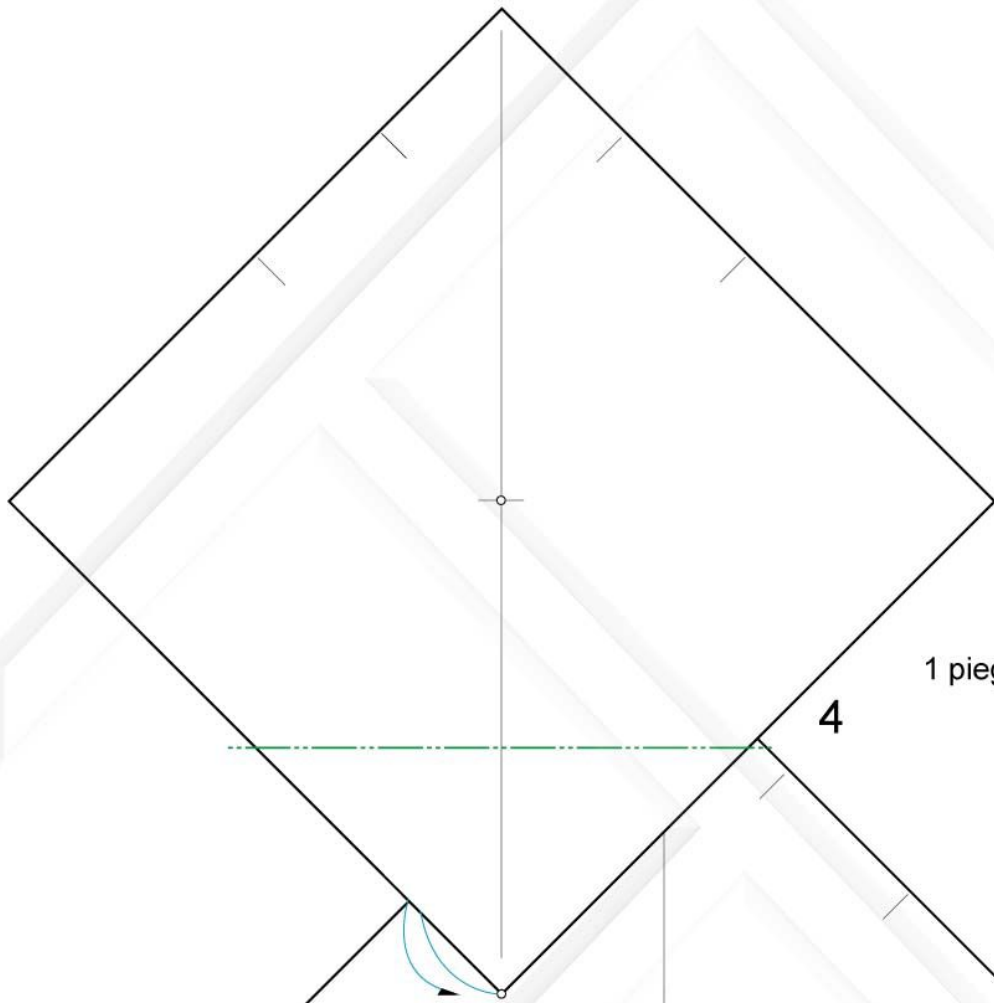

1 piega a monte

4

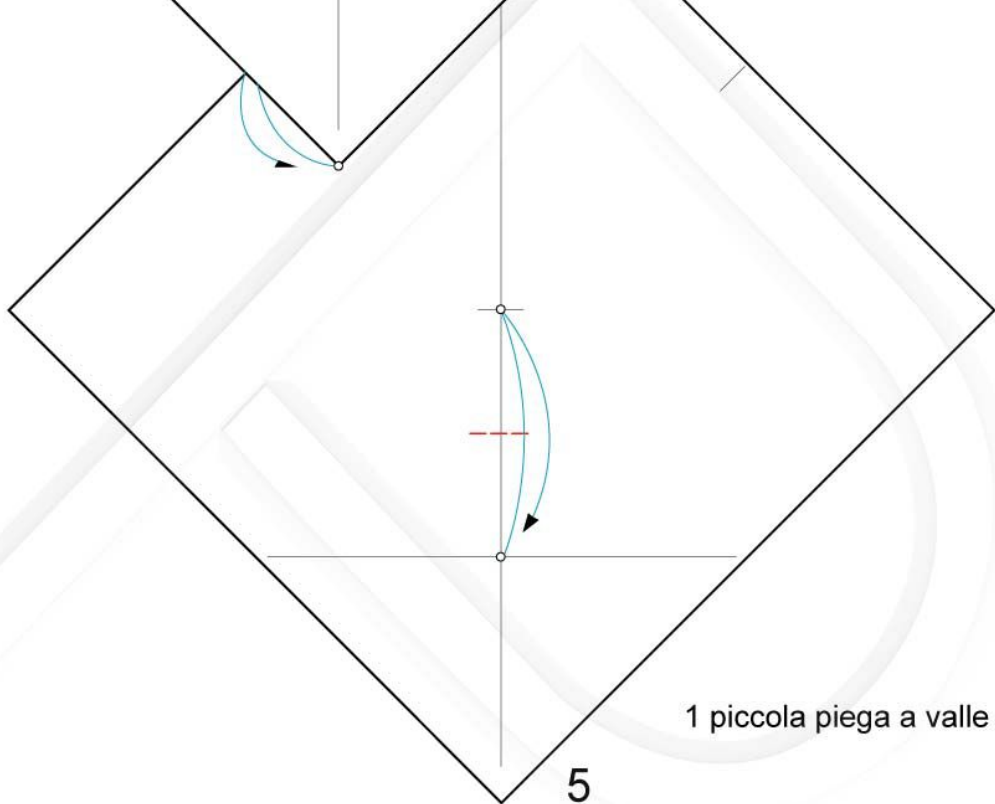

1 piccola piega a valle

5

8

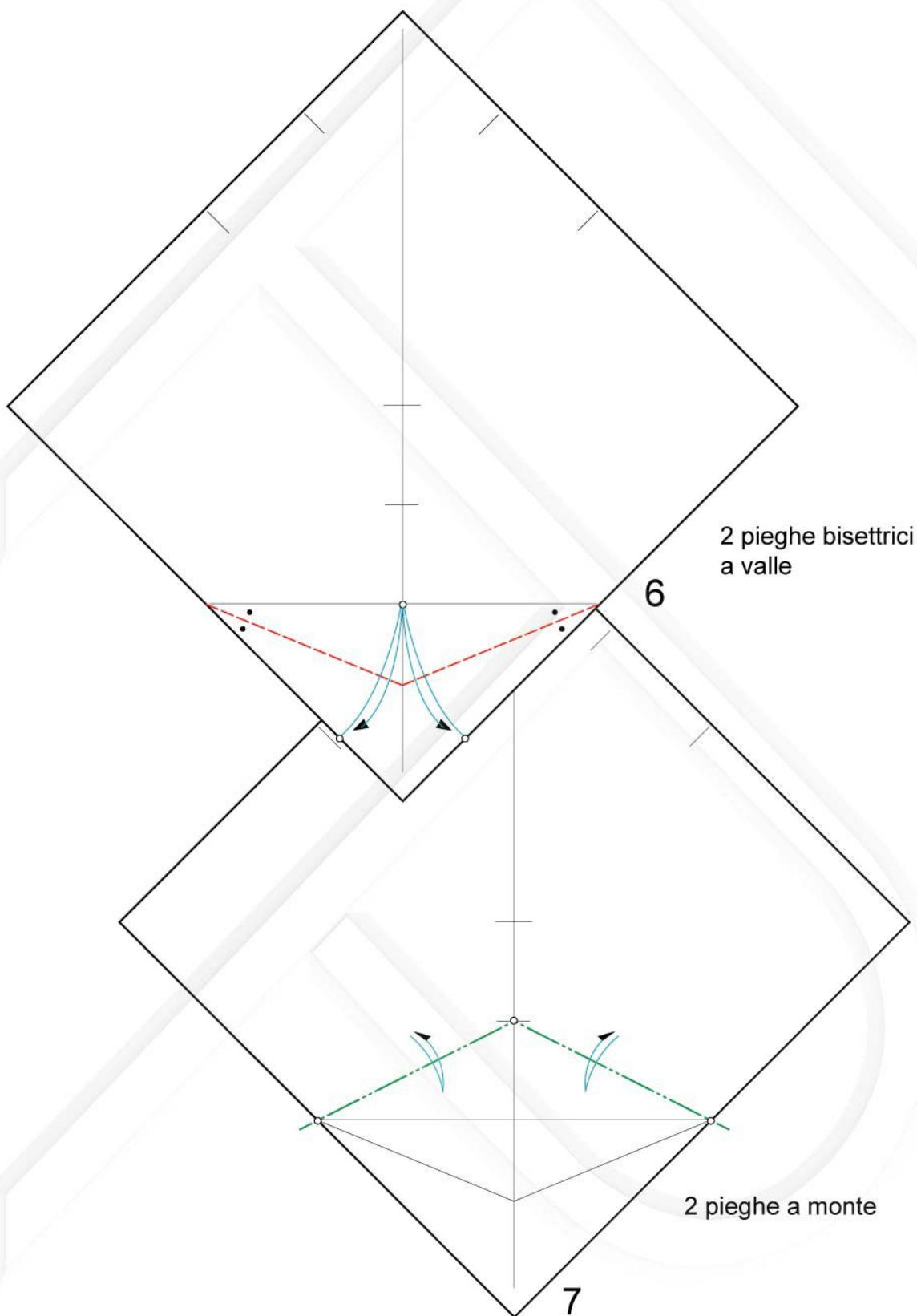

2 pieghe bisettrici
a valle

6

2 pieghe a monte

7

9

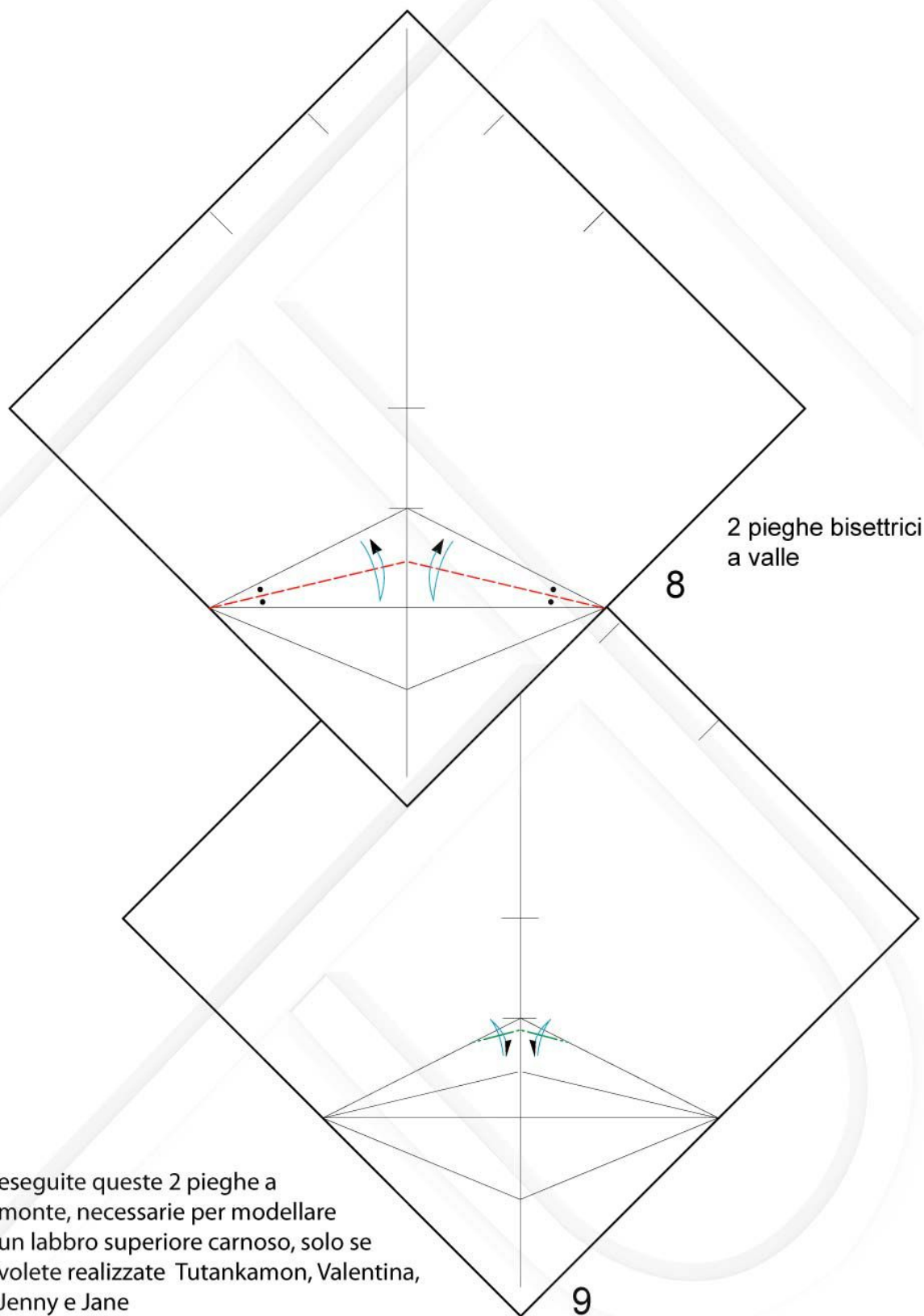

eseguite queste 2 pieghe a monte, necessarie per modellare un labbro superiore carnoso, solo se volete realizzare Tutankamon, Valentina, Jenny e Jane

10

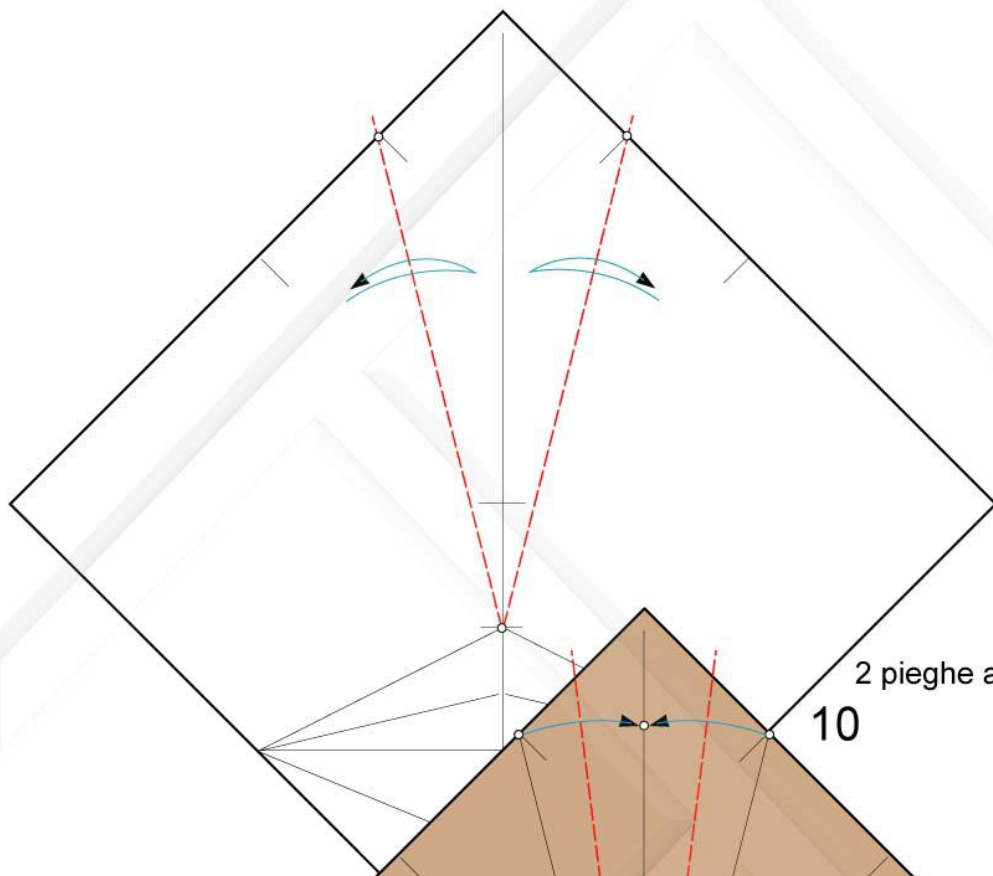

2 pieghe a valle e ribaltate
10

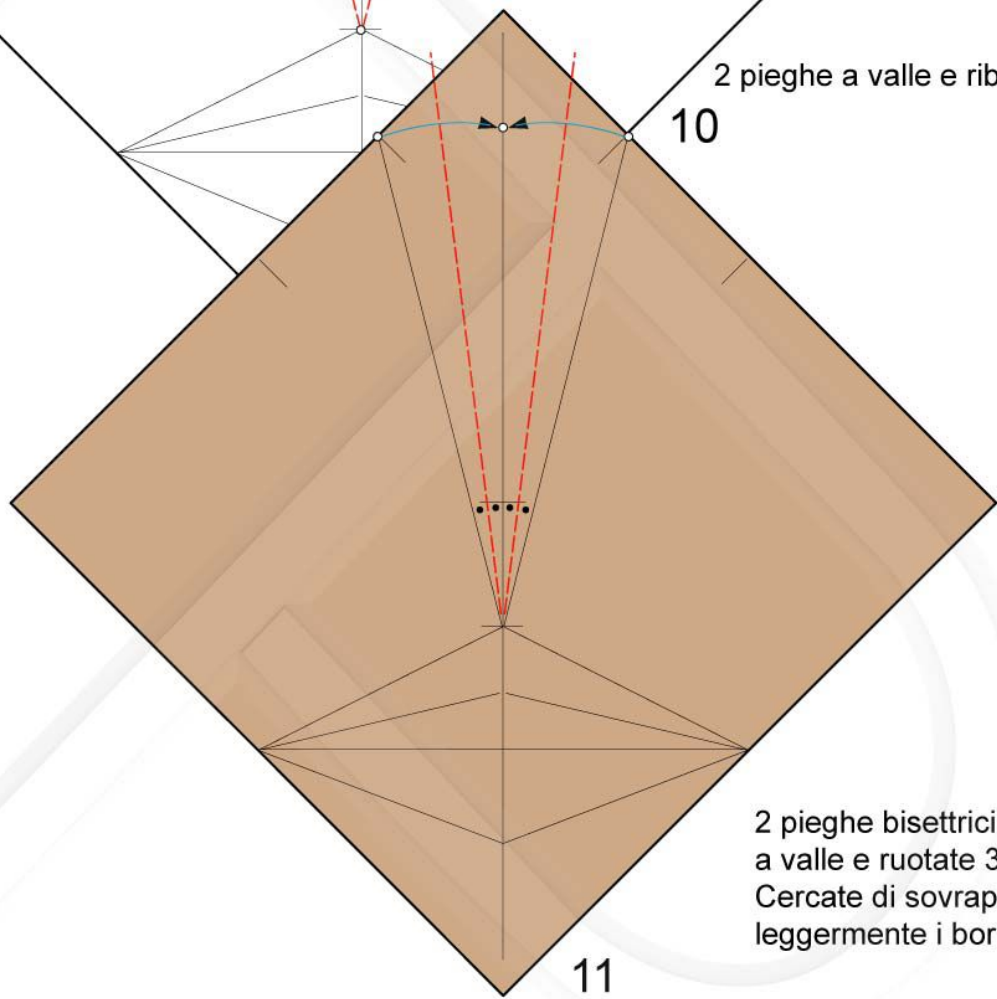

2 pieghe bisettrici
a valle e ruotate 3D.
Cercate di sovrapporre
leggermente i bordi

11

11

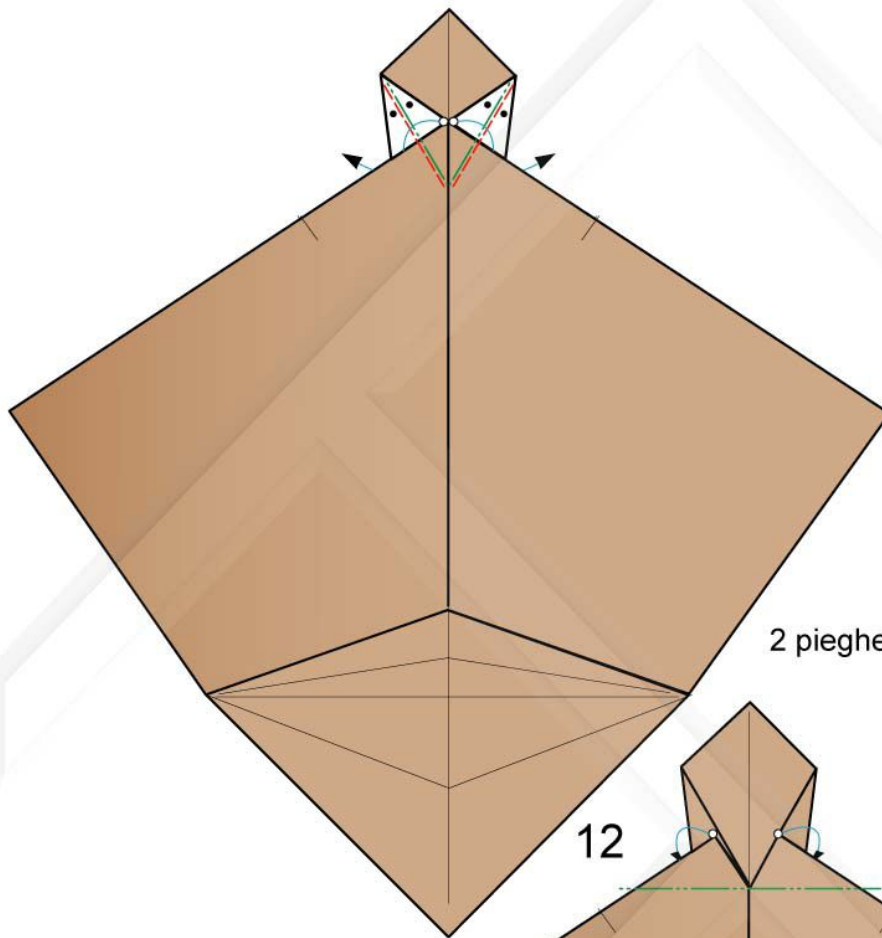

2 pieghe rovesce interne

12

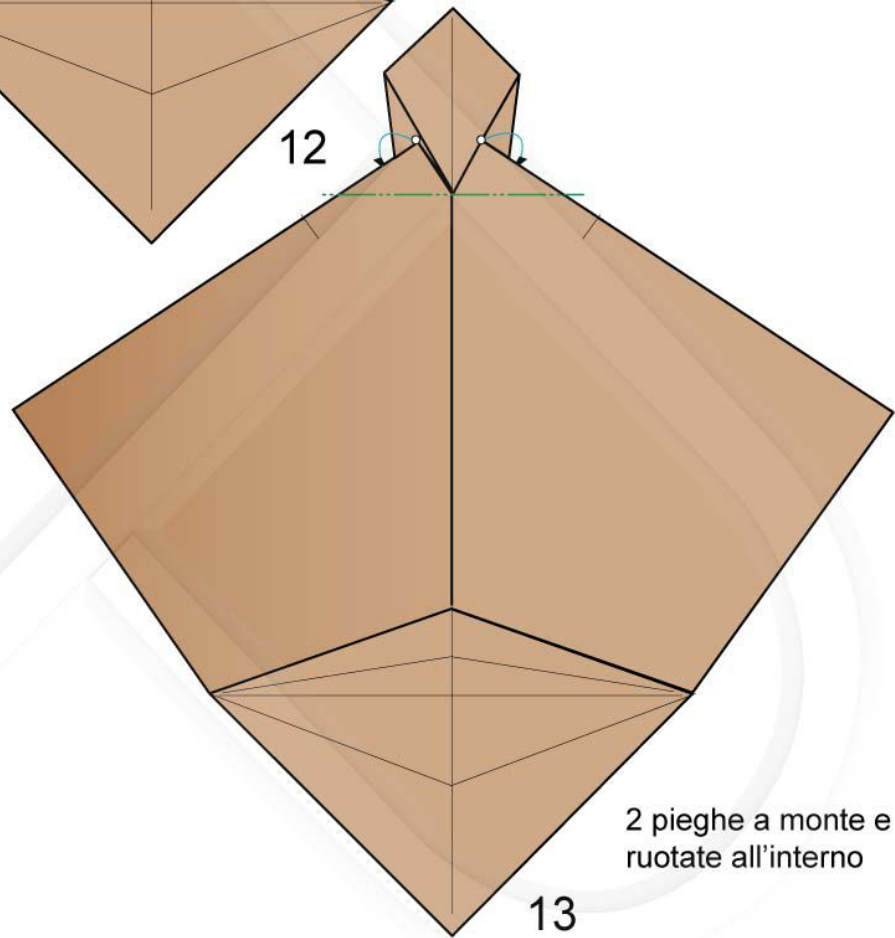

2 pieghe a monte e ruotate all'interno

13

12

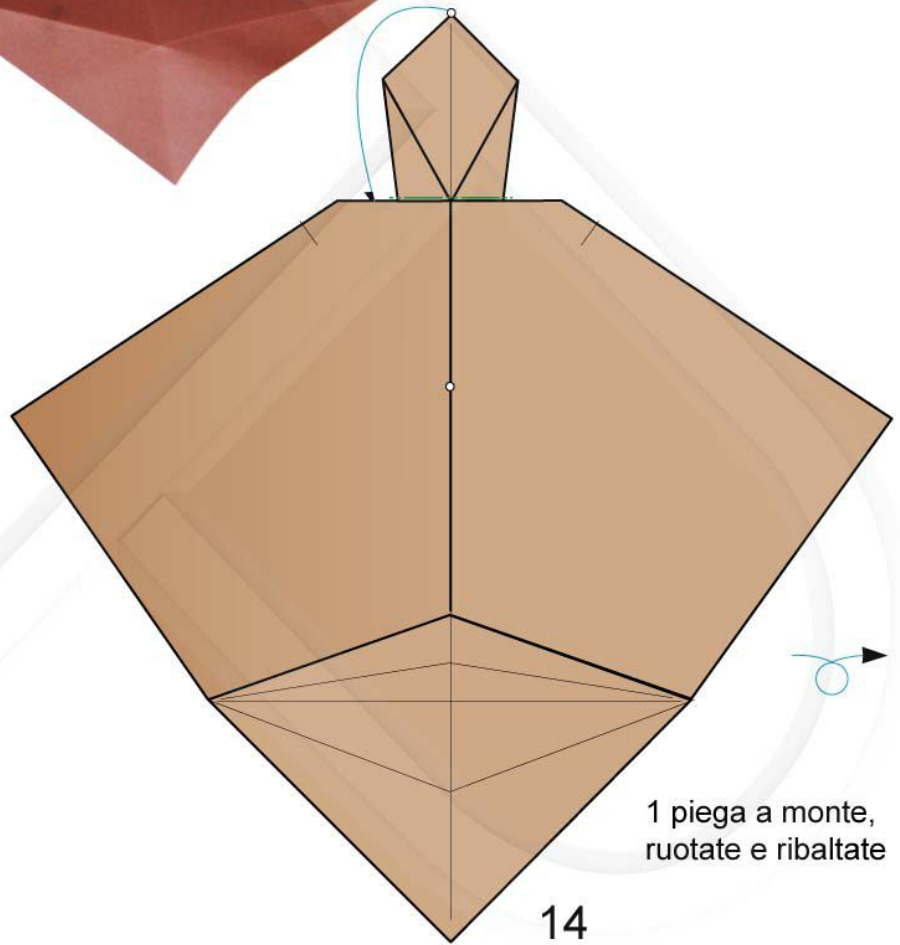
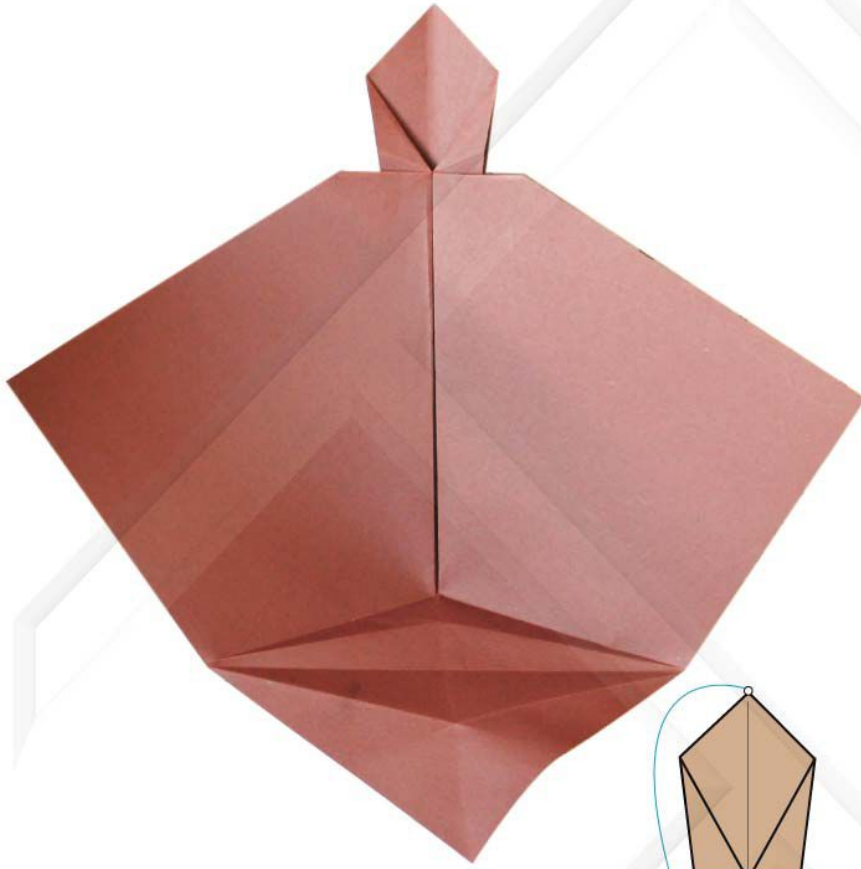

1 piega a monte,
ruotate e ribaltate

14

13

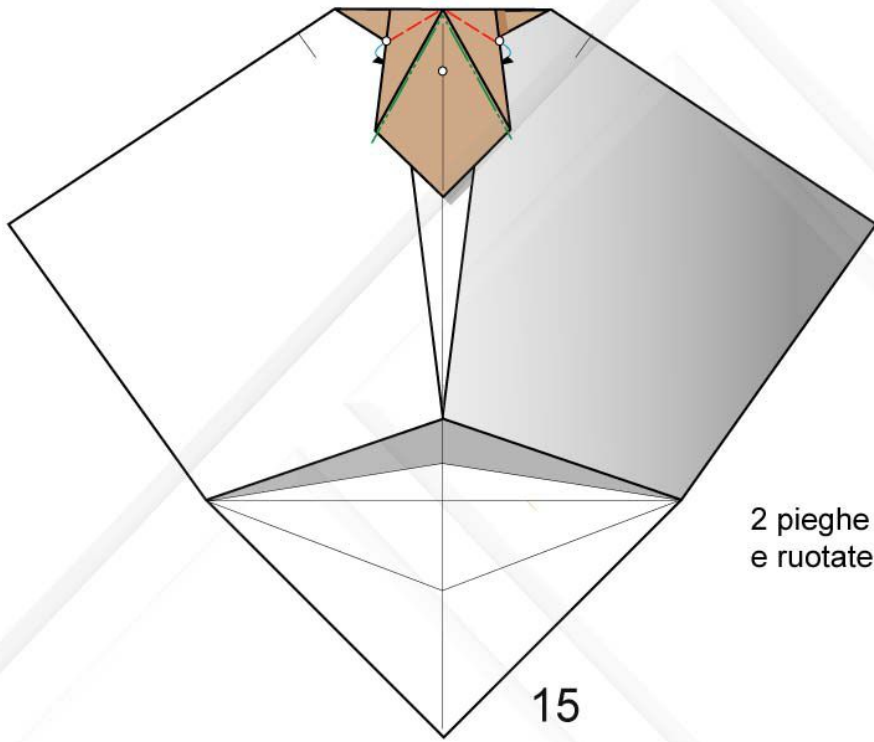

2 pieghe a valle, 2 a monte
e ruotate all'interno

15



14

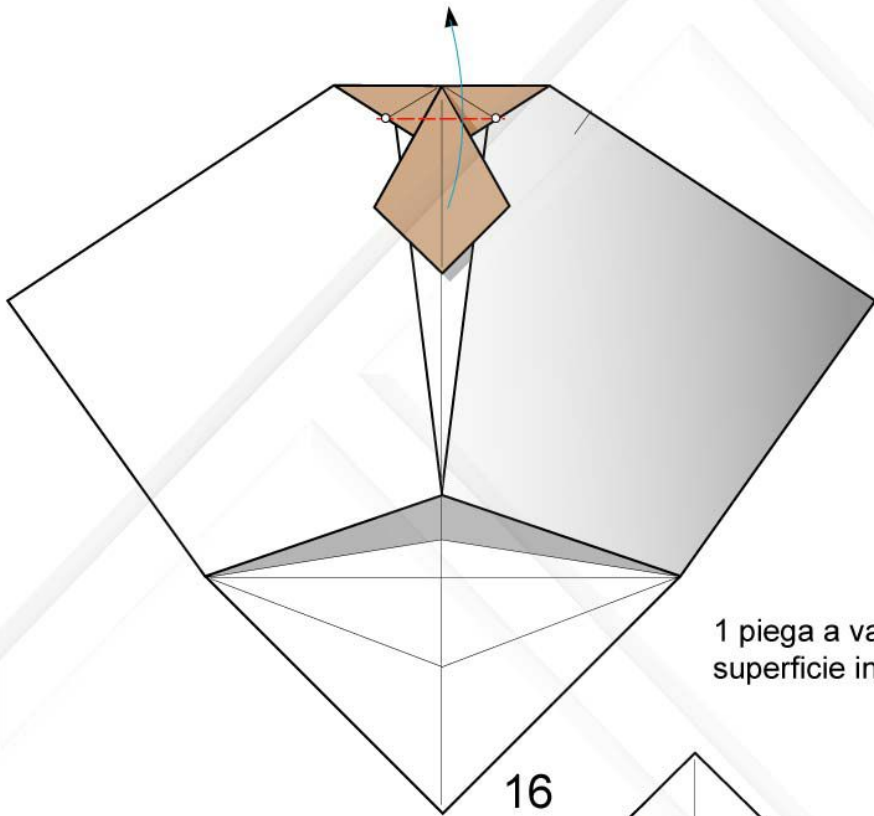

1 piega a valle solo sulla superficie in vista e ruotate

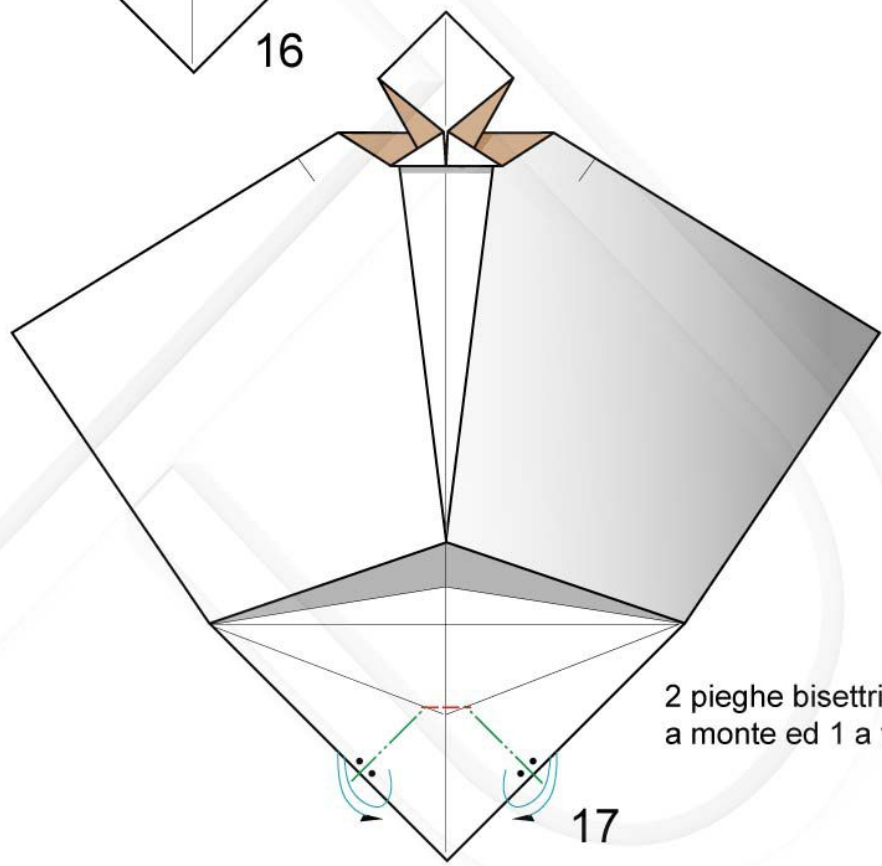

2 pieghe bisettrici a monte ed 1 a valle

15

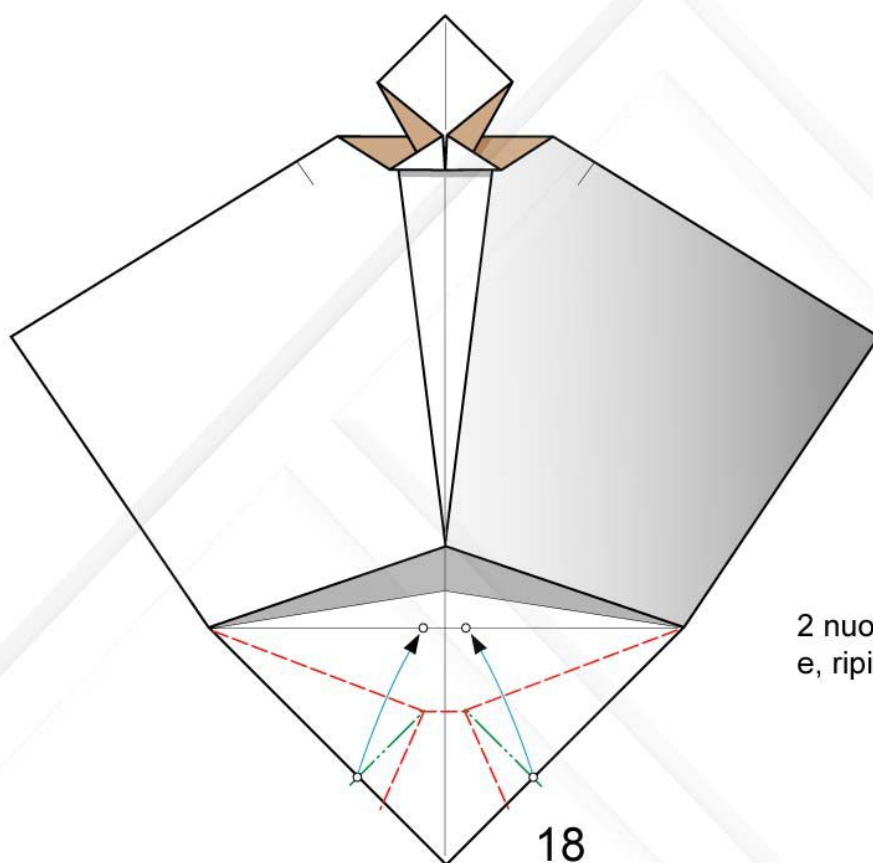

2 nuove pieghe a valle
e, ripiegando, ruotate

18



16

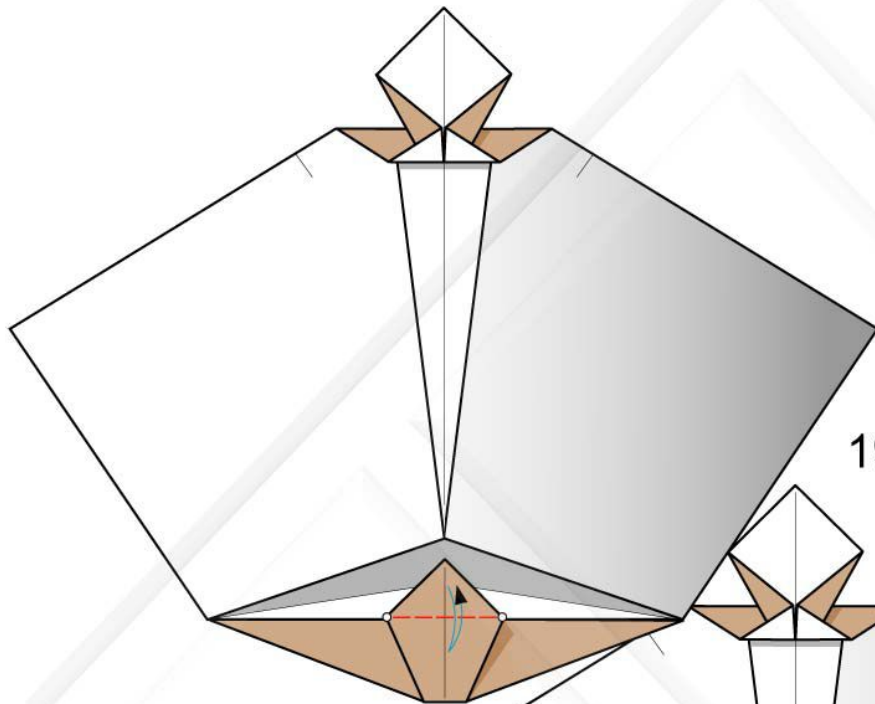

19 1 piega a valle

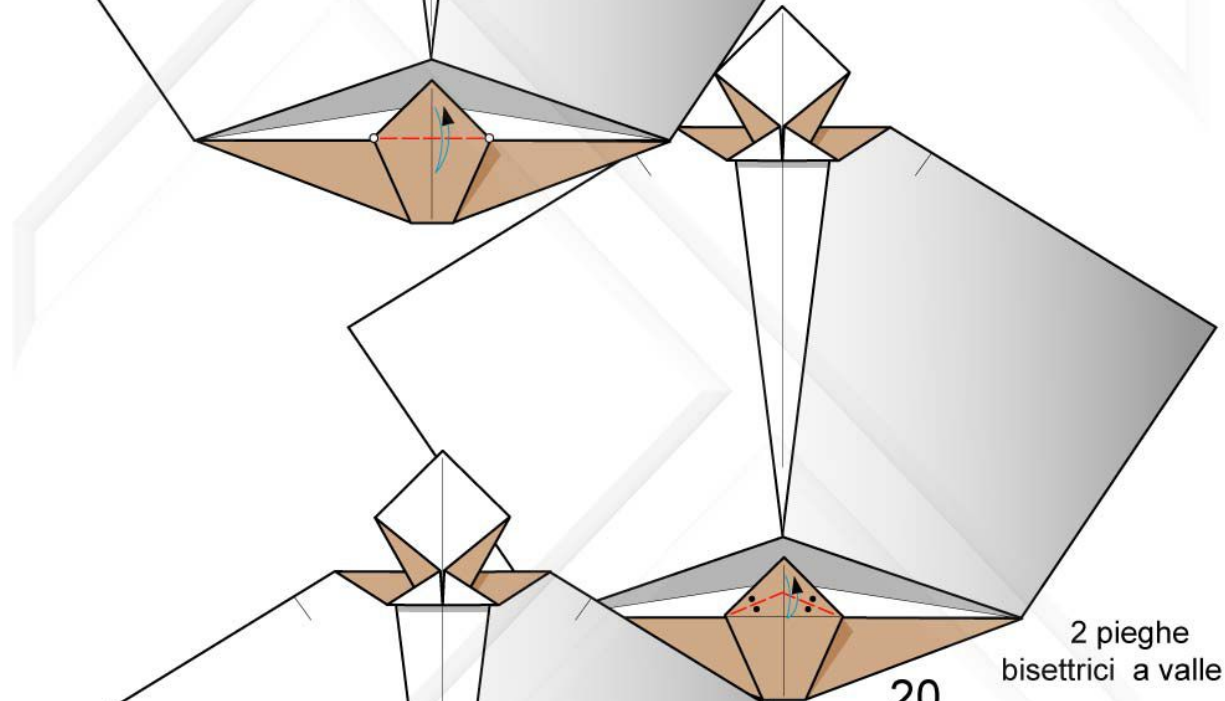

20 2 pieghe bisettrici a valle

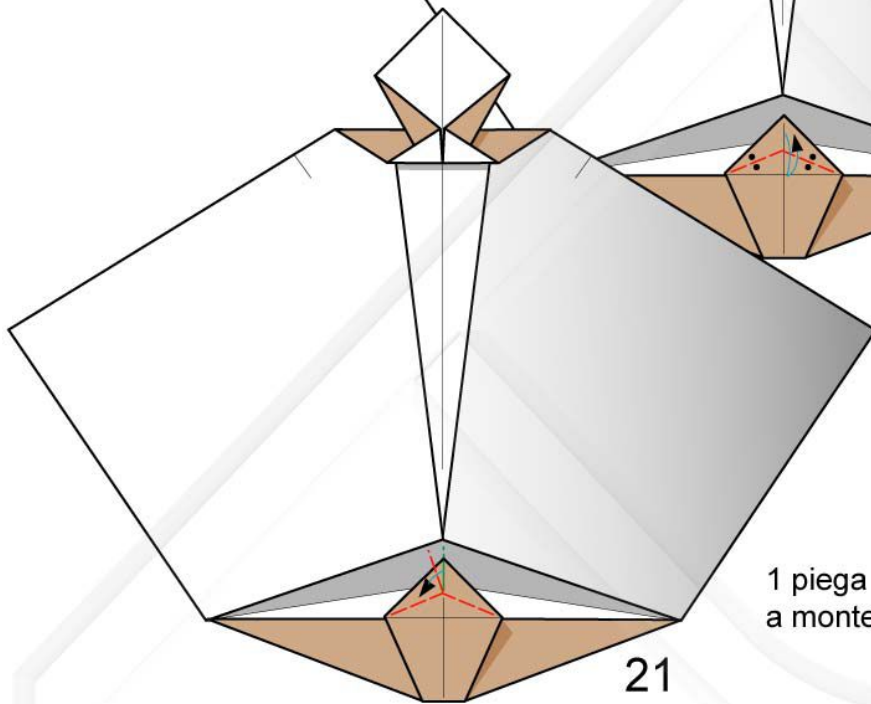

21 1 piega a valle ed 1 a monte e ruotate 3D

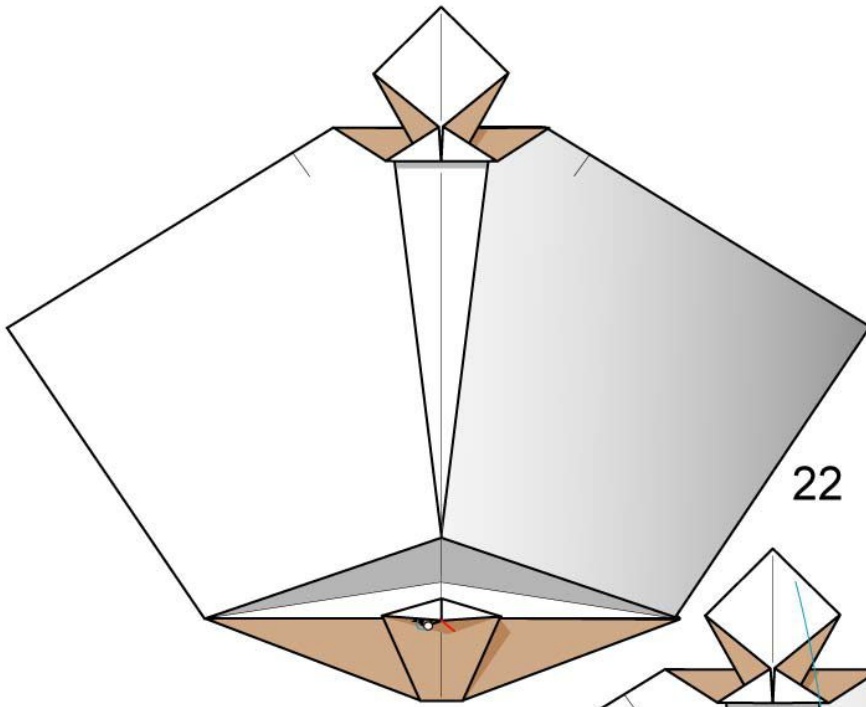

mediante 1 piega a valle
ruotate il vertice inferiore
bloccando il labbro

22

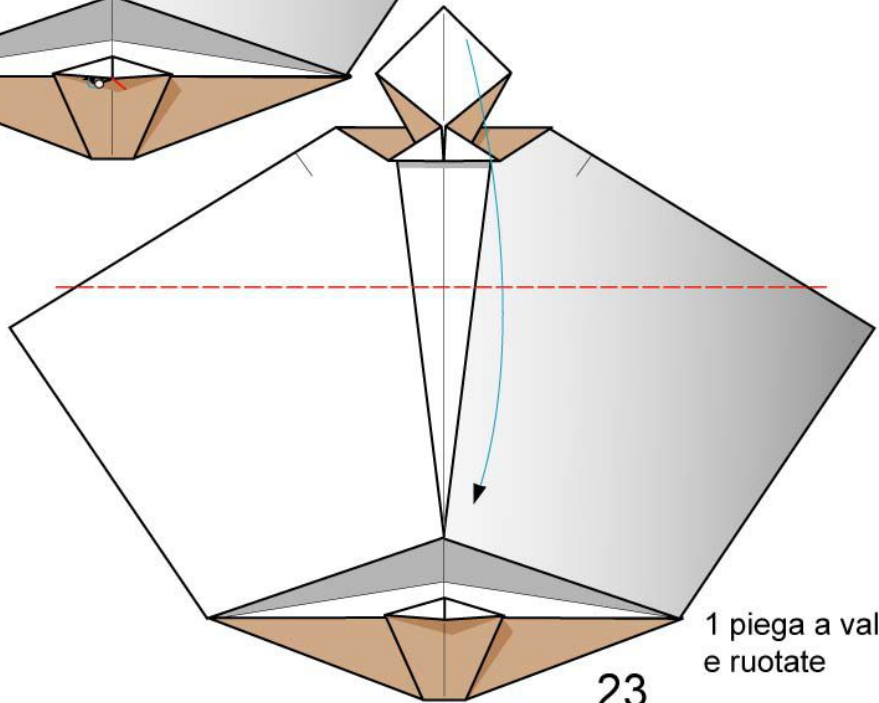

1 piega a valle
e ruotate

23

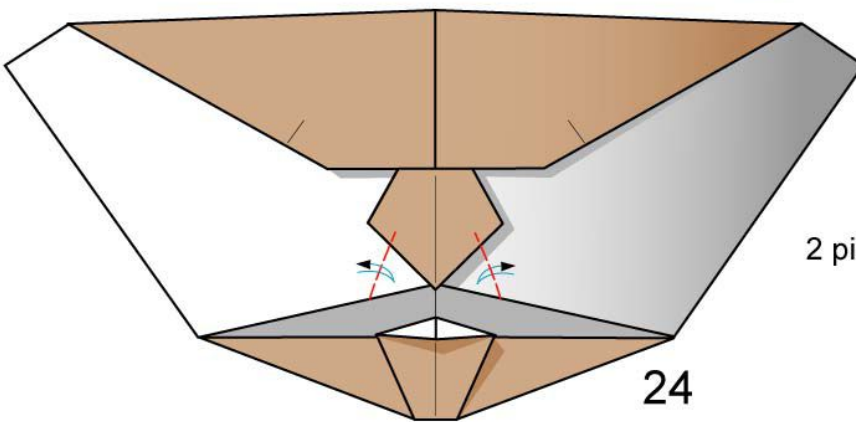

2 pieghe a valle

24

18

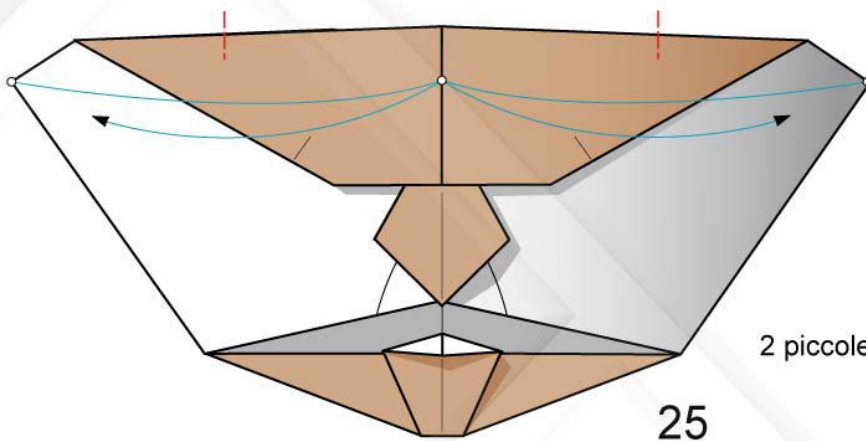
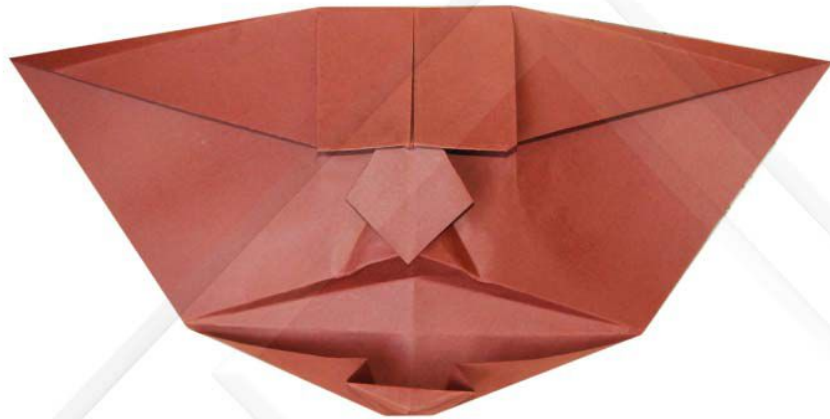

2 piccole pieghe a valle

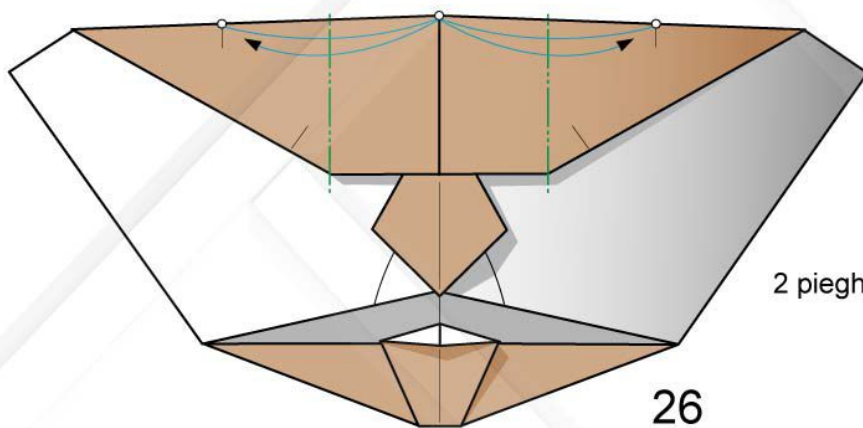

2 pieghe a monte

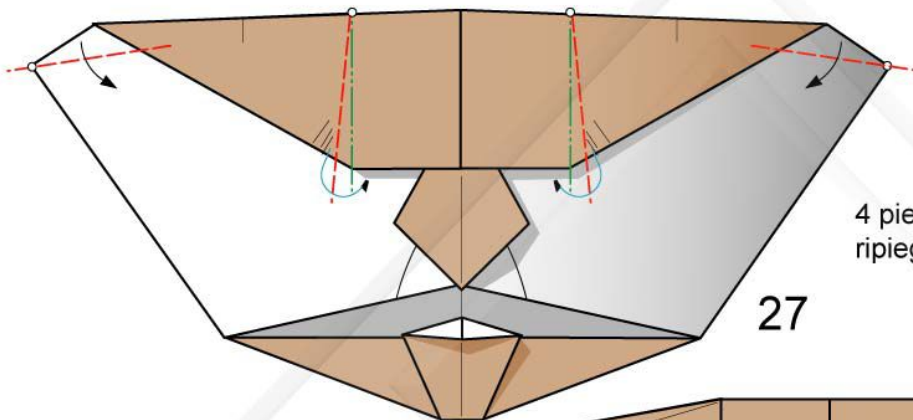

4 pieghe a valle e ruotate
ripiegando a monte

27

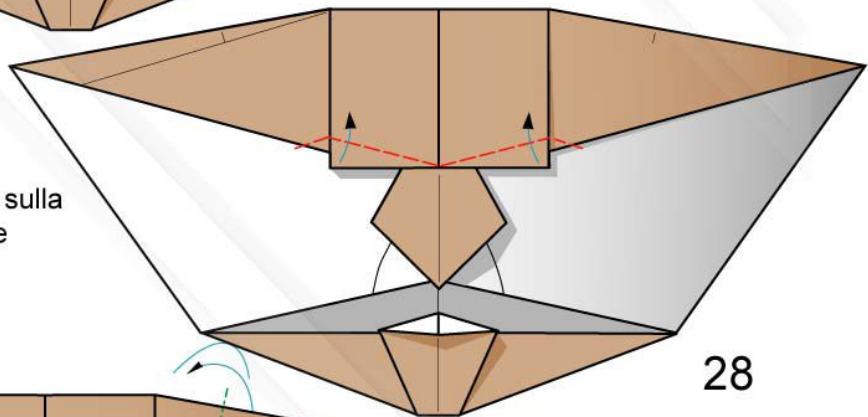

4 pieghe a valle solo sulla
sup. in vista e ruotate

28

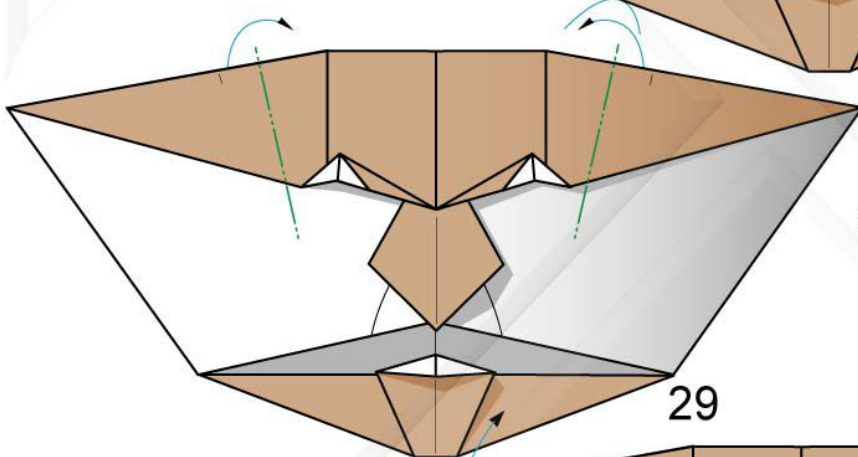

2 pieghe a monte

29

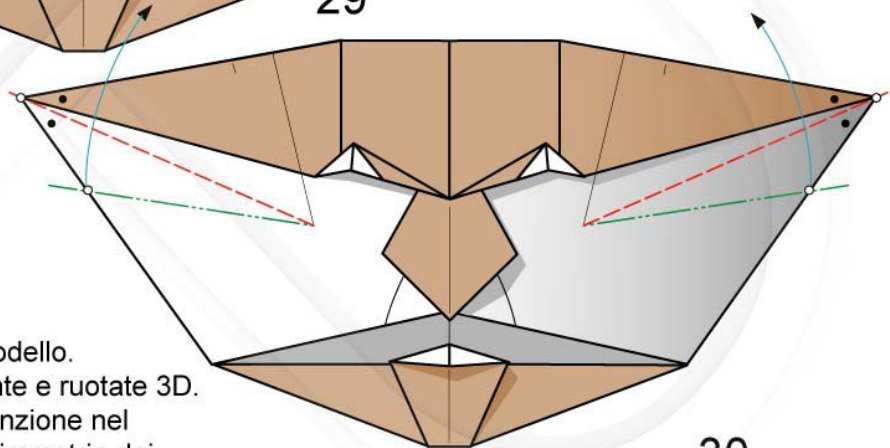

Chiudete la bocca del modello.
2 pieghe a valle, 2 a monte e ruotate 3D.
Prestate la massima attenzione nel
posizionamento e nella simmetria dei
punti di convergenza nelle guance

30

20

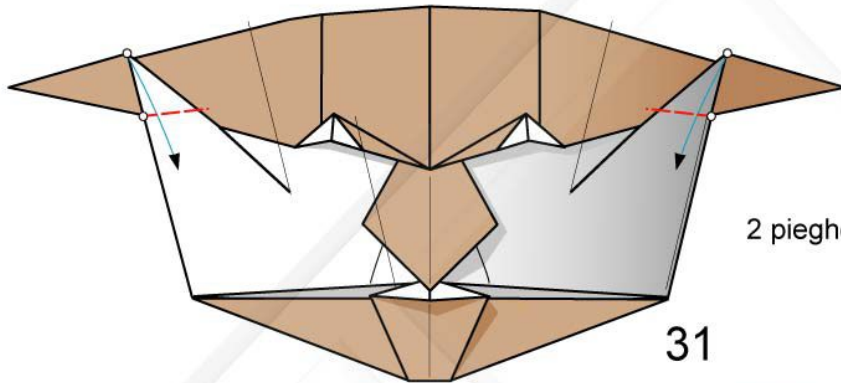

2 pieghe a valle e ruotate 3D

31

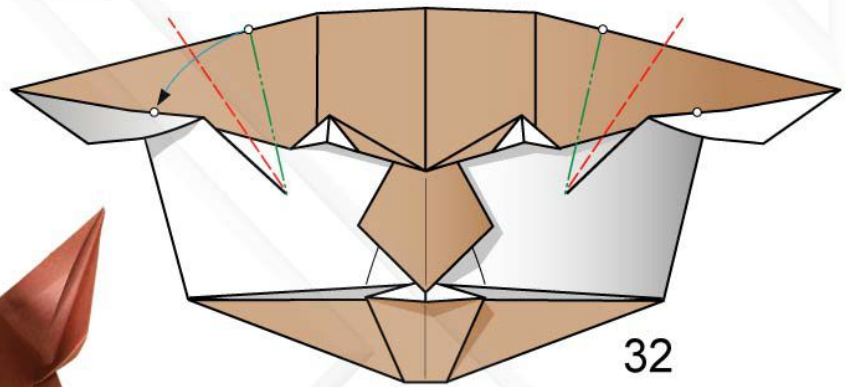

32

2 pieghe a valle e 2 a monte e ruotate 3D formando le orecchie

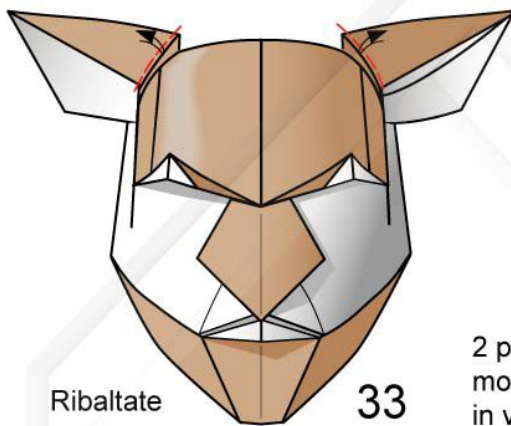

Ribaltate

33

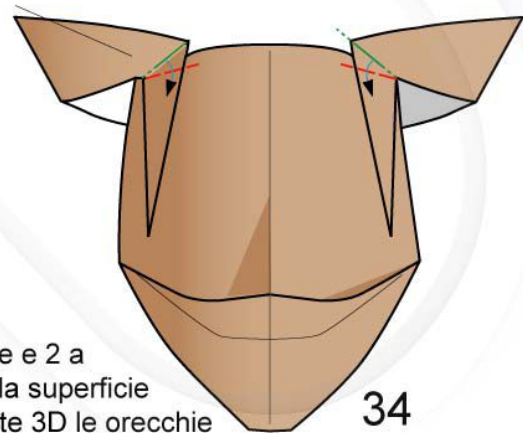

2 pieghe a valle e 2 a monte solo sulla superficie in vista e ruotate 3D le orecchie

34

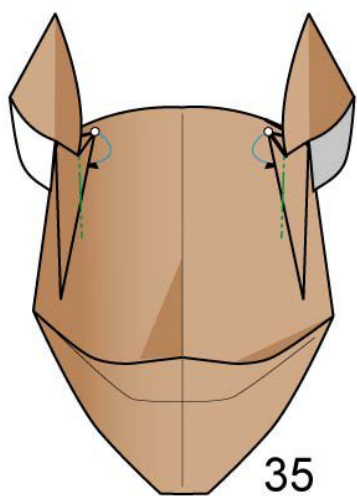

35

Ruotando 2 pieghe a monte bloccate le orecchie e ribaltate

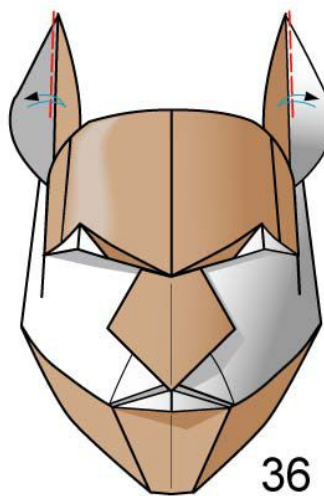

36

2 pieghe a valle

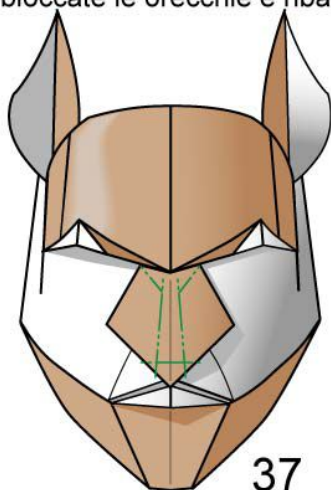

37

5 pieghe a monte morbide

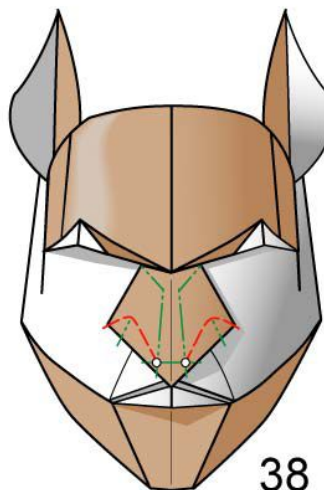

38

2 pieghe a valle e 2 a monte

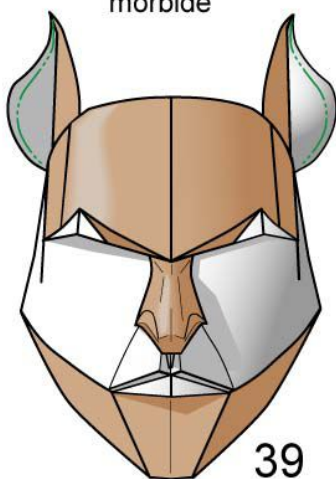

39

2 pieghe a monte

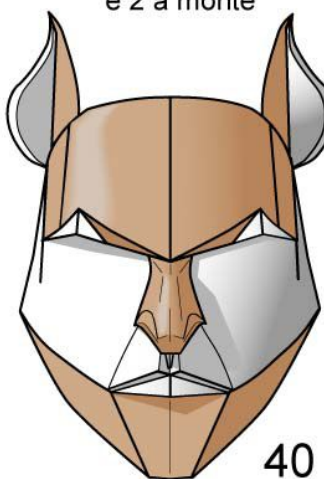

40

Licantropo completato

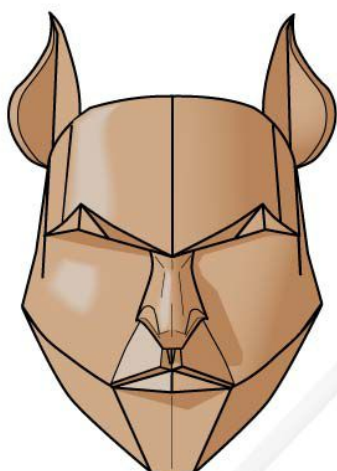

Maschera di Licantropo ultimata realizzata con cartoncino monocolore

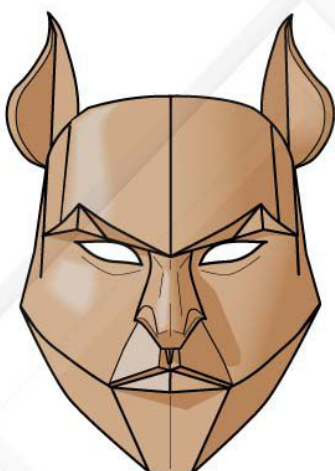

Maschera di Licantropo con occhi ritagliati

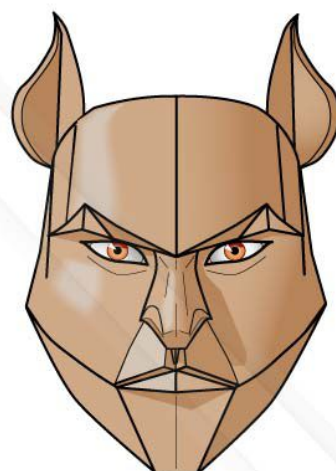

Maschera di Licantropo con occhi disegnati o incollati



VISTA DALL'ALTO



PROFILO



FRONTE



RETRO



VISTA DAL BASSO

TUTANKAMON



Questo modello raffigura la bellissima maschera funeraria in oro e smalti del faraone egiziano. Partite da un foglio di cartoncino quadrato monocolore di 45 cm di lato.

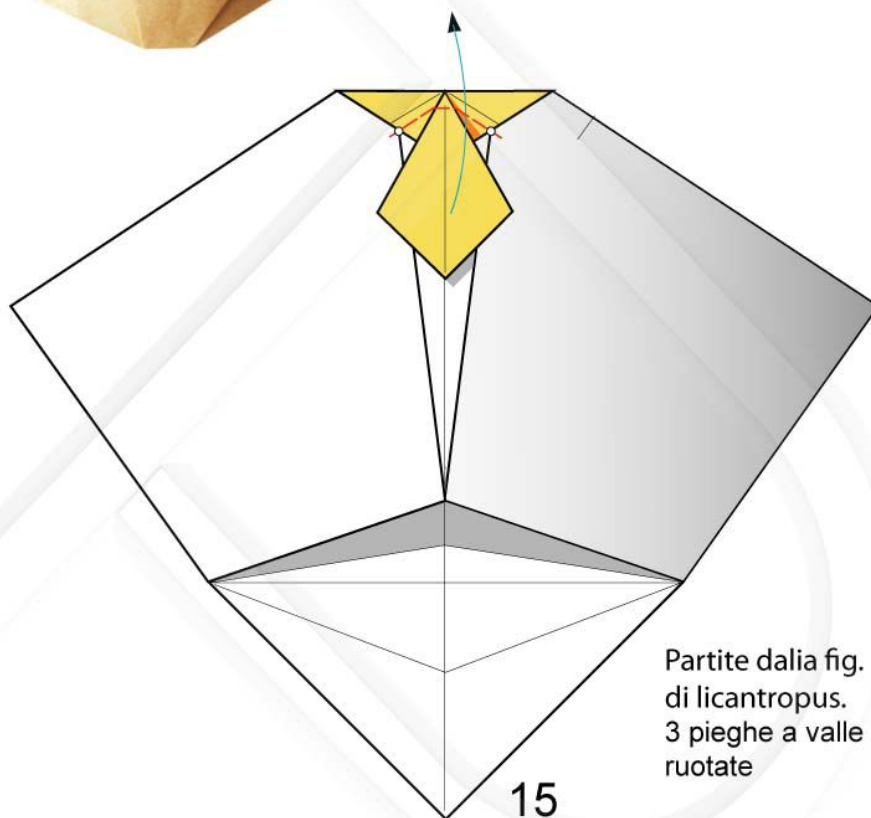

Partite dalla fig. 14 di licantropus. 3 pieghe a valle e ruotate

24

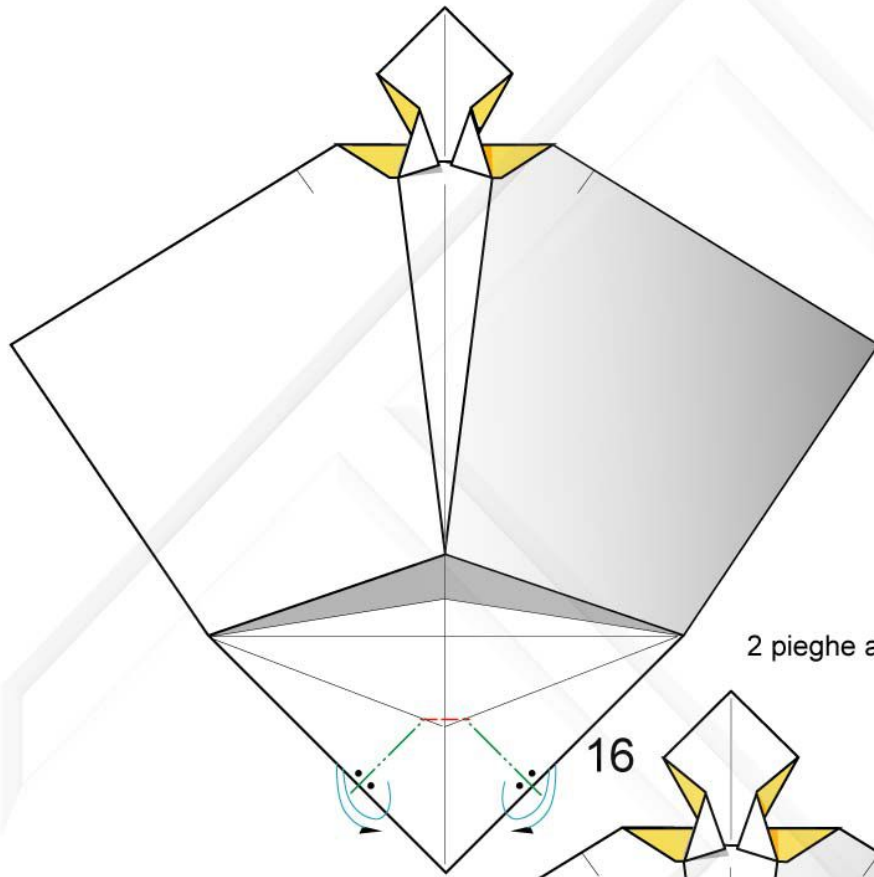

2 pieghe a monte ed 1 a valle

16

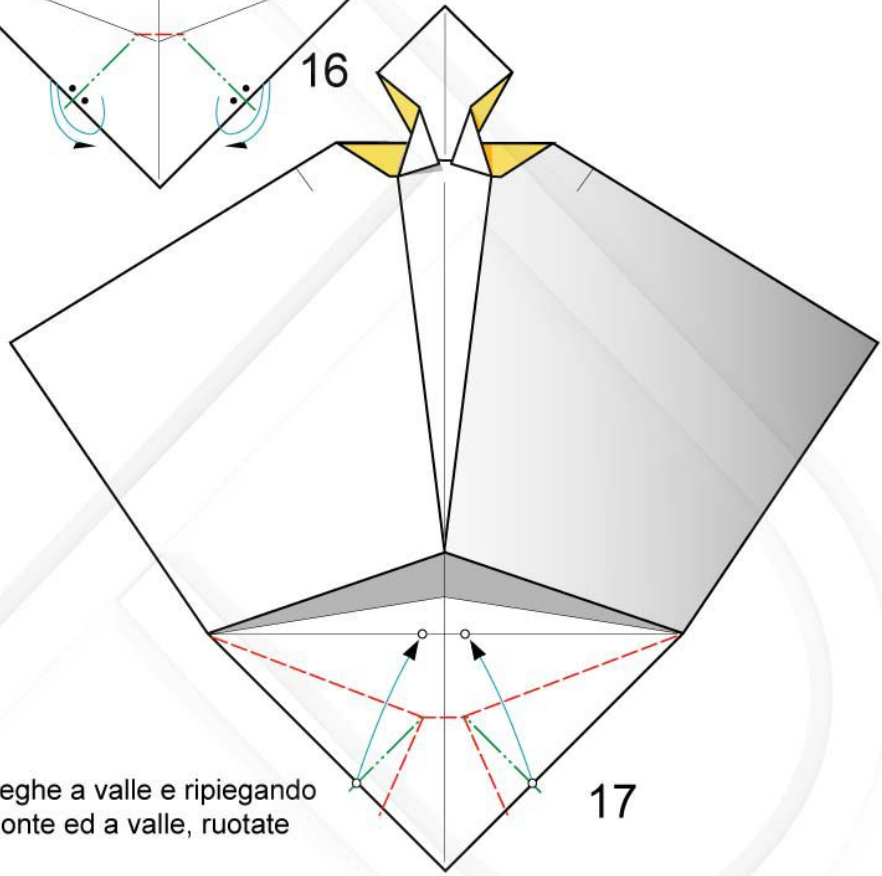

2 pieghe a valle e ripiegando a monte ed a valle, ruotate

17

25

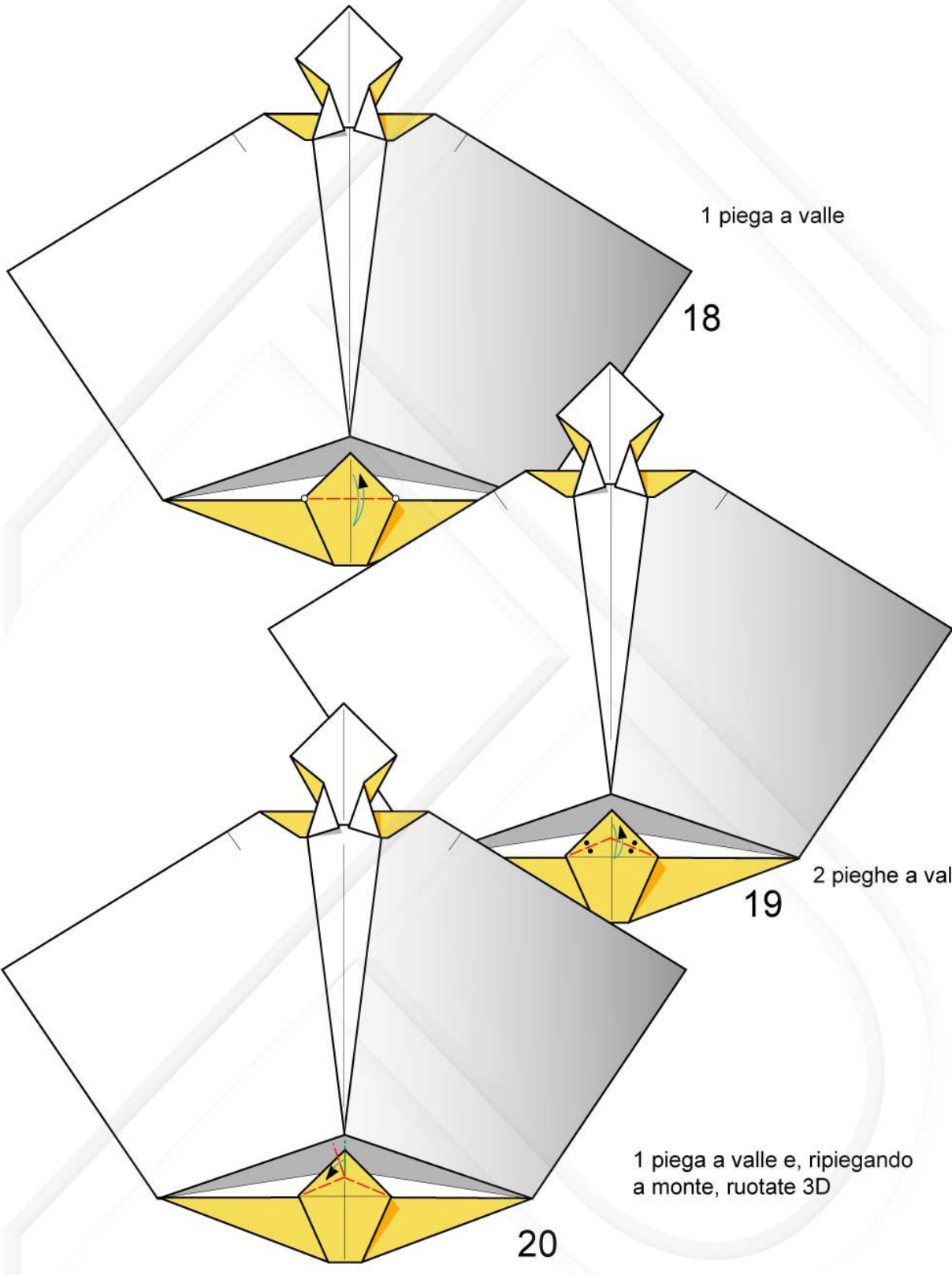

1 piega a valle

18

2 pieghe a valle

19

1 piega a valle e, ripiegando a monte, ruotate 3D

20

26

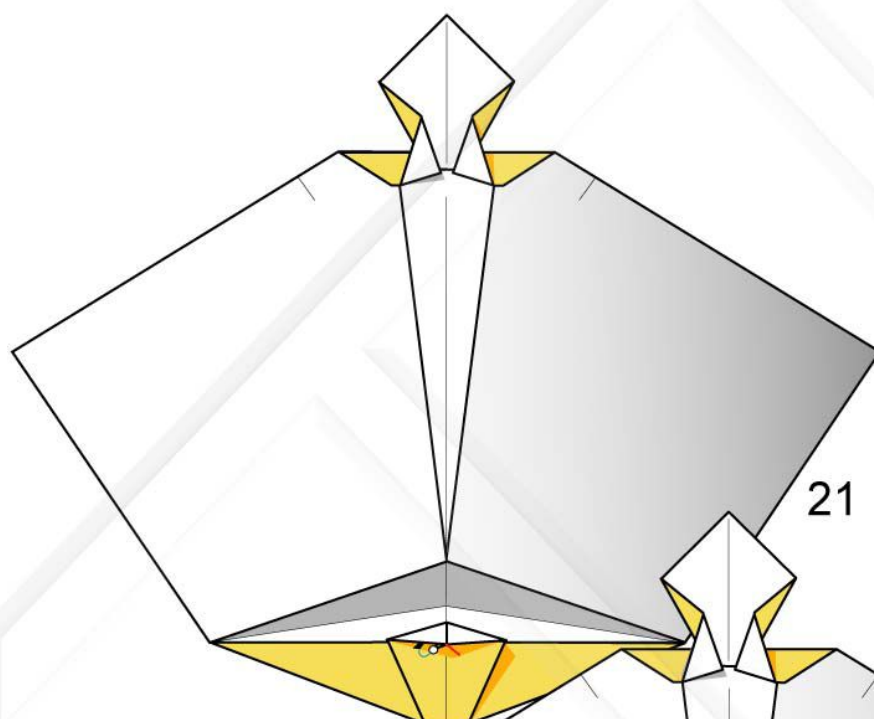

mediante 1 piega a valle
ruotate il vertice inferiore
bloccando il labbro

21

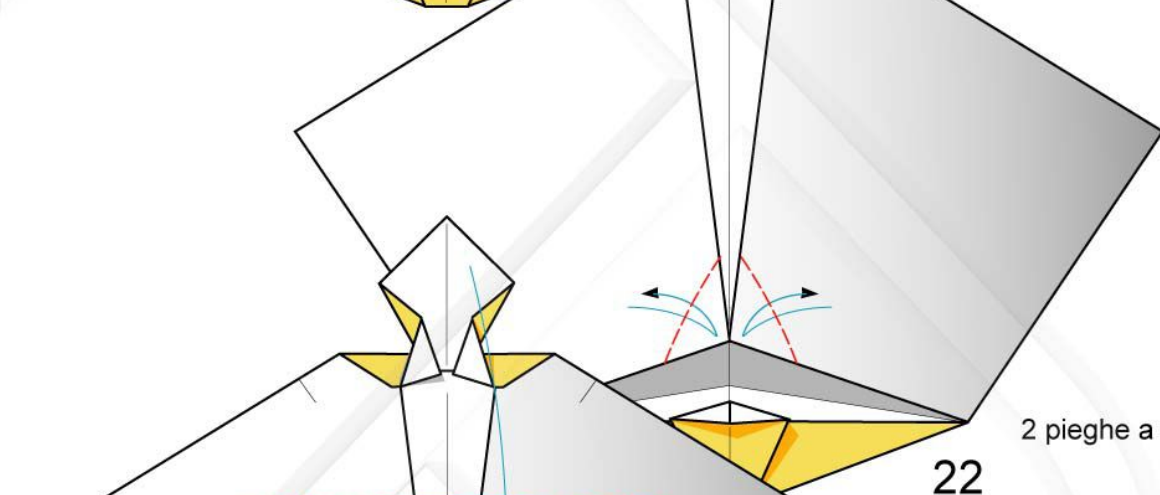

2 pieghe a valle

22

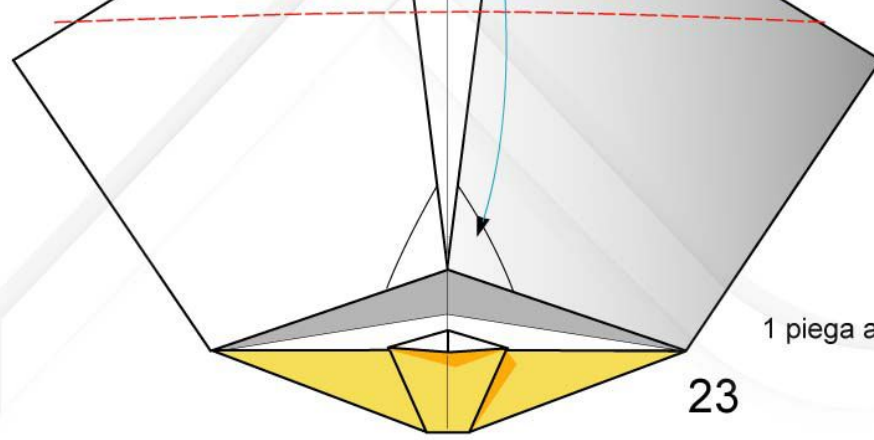

1 piega a valle e ruotate

23

27

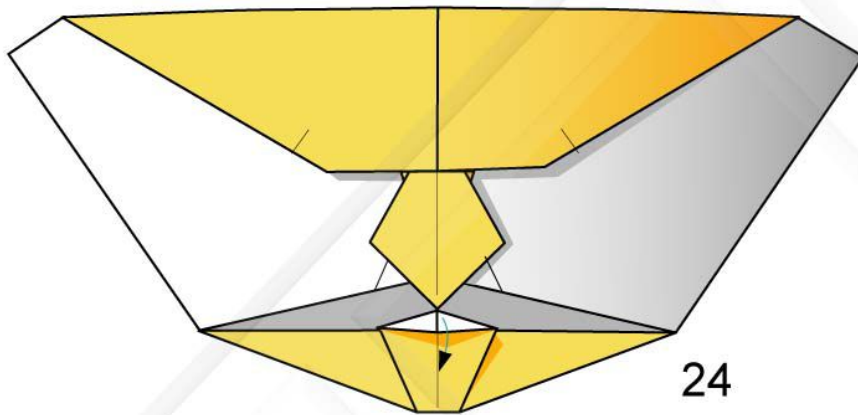

24

abbassate il labbro

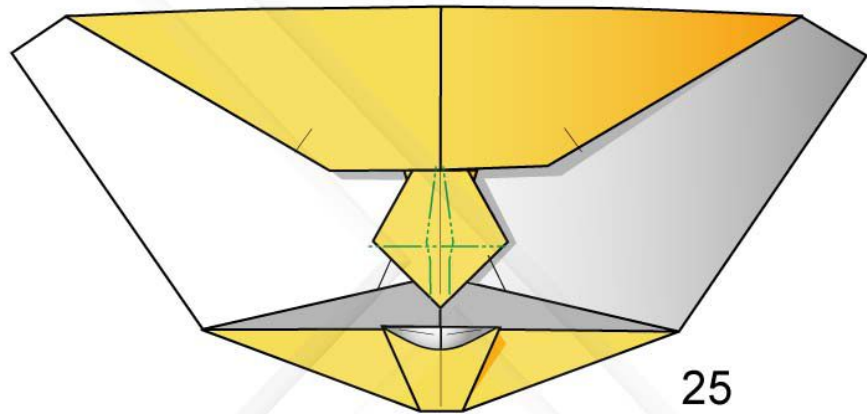

25

3 pieghe a valle, quelle verticali devono essere morbide

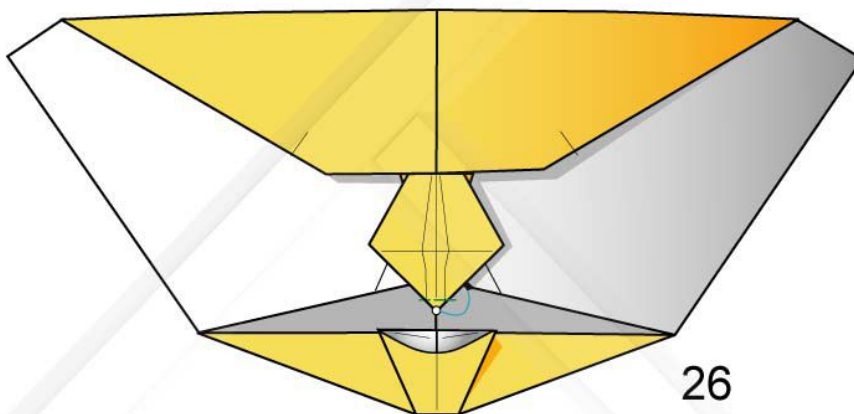

26

1 piega a monte e ruotate

28

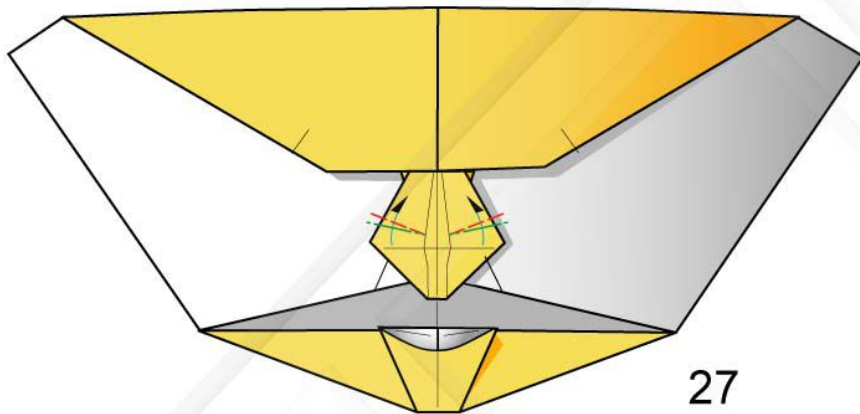

2 pieghe a valle, 2 a monte e ruotate 3D

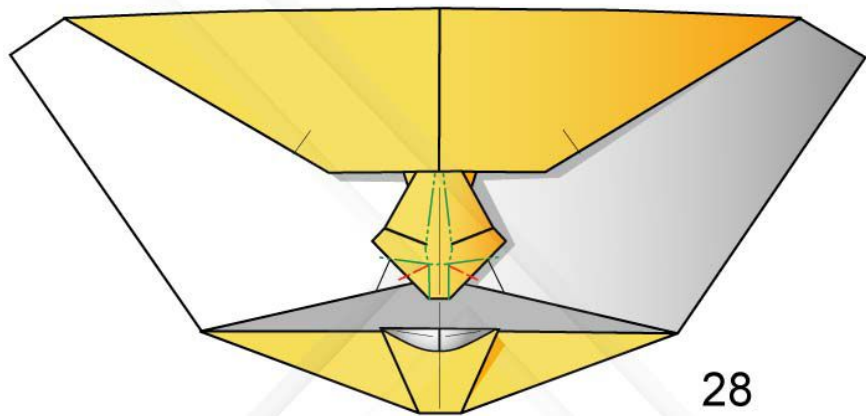

2 pieghe a valle e, ripiegando a monte,
ruotate 3D sagomando naso e narici



29

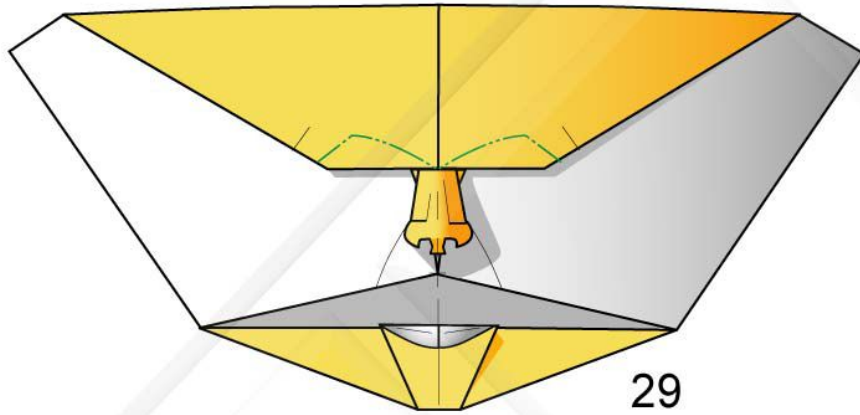

29

2 pieghe a monte

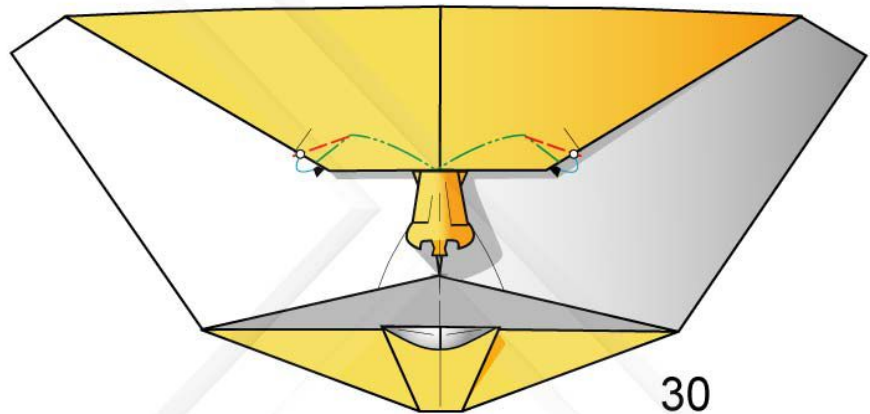

30

2 pieghe a valle e, ripiegando a monte, ruotate 3D

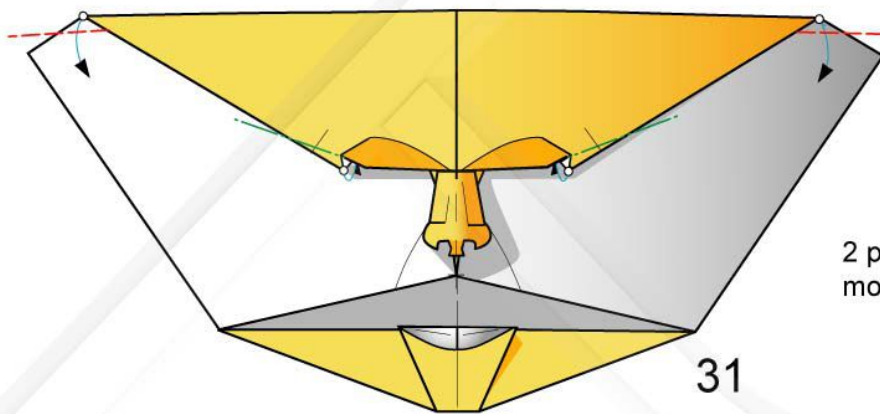

31

2 pieghe a valle, 2 a monte e ruotate 3D

30

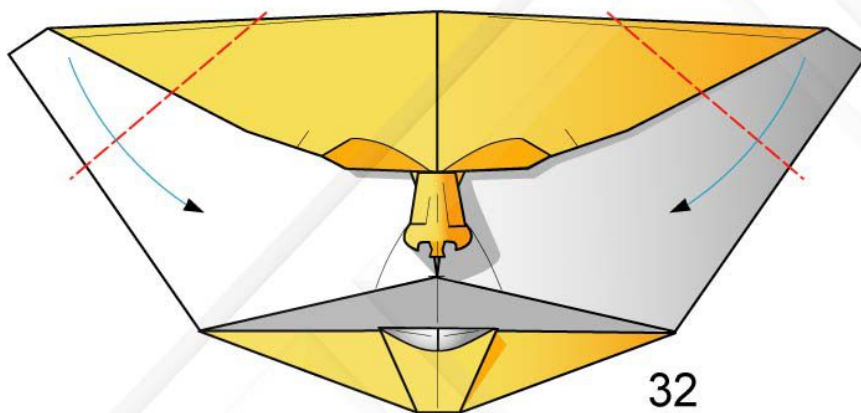

32

2 pieghe a valle e ruotate

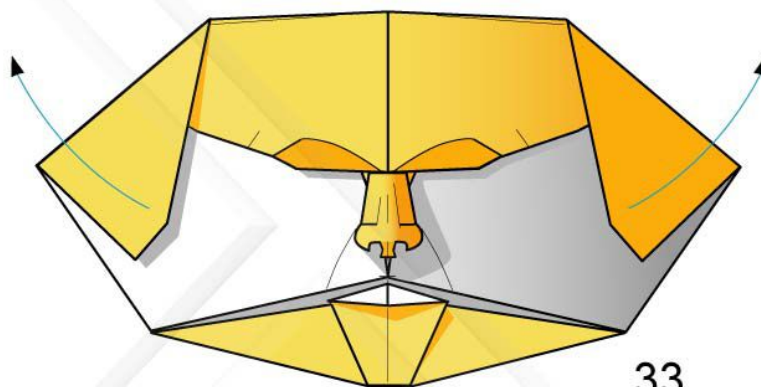

33

Riaprite

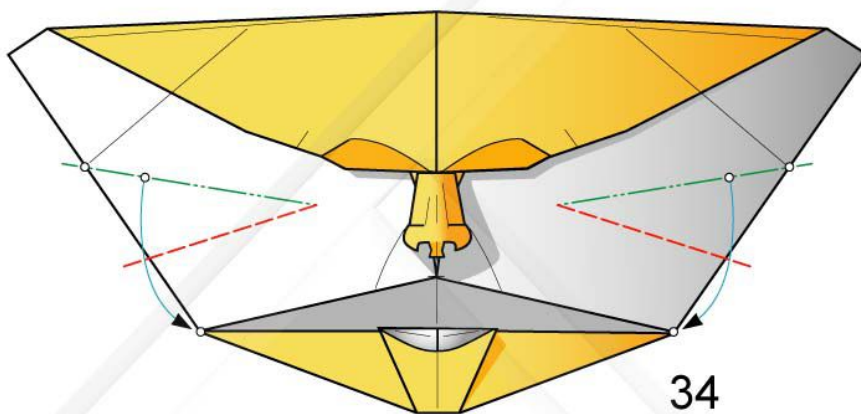

34

Chiudete la bocca del modello.
2 pieghe a valle, 2 a monte e ruotate 3D.
Prestate la massima attenzione nel
posizionamento e nella simmetria dei
punti di convergenza nelle guance

31

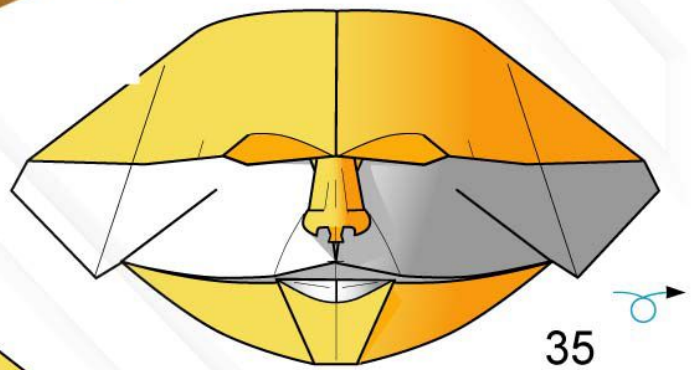

Ribaltate

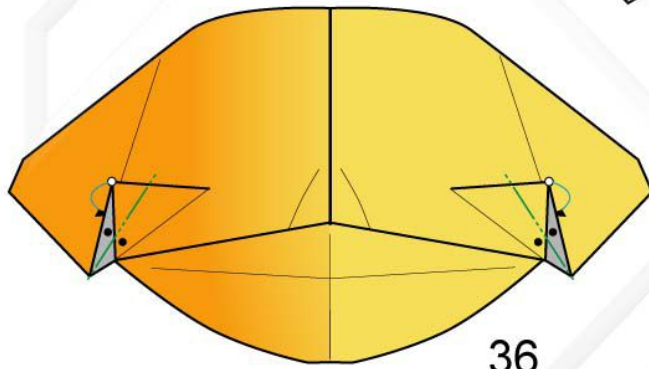

2 pieghe a monte e ruotate
all'interno bloccando il modello

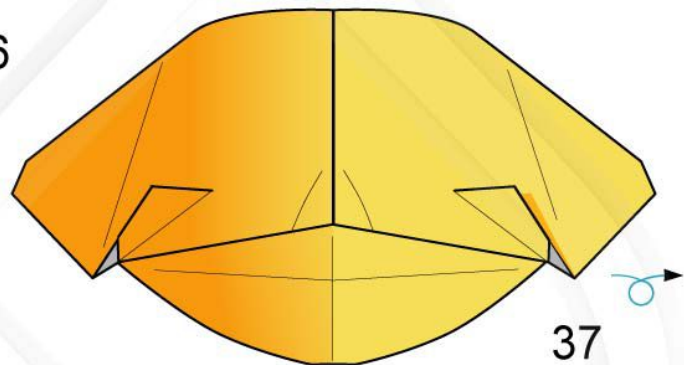

Ribaltate

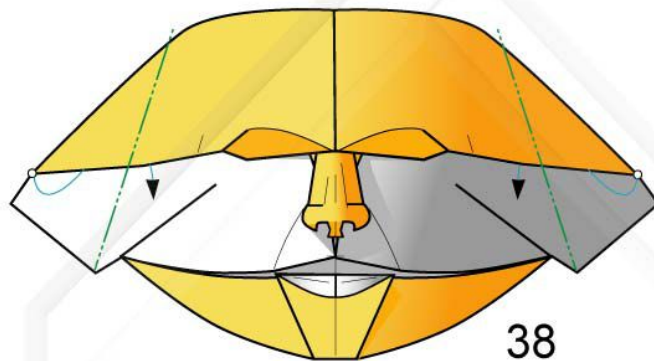

2 pieghe rovesce interne

32

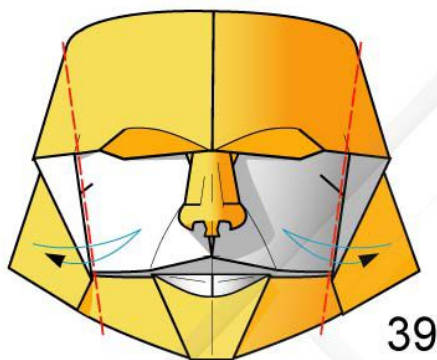

39

2 pieghe a valle

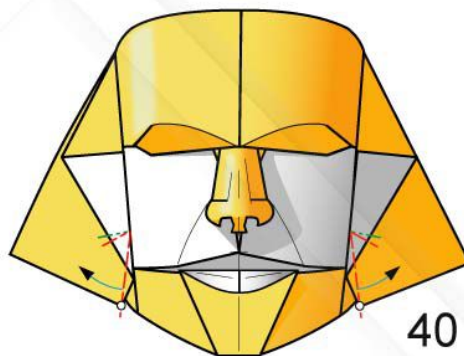

40

4 pieghe a valle e 2 a monte
solo sulla sup. in vista e ruotate

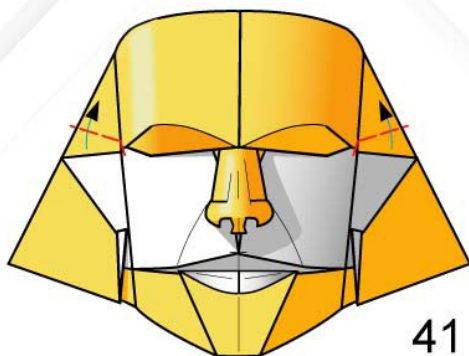

41

2 pieghe a valle e ruotate
3D per formare le orecchie

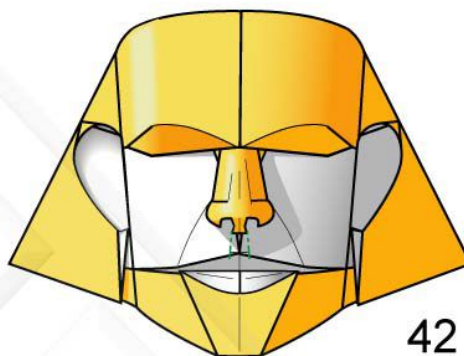

42

2 piccole pieghe a monte

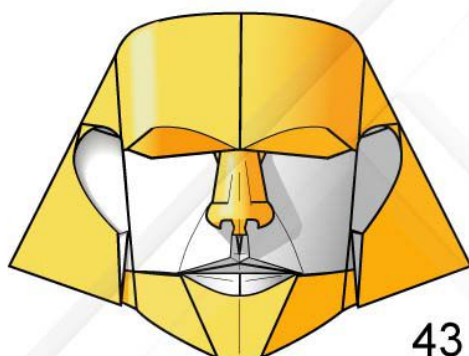

43

Maschera di Tutankamon ultimata

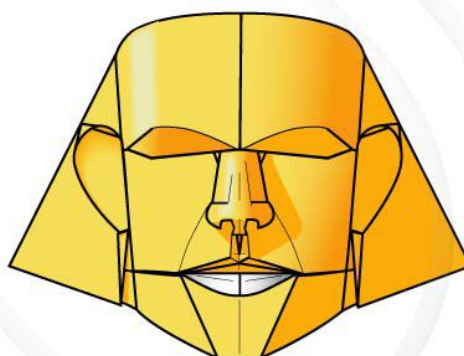

Maschera di Tutankamon ultimata
realizzata con cartoncino monocoloro

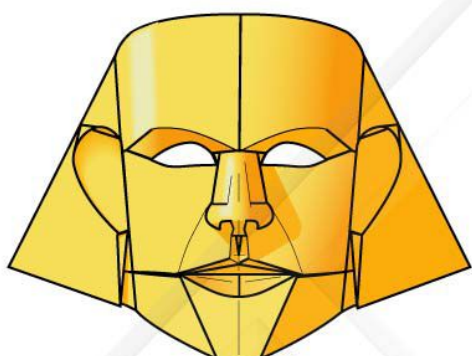

Maschera di Tutankamon
con occhi ritagliati

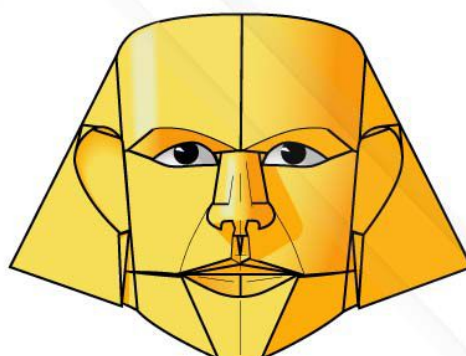

Maschera di Tutankamon
con occhi disegnati o incollati



VISTA DALL'ALTO



PROFILO



FRONTE



RETRO



VISTA DAL BASSO

SPOOK



Questa maschera assomiglia all'eroe vulcaniano della serie Star Trek. Adoperate un foglio di cartoncino quadrato di 45 cm di lato

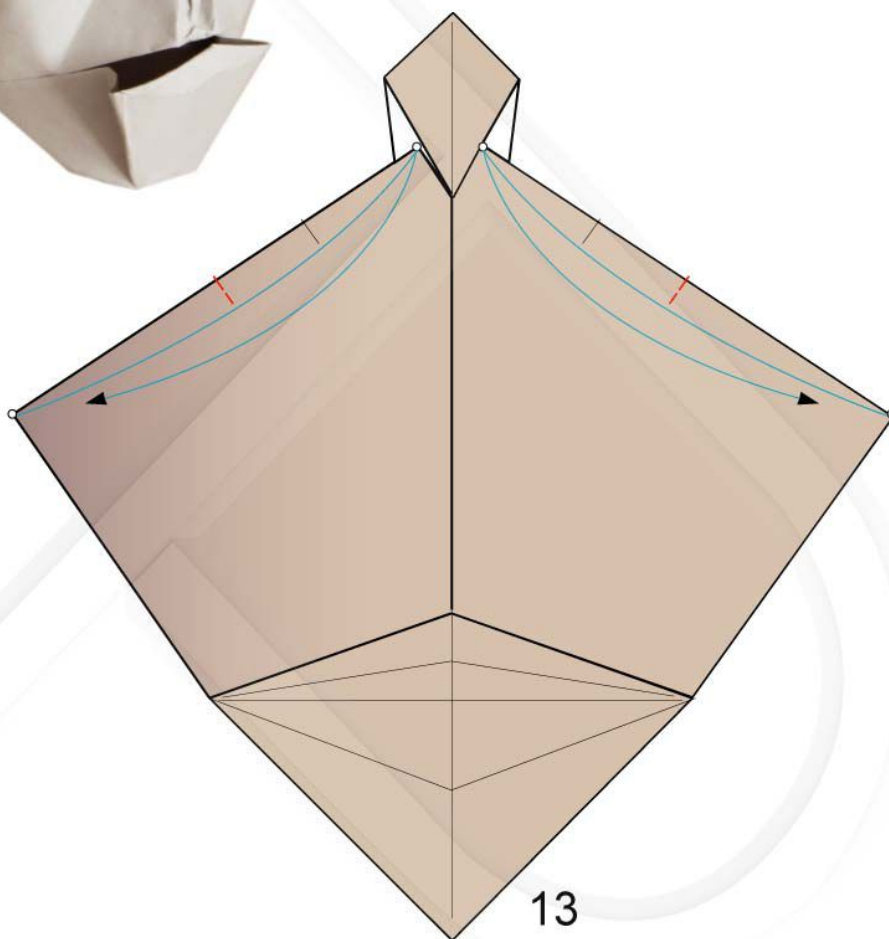

Partite dalla fig. n. 12 di "Licantropo".
2 piccole pieghe a valle

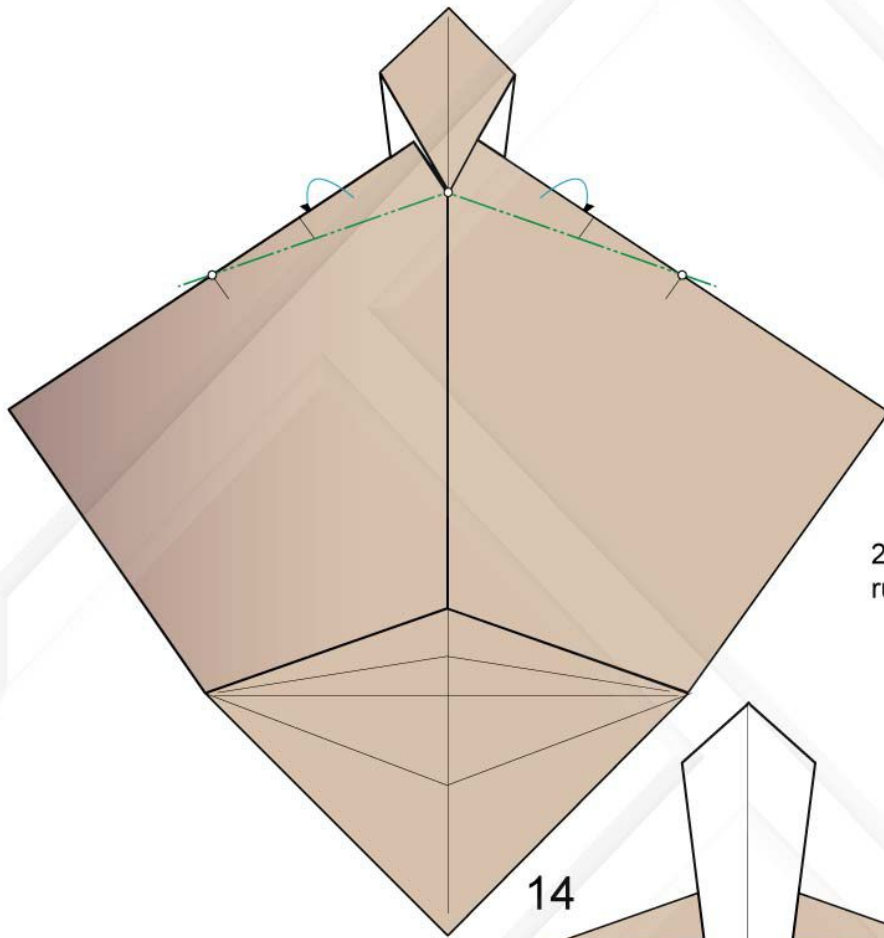

2 pieghe a monte,
ruotate e ribaltate

14

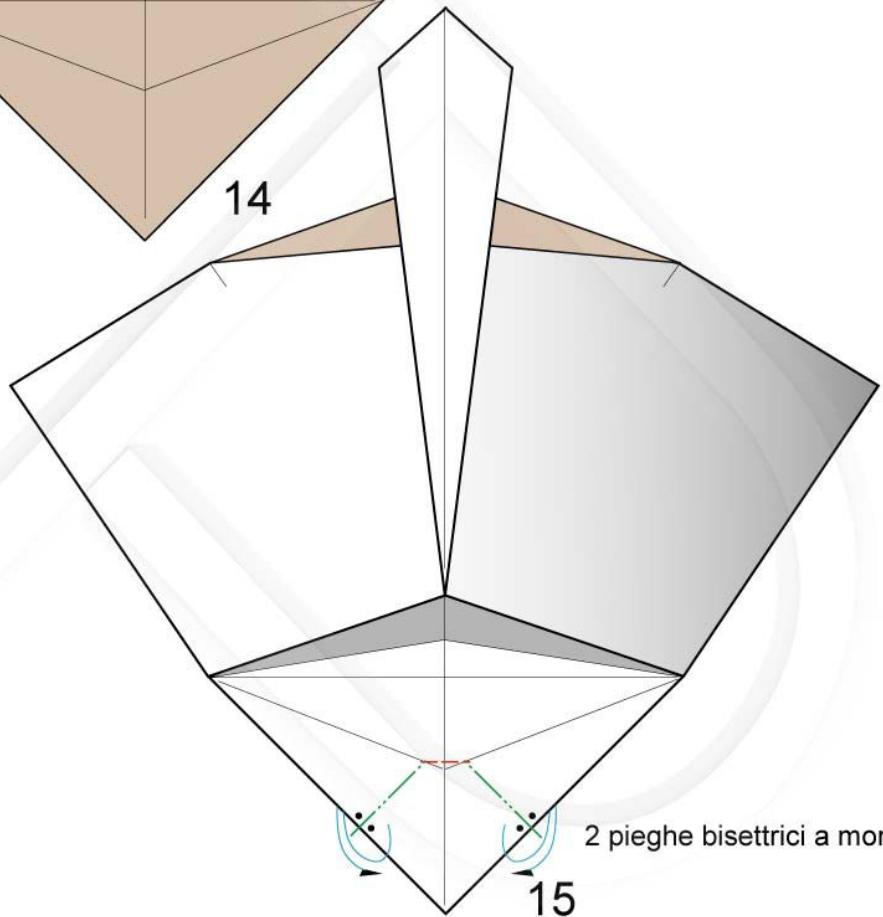

2 pieghe bisettrici a monte

15

36

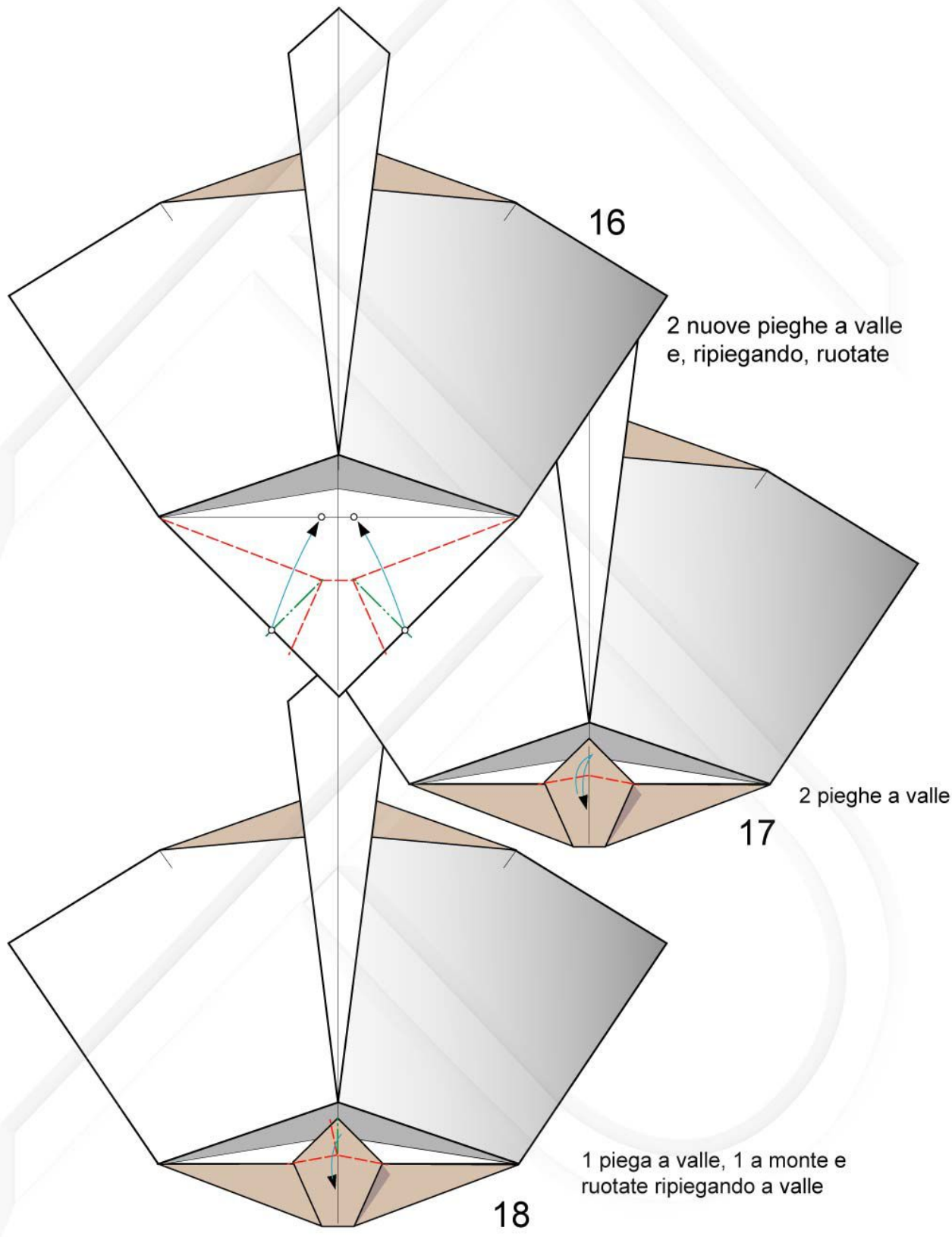

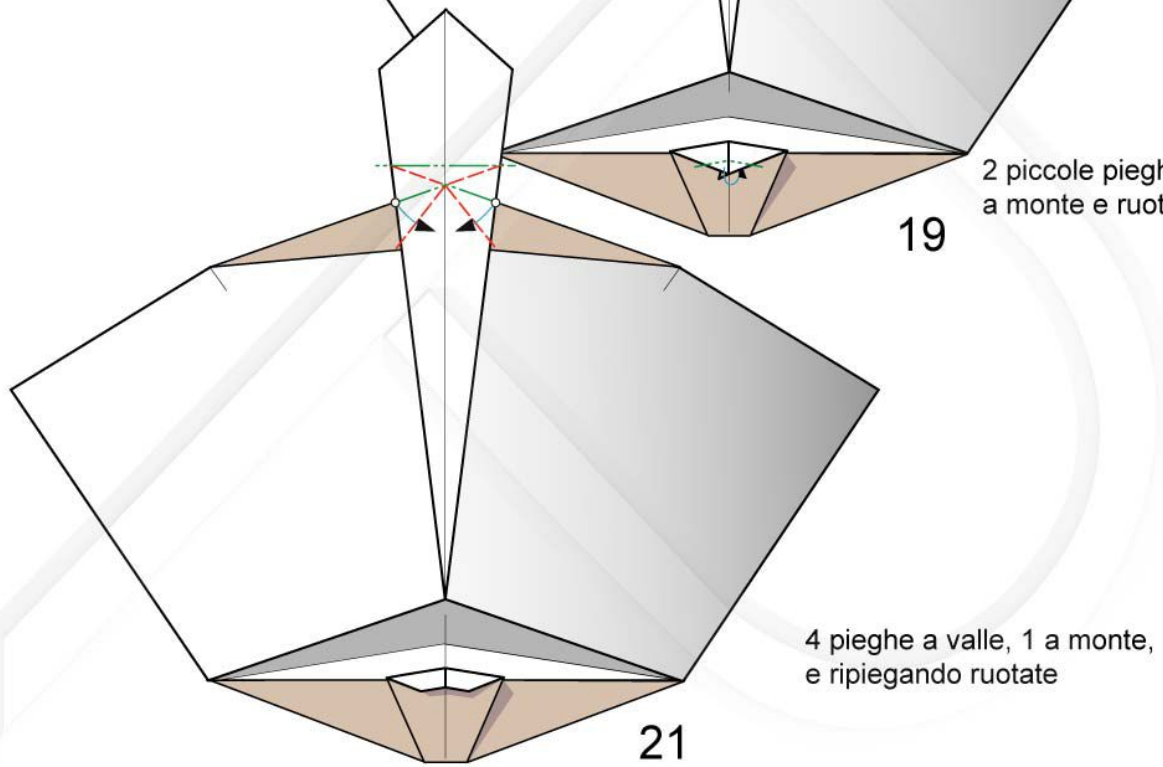
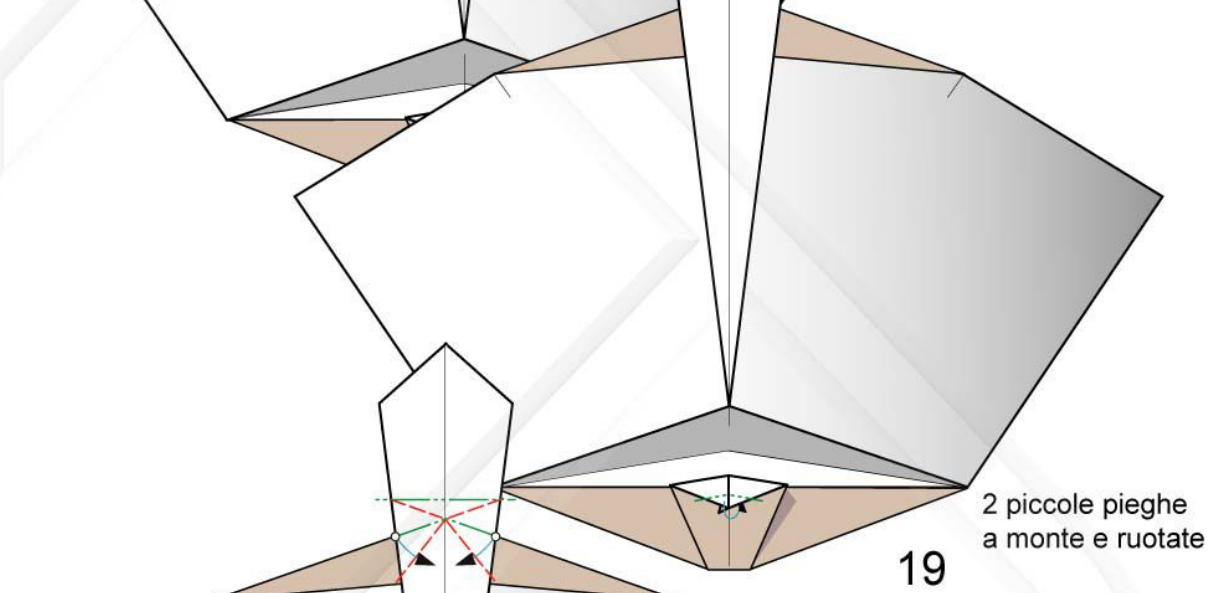
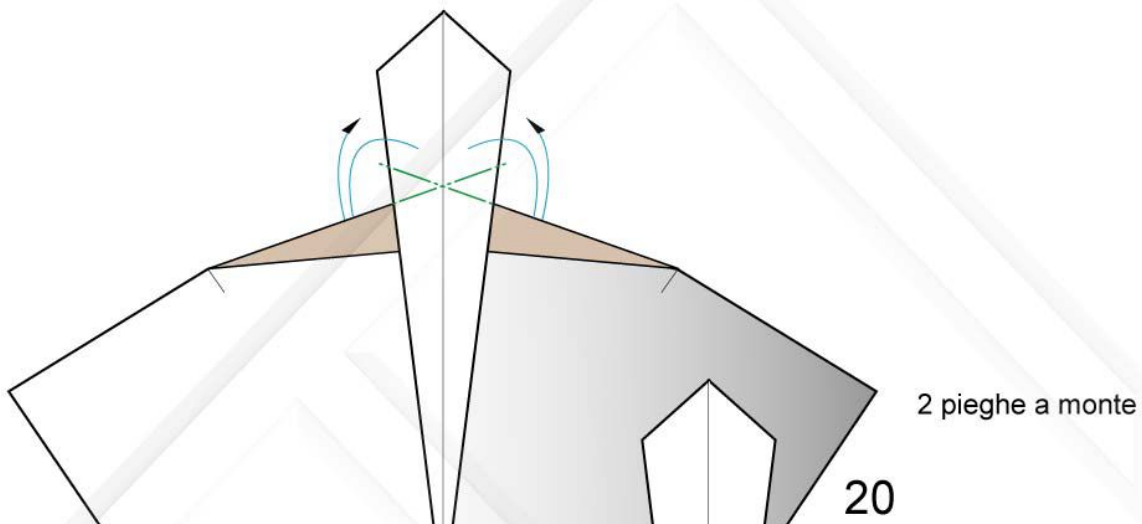

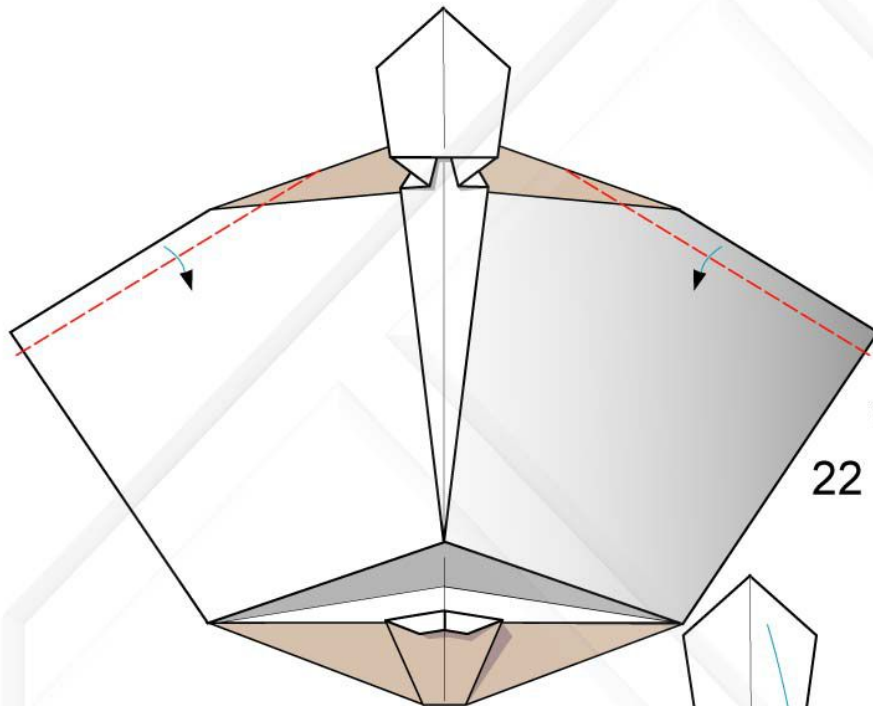

2 pieghe a valle e ruotate

22

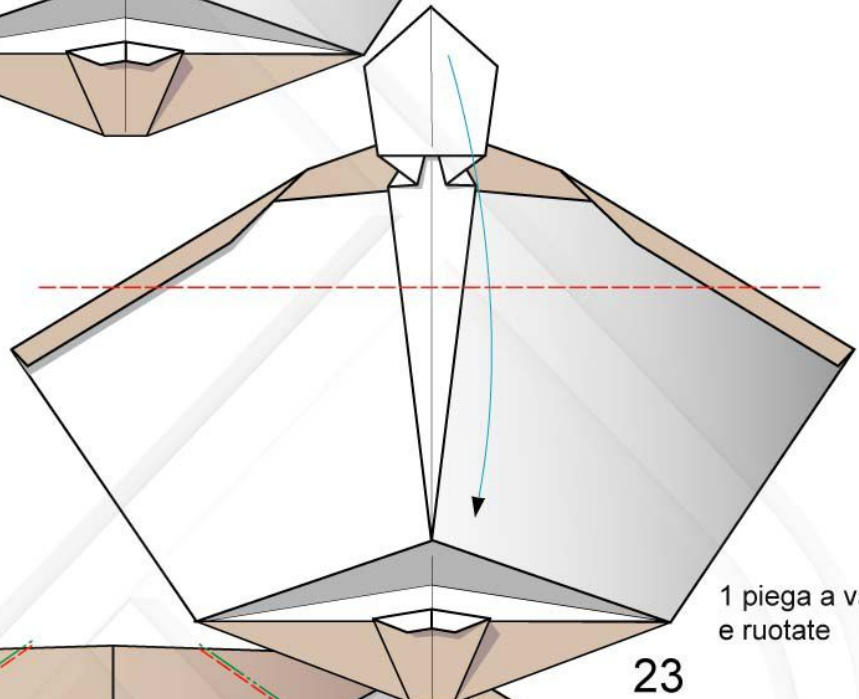

1 piega a valle e ruotate

23

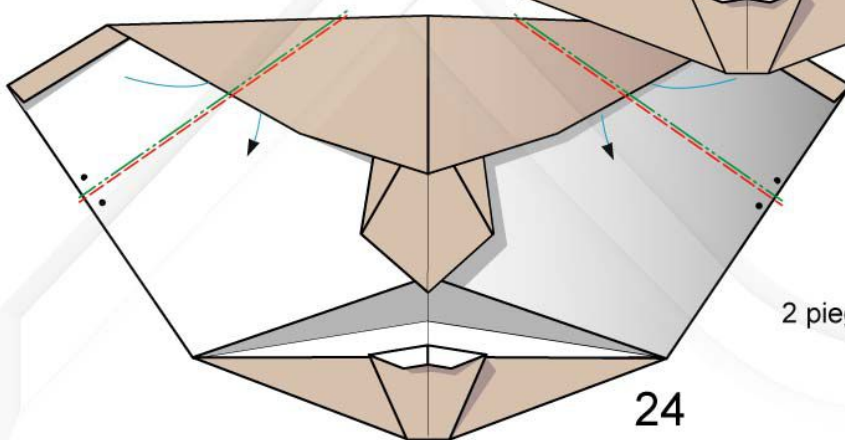

2 pieghe rovesce interne

24

39

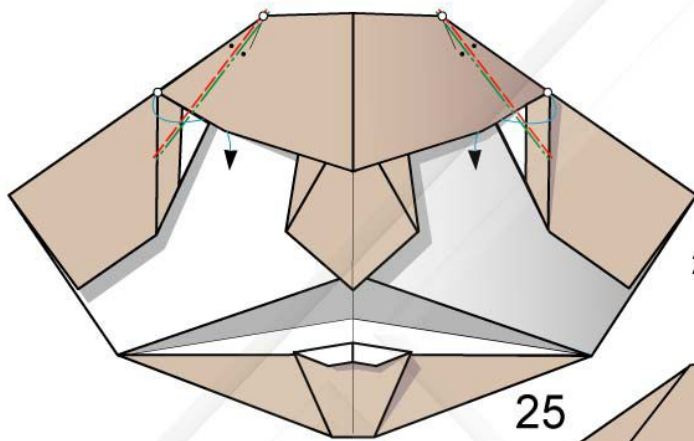

2 pieghe rovesce interne

25

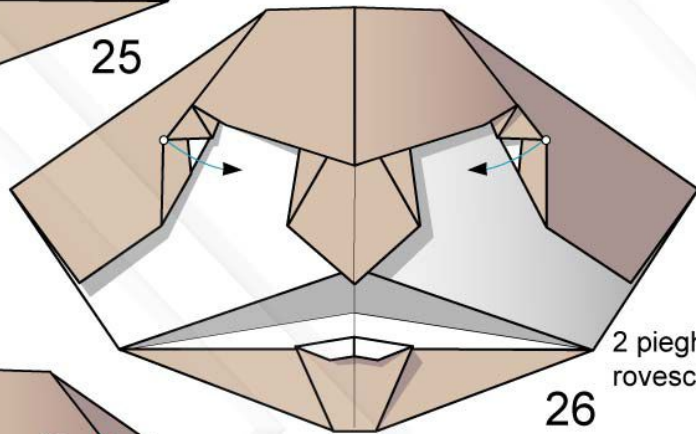

2 pieghe rovesce interne

26

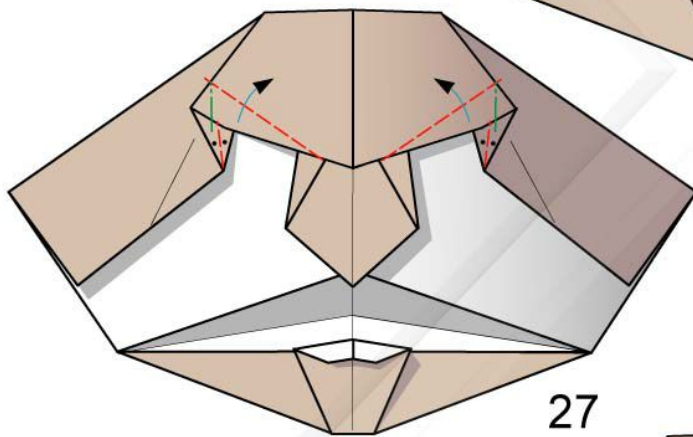

4 pieghe a valle, 2 a monte e ruotate

27

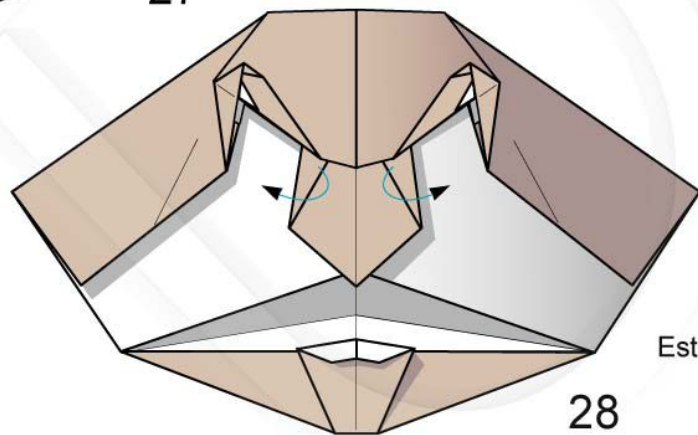

Estraete

28

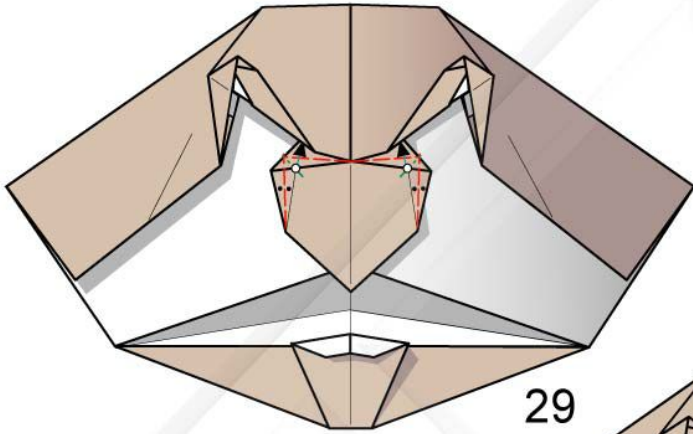

4 pieghe a valle e ruotate

29

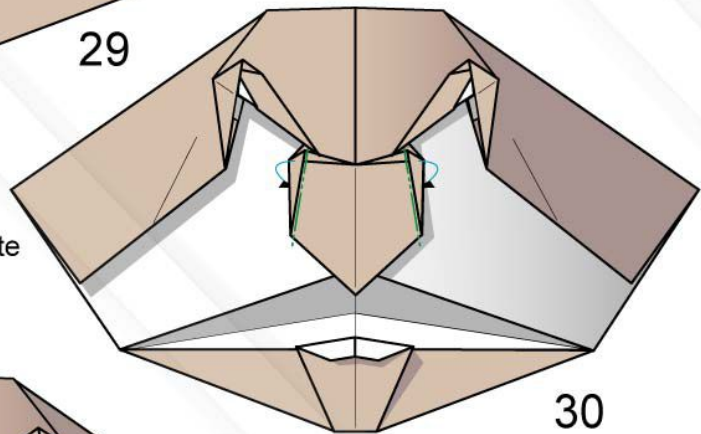

2 pieghe a monte e ruotate

30

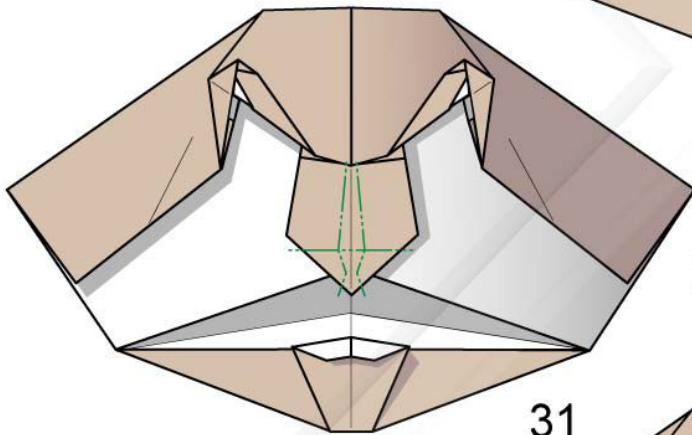

3 pieghe a monte, le verticali devono essere morbide

31

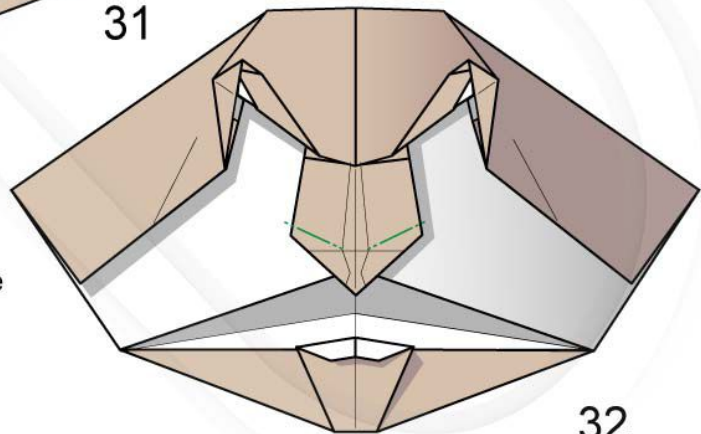

2 pieghe a monte

32

41

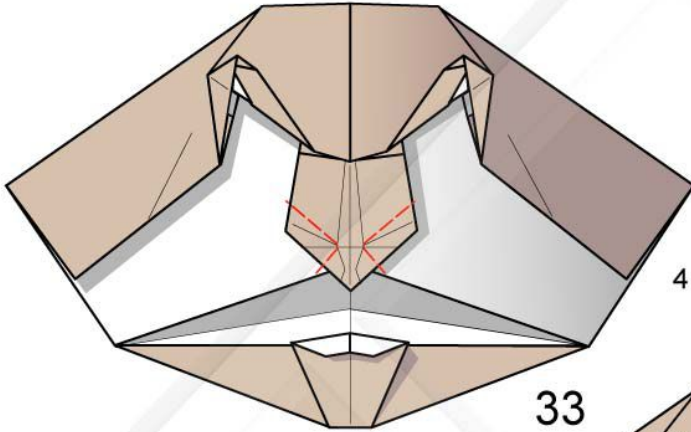

4 pieghe a valle

33

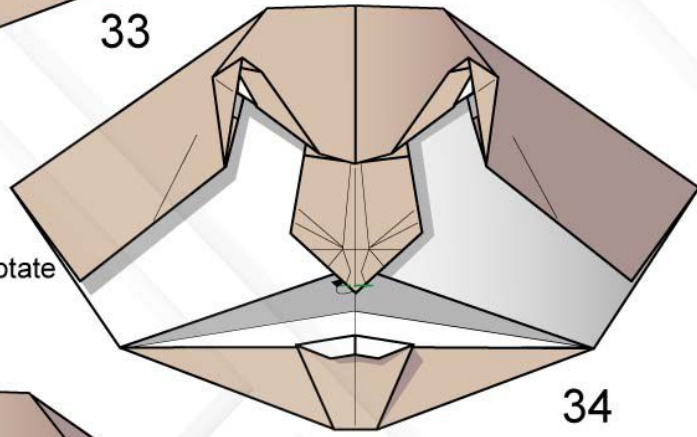

1 piega a monte e ruotate

34

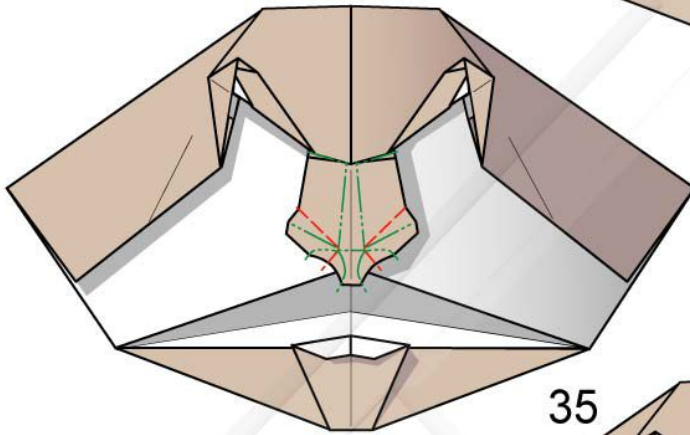

Ripiegando a valle ed a monte ruotate 3D

35

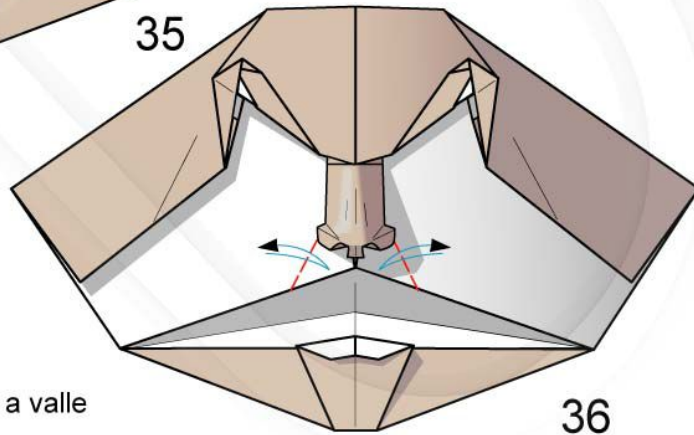

2 pieghe a valle

36

42

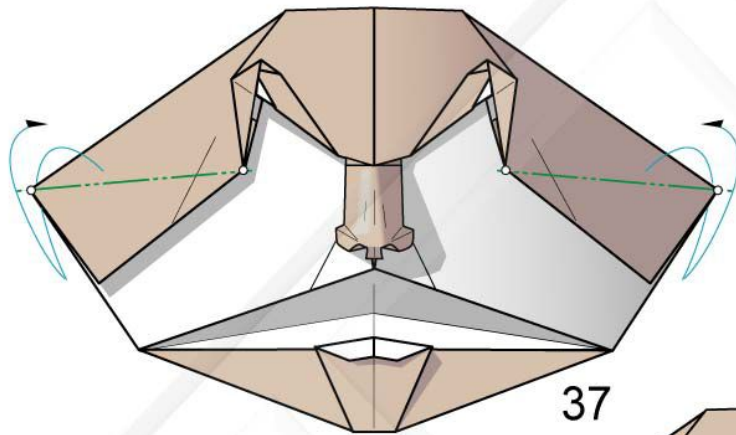

2 pieghe a monte

37

2 pieghe a monte e ruotate all'interno

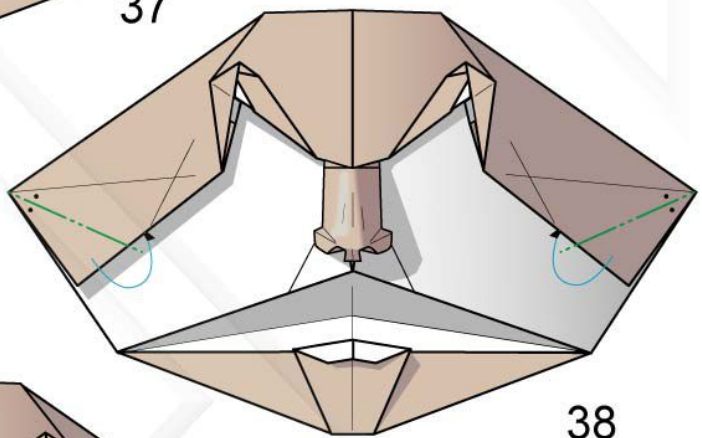

38

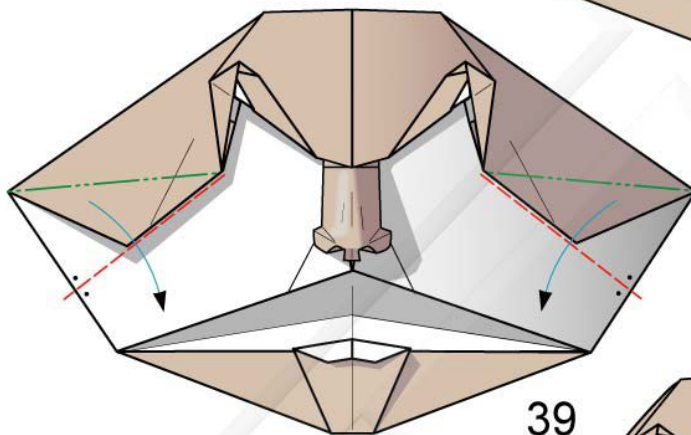

2 pieghe a valle e, ripiegando a monte, ruotate 3D

39

2 pieghe a valle e ruotate 3D

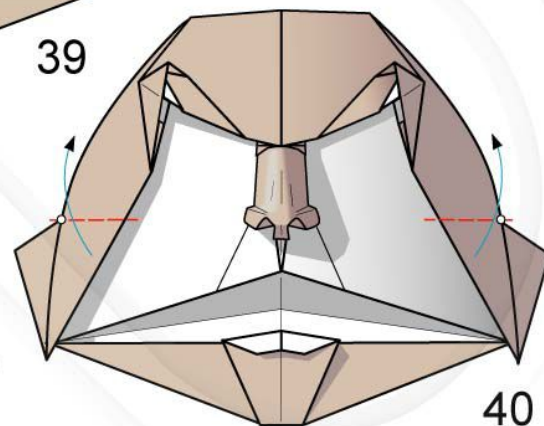

40

43

Disegni ingranditi 120 %



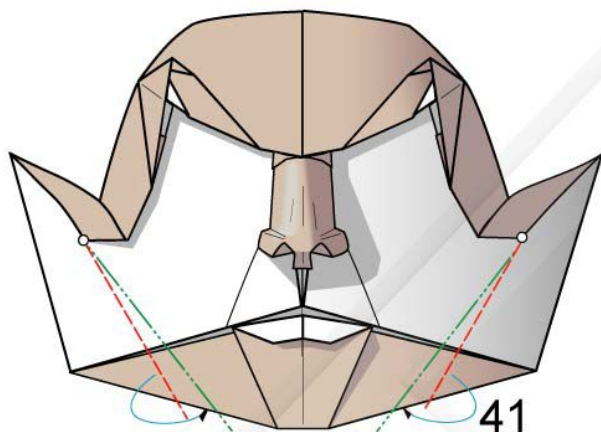

Chiudete la bocca della maschera.
2 pieghe a valle, 2 a monte e ruotate a "z"

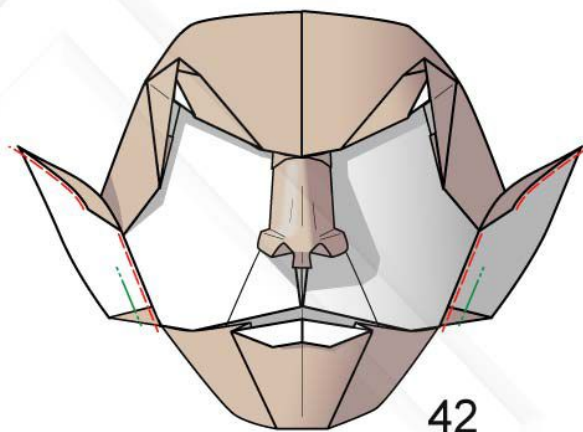

4 pieghe a valle e 2 a monte morbide

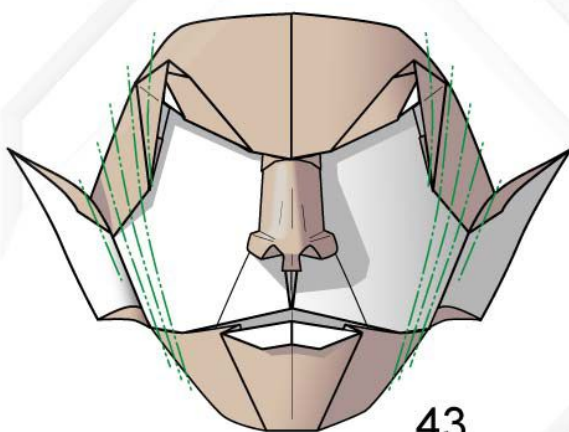

piegate morbidamente arrotondando le guance

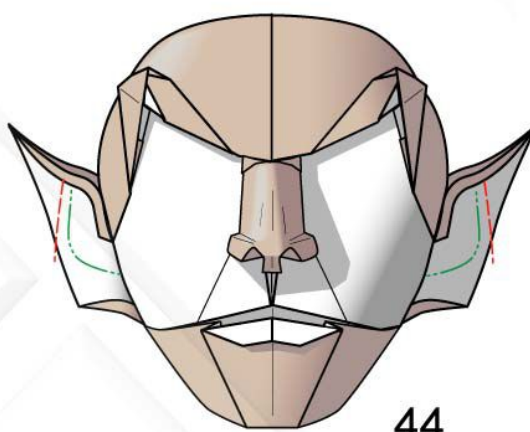

2 pieghe a valle curve e 2 a monte

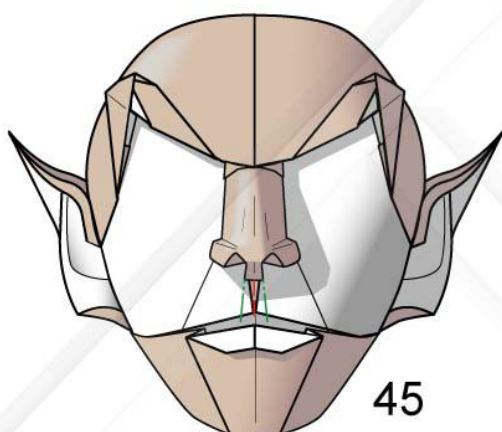

2 piccole pieghe a monte ed 1 a valle sul labbro superiore

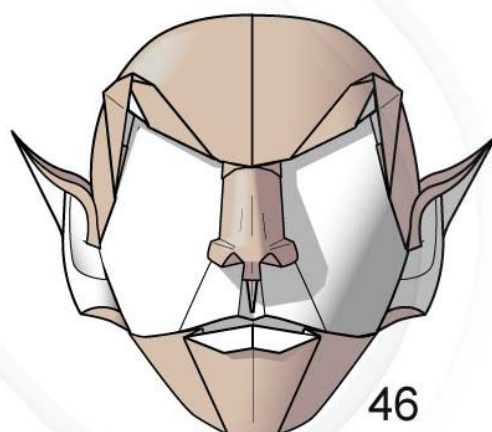

Maschera di Spook ultimata

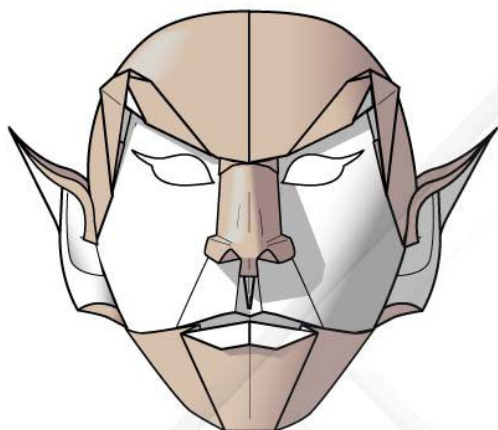

Maschera di Spook
con occhi ritagliati

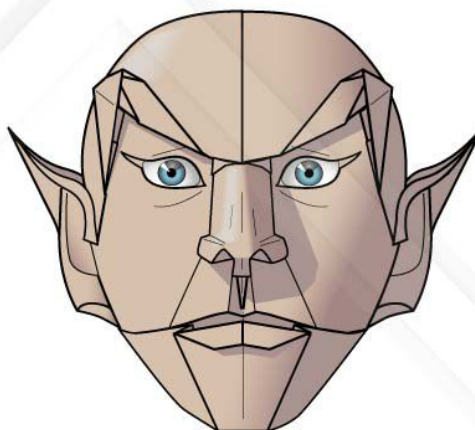

Maschera di Spook con
occhi disegnati o incollati



VISTA DALL'ALTO



PROFILO



FRONTE



RETRO



JEDI YODA



La maschera raffigura il saggio personaggio di Star Wars.
Adoperate un foglio di cartoncino quadrato monocolore di 42 cm di lato

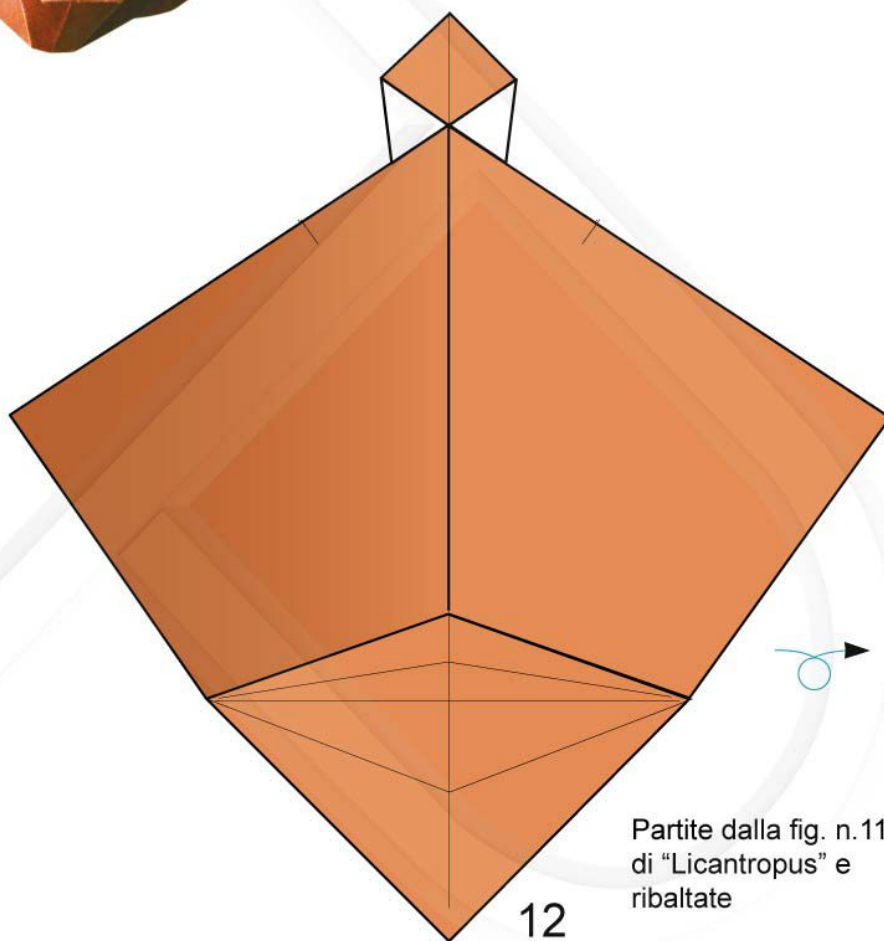

Partite dalla fig. n.11 di "Licantropus" e ribaltate

46

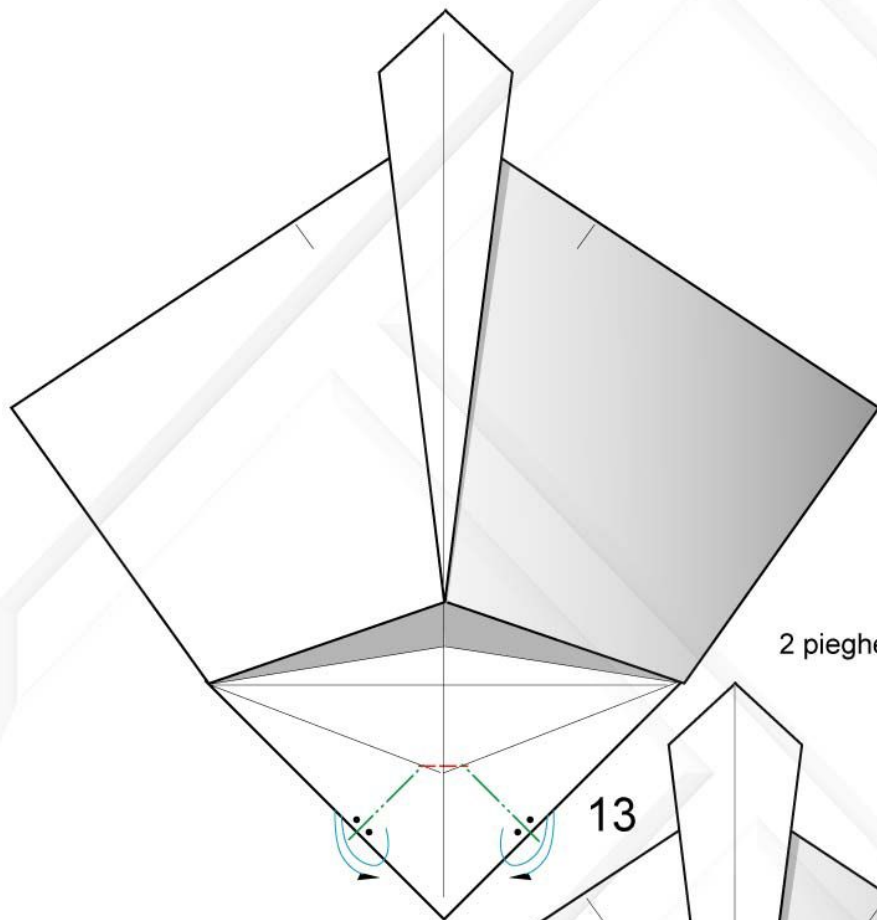

2 pieghe bisettrici a monte

13

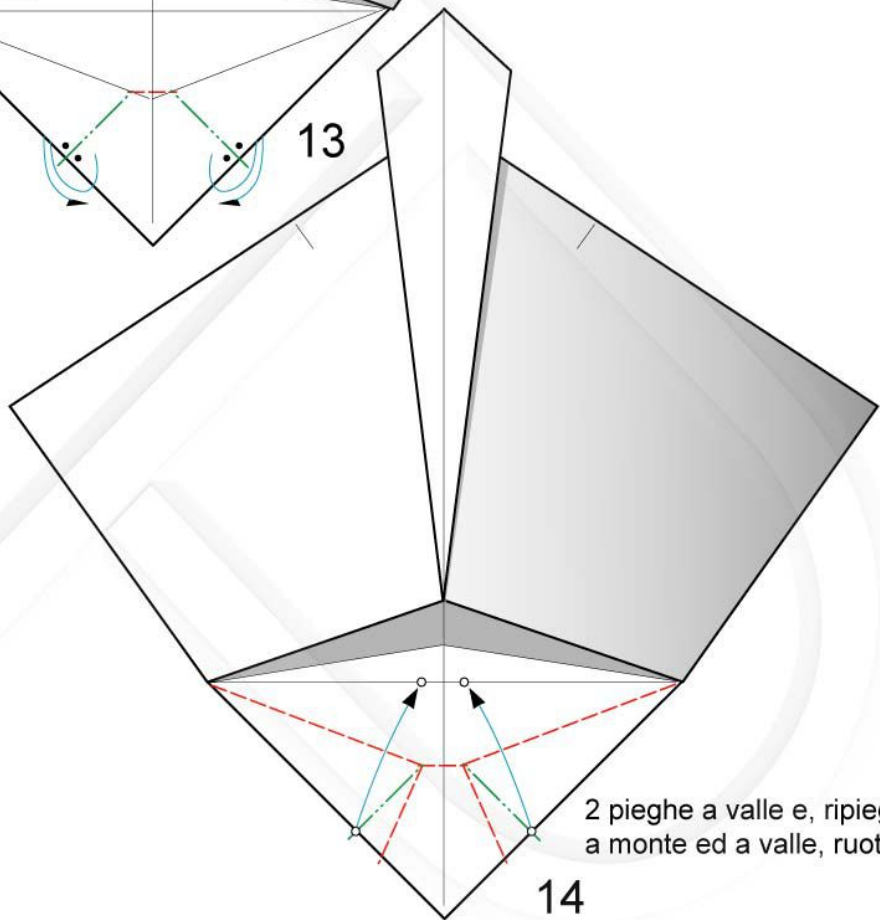

2 pieghe a valle e, ripiegando a monte ed a valle, ruotate

14

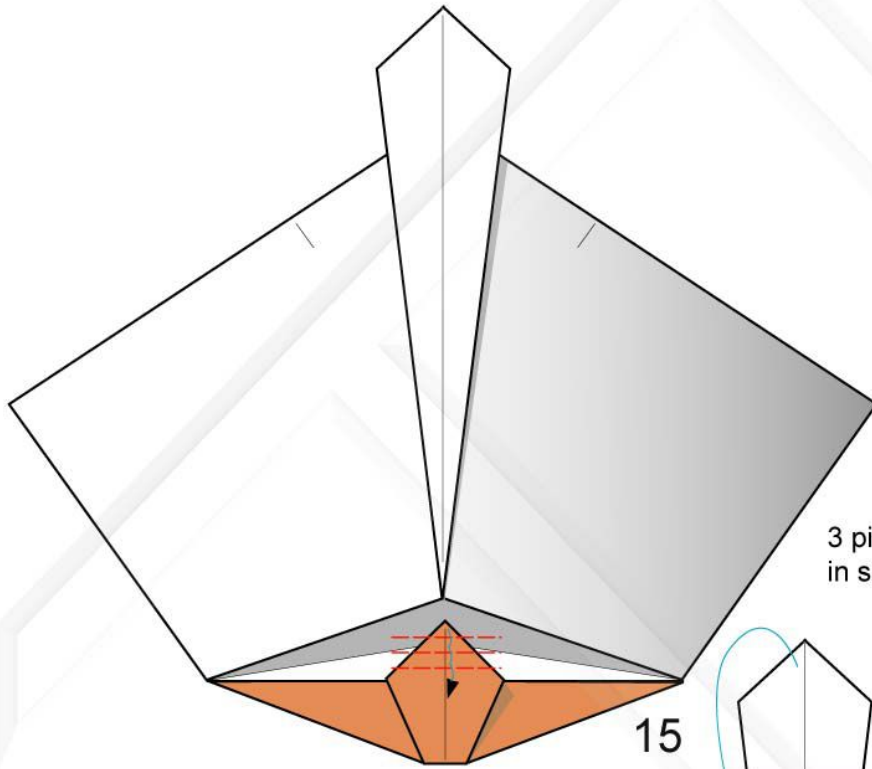

3 pieghe a valle e ruotate
in successione

15

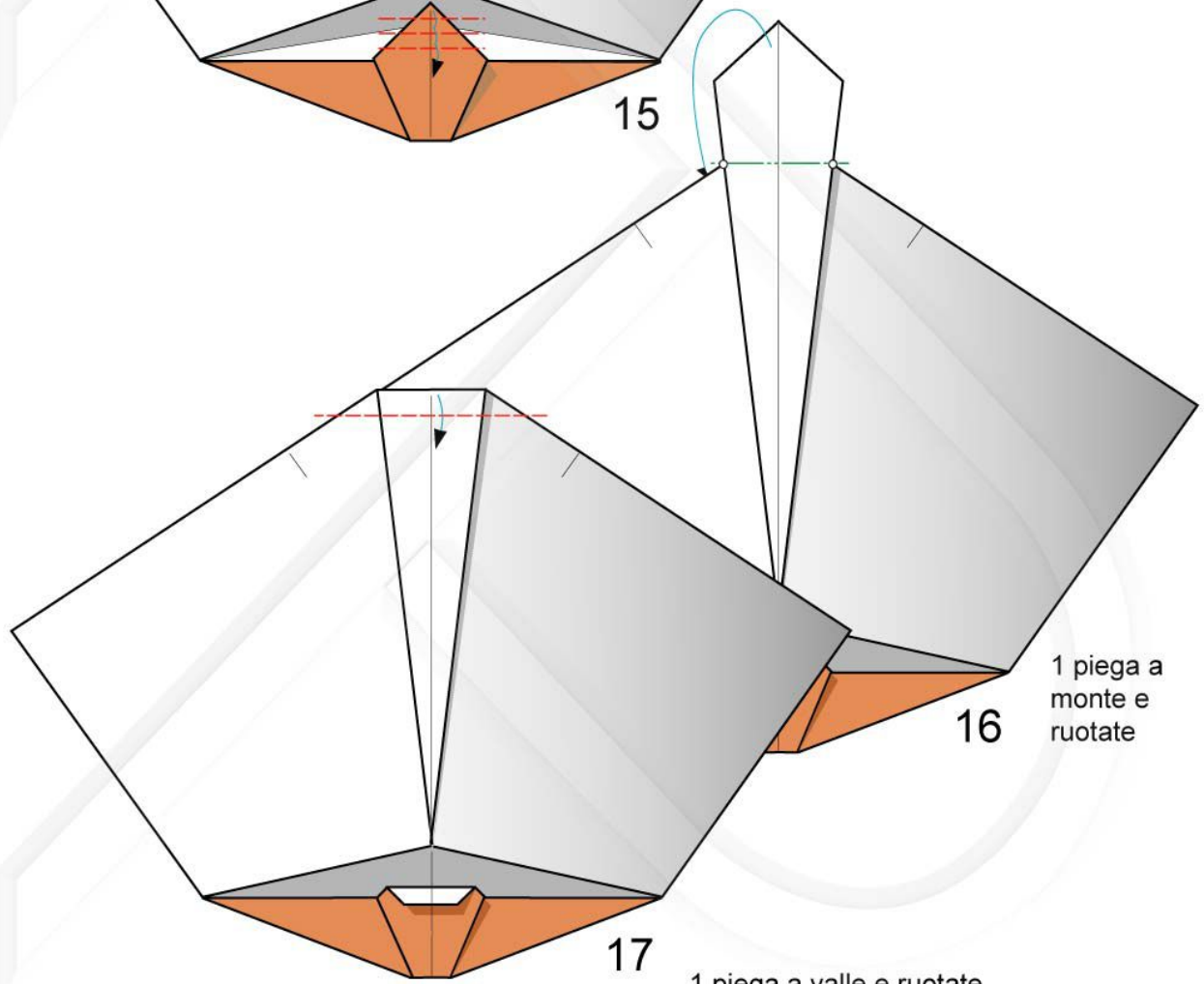

1 piega a
monte e
ruotate

16

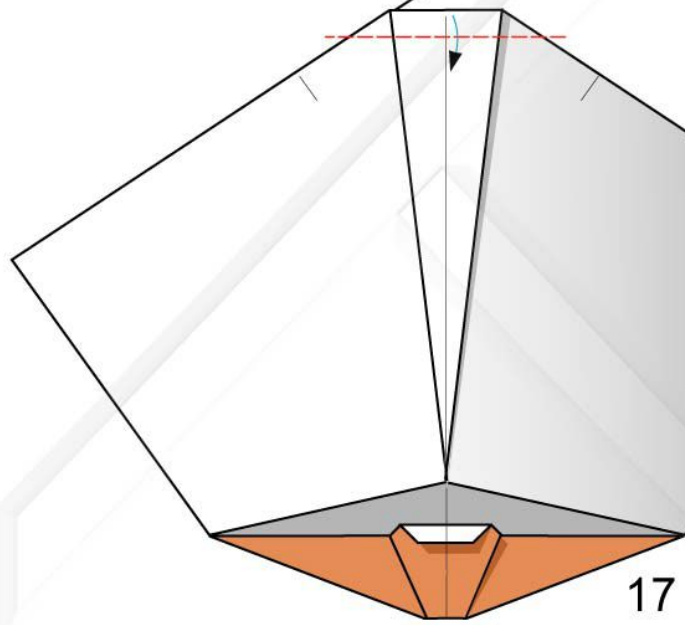

1 piega a valle e ruotate

17

48

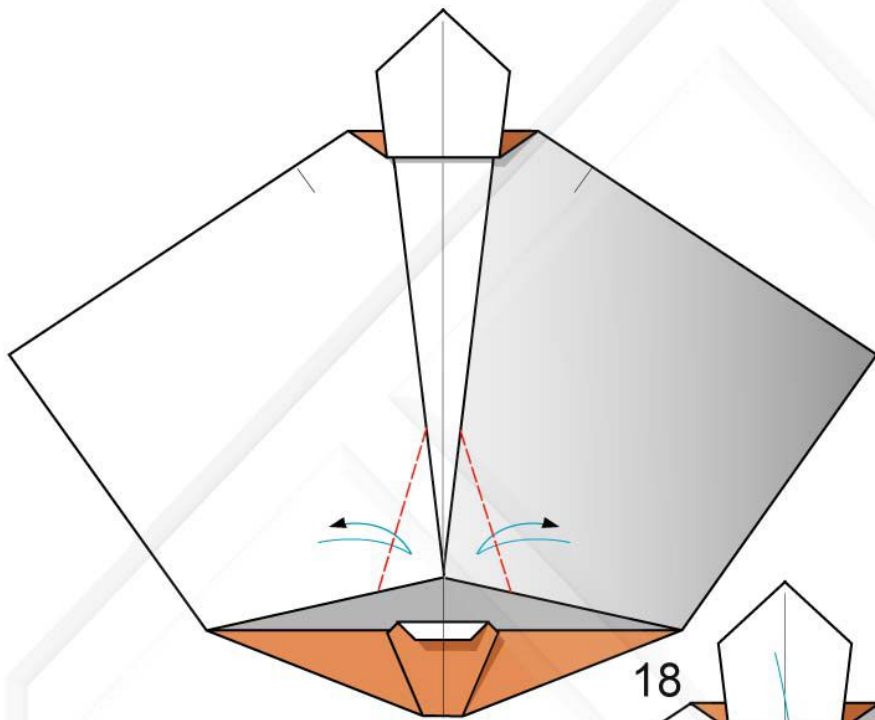

2 pieghe a valle

18

1 piega a valle e ruotate.

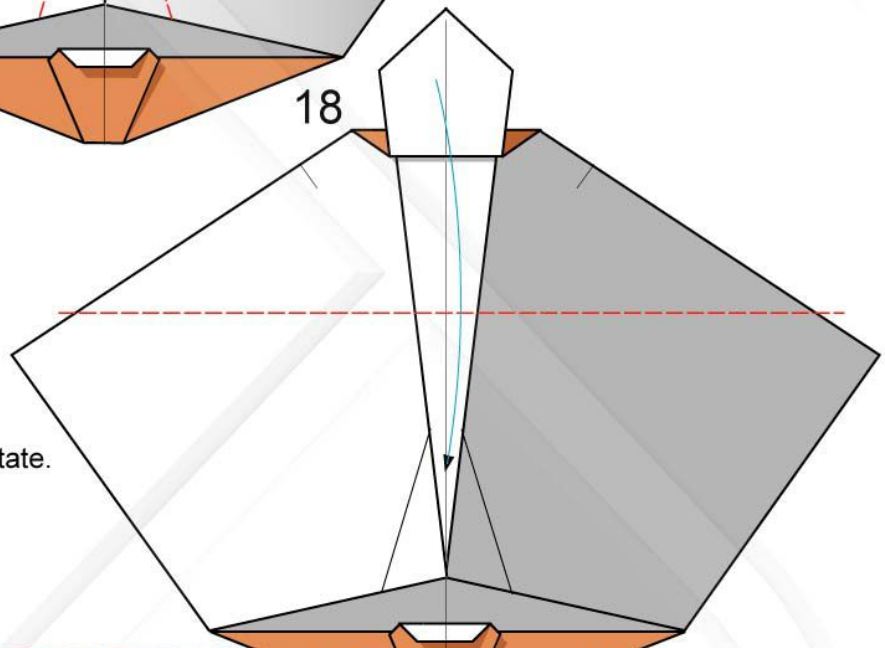

19

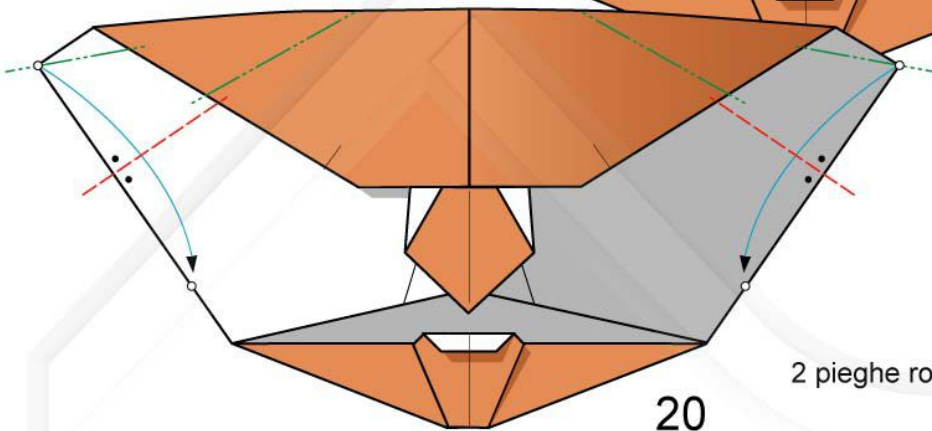

2 pieghe rovesce interne

20

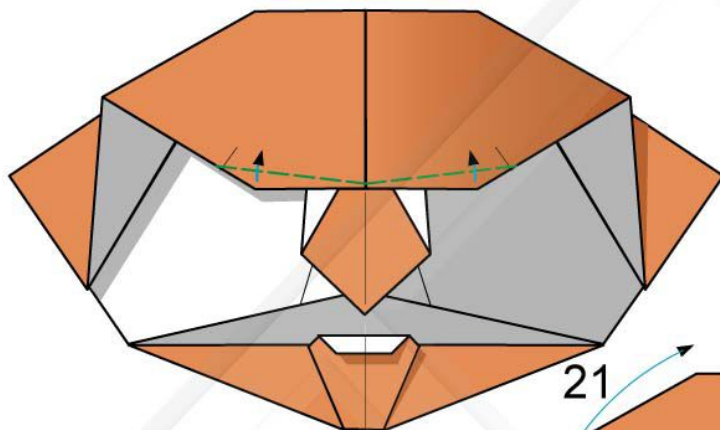

2 pieghe a valle e ruotate
per creare le sopracciglia

21

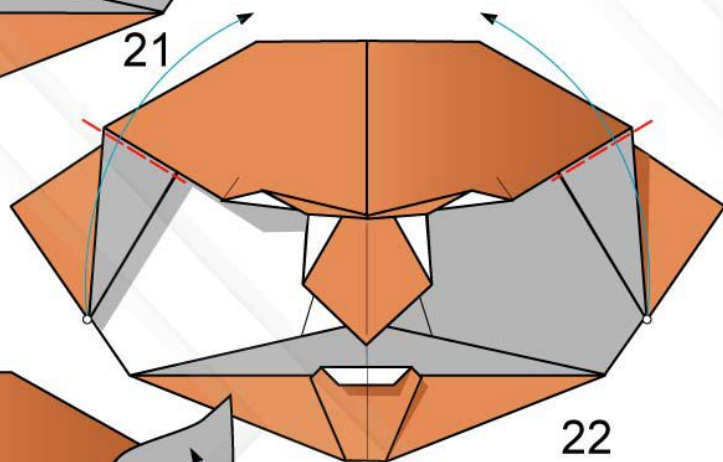

22

2 pieghe a valle e ruotate

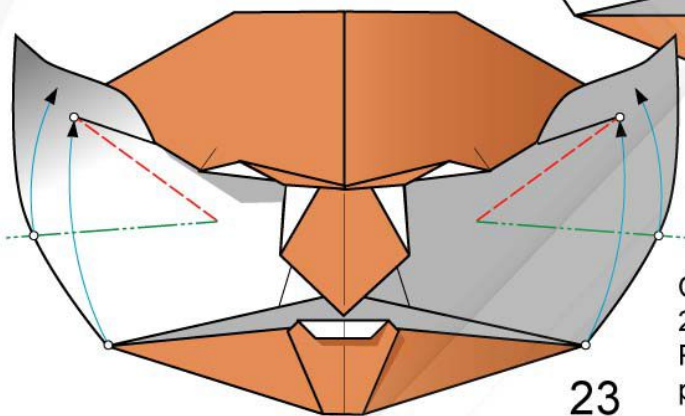

23

Chiudete la bocca del modello.
2 pieghe a valle, 2 a monte e ruotate 3D.
Prestate la massima attenzione nel
posizionamento e nella simmetria dei
punti di convergenza nelle guance

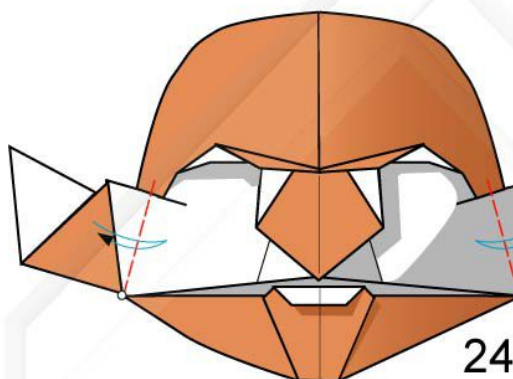

24

2 pieghe a valle

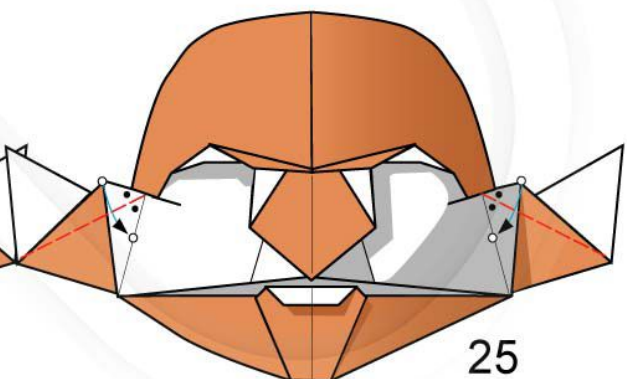

25

2 pieghe a valle bisettrici sulle
superfici in vista e ruotate

50

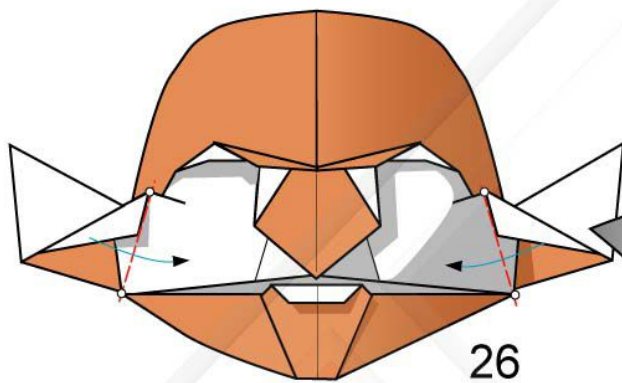

26

Ripiegando ruotate 3D
creando le orecchie

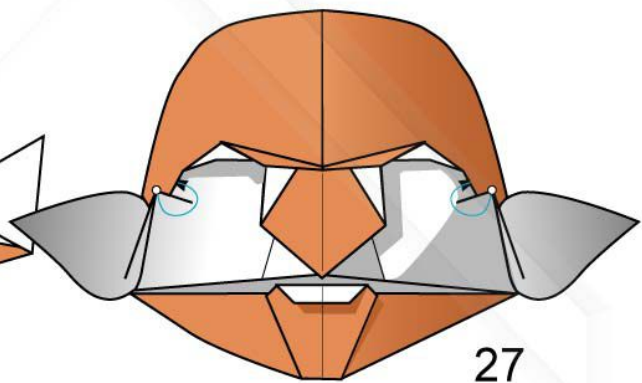

27

Intascate i vertici indicati

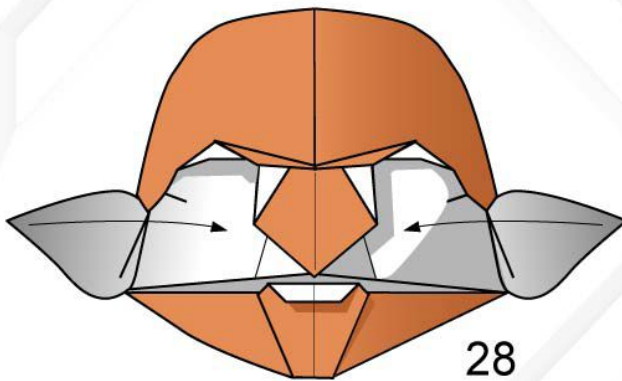

28

Chiudete le orecchie

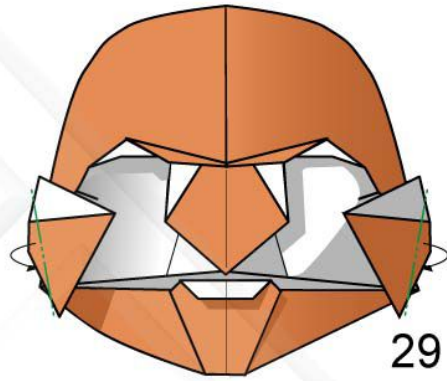

29

2 pieghe a monte

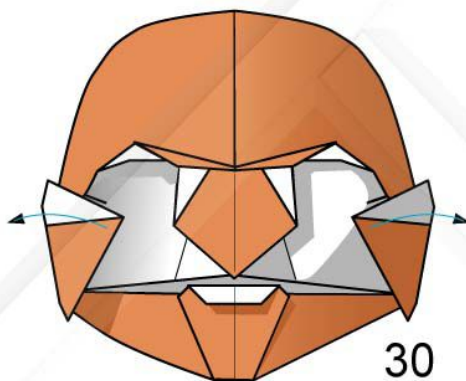

30

Riaprite le orecchie

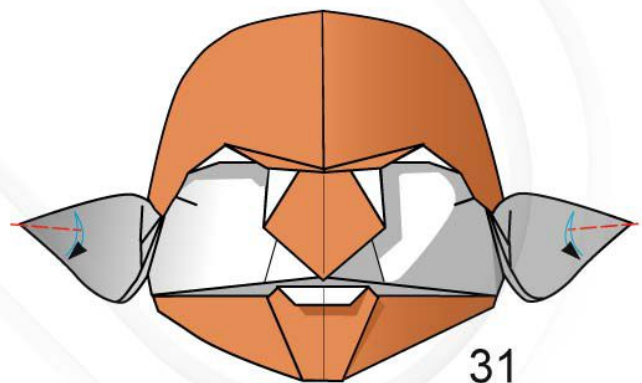

31

2 pieghe a valle e
modellate 3D le orecchie

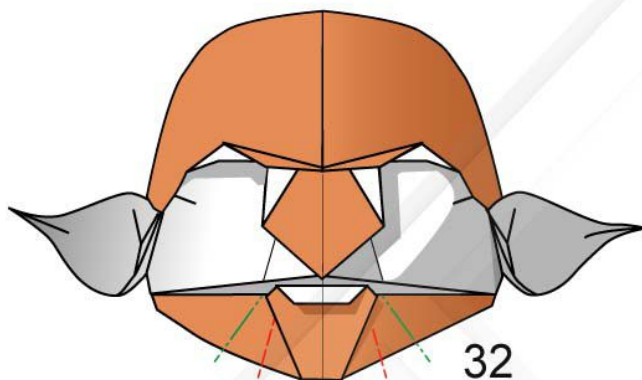

32

2 pieghe a valle e 2 a monte

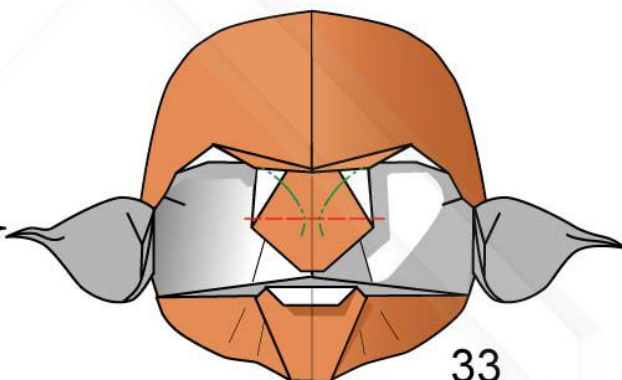

33

1 piega a valle e 2 a monte morbide per modellare 3D il naso

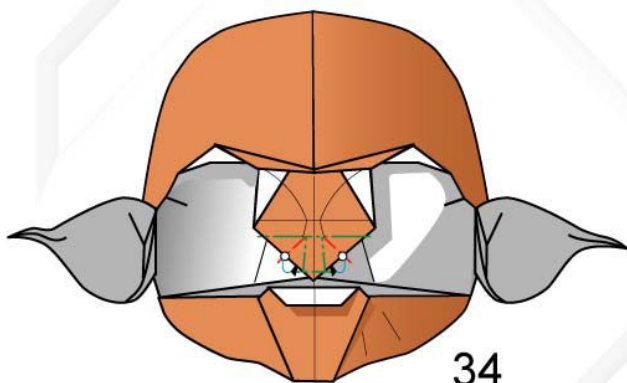

34

2 pieghe a valle e 3 a monte e modellate 3D il naso

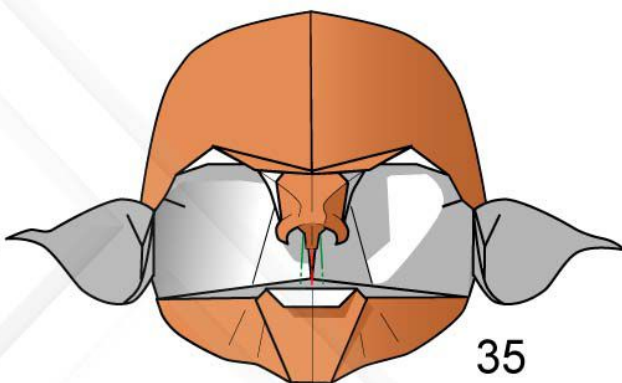

35

Mediante 3 piccole pieghe, 1 a monte e 2 a valle, modellate le labbra superiori

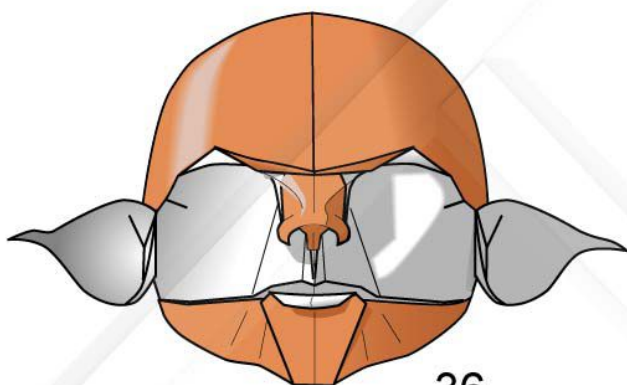

36

Maschera di Yoda ultimata

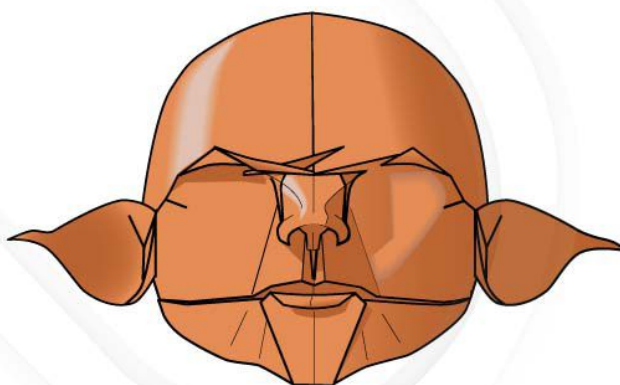

Maschera di Yoda ultimata realizzata con cartoncino monocolore

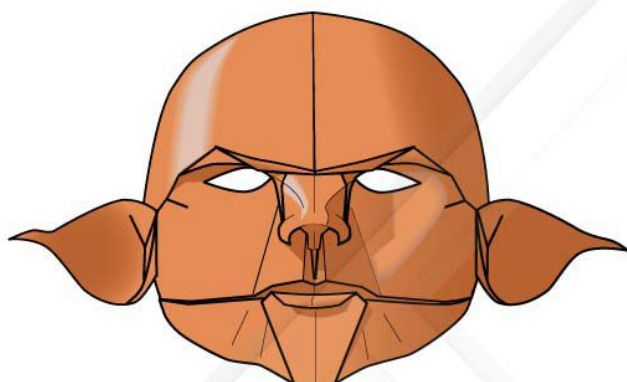

Maschera di Yoda
con occhi ritagliati

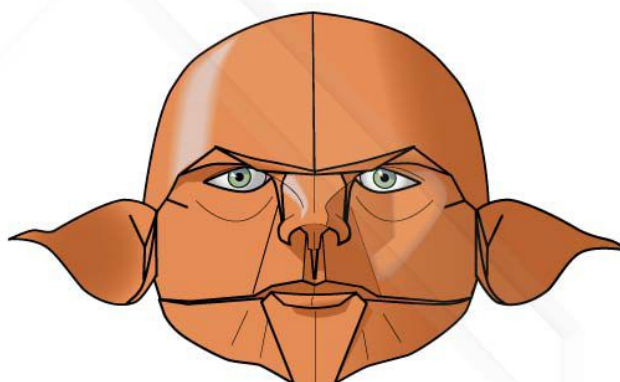

Maschera di Yoda con
occhi disegnati o incollati



VISTA DALL'ALTO



PROFILO



FRONTE



RETRO



VISTA DAL BASSO

CARONTE



Non c'è alcun dubbio sulla
sembianza demoniaca di
questa maschera dall'aspetto
fiero e malvagio.

Partite da un foglio di
cartoncino quadrato
monocolore di 42 cm di lato

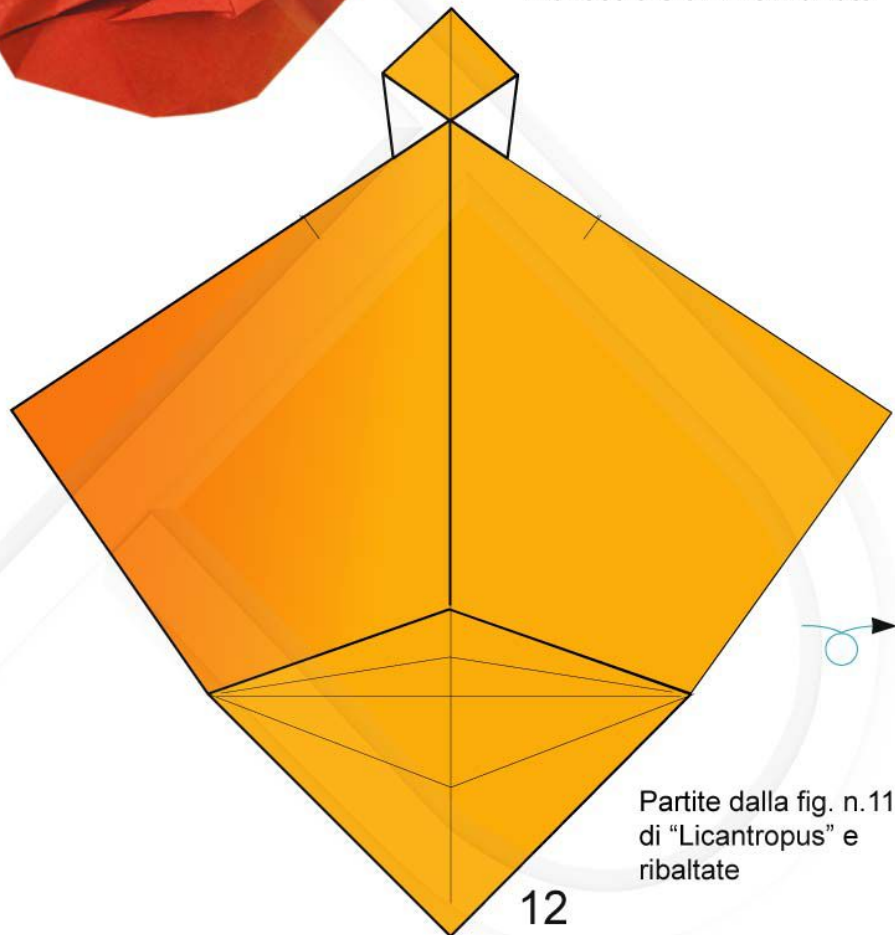

Partite dalla fig. n.11
di "Licantropus" e
ribaltate

12

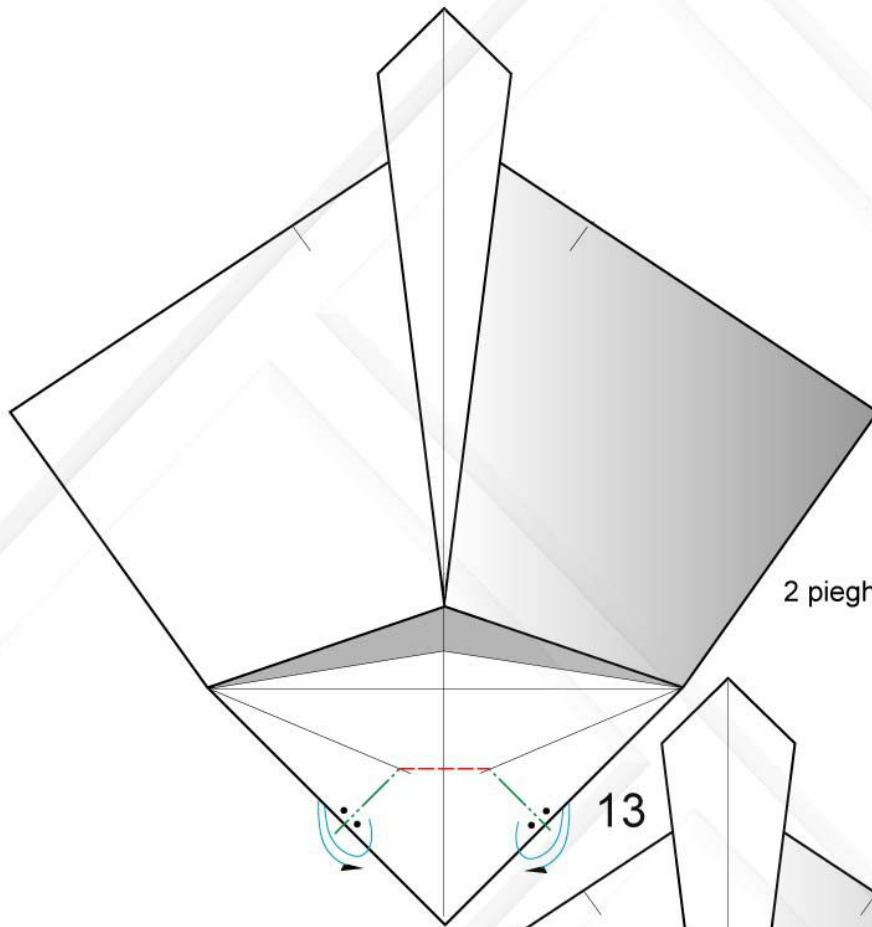

2 pieghe a valle ed 1 a monte

13

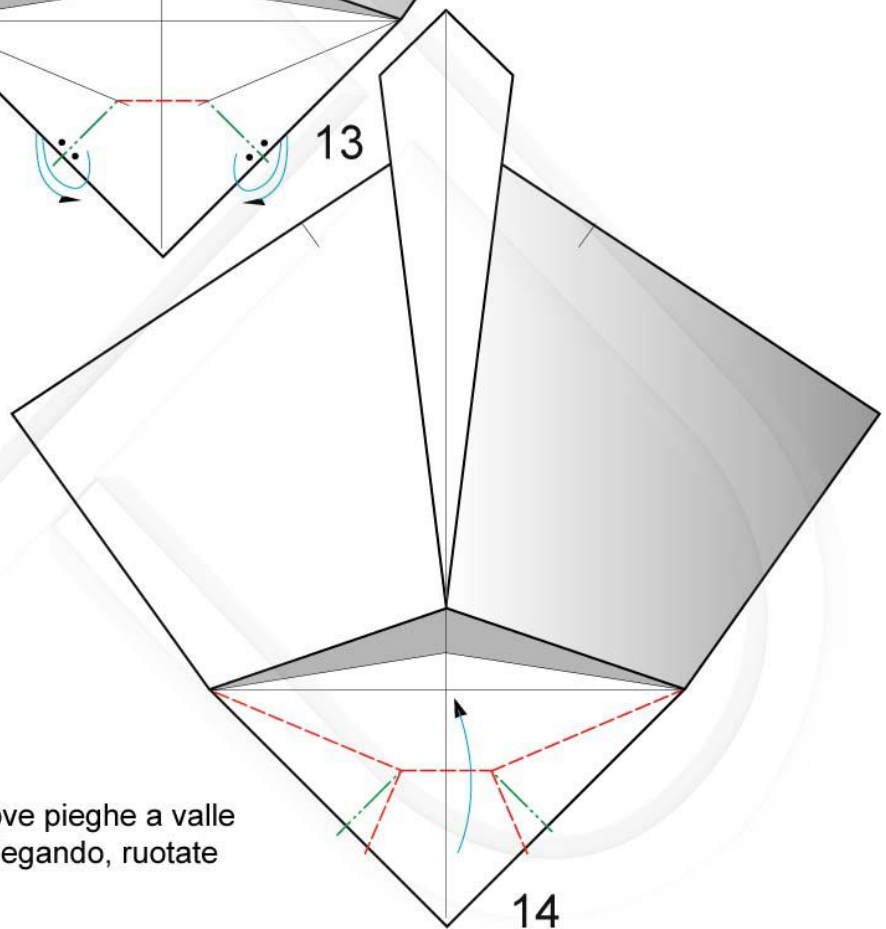

2 nuove pieghe a valle
e, ripiegando, ruotate

14

55

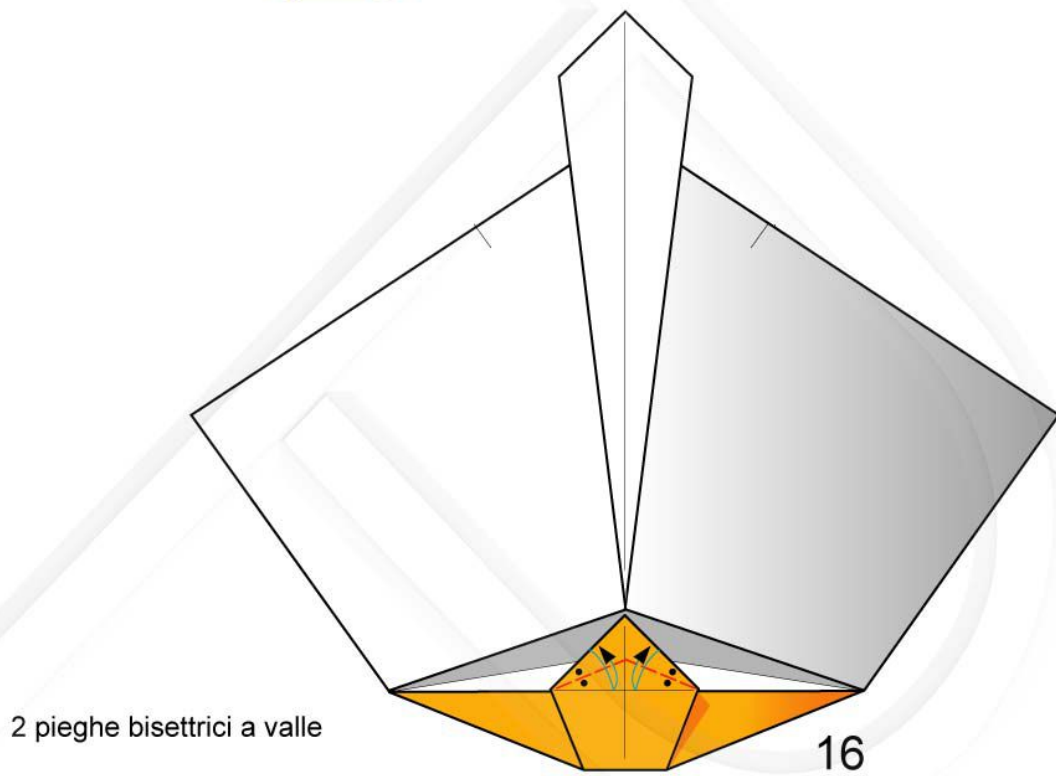
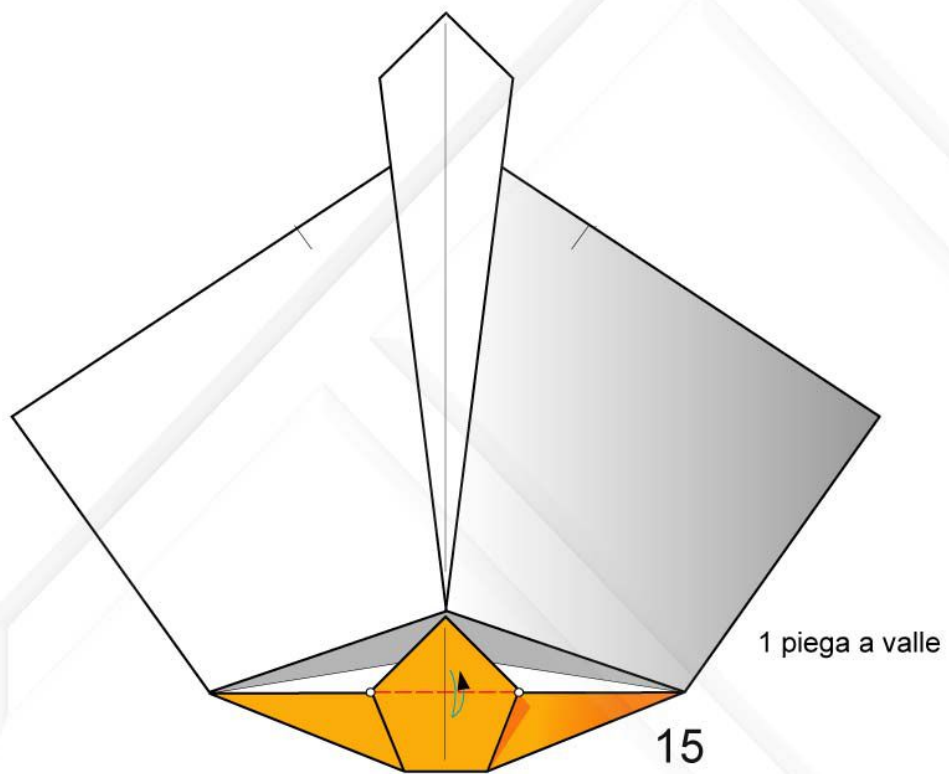

56

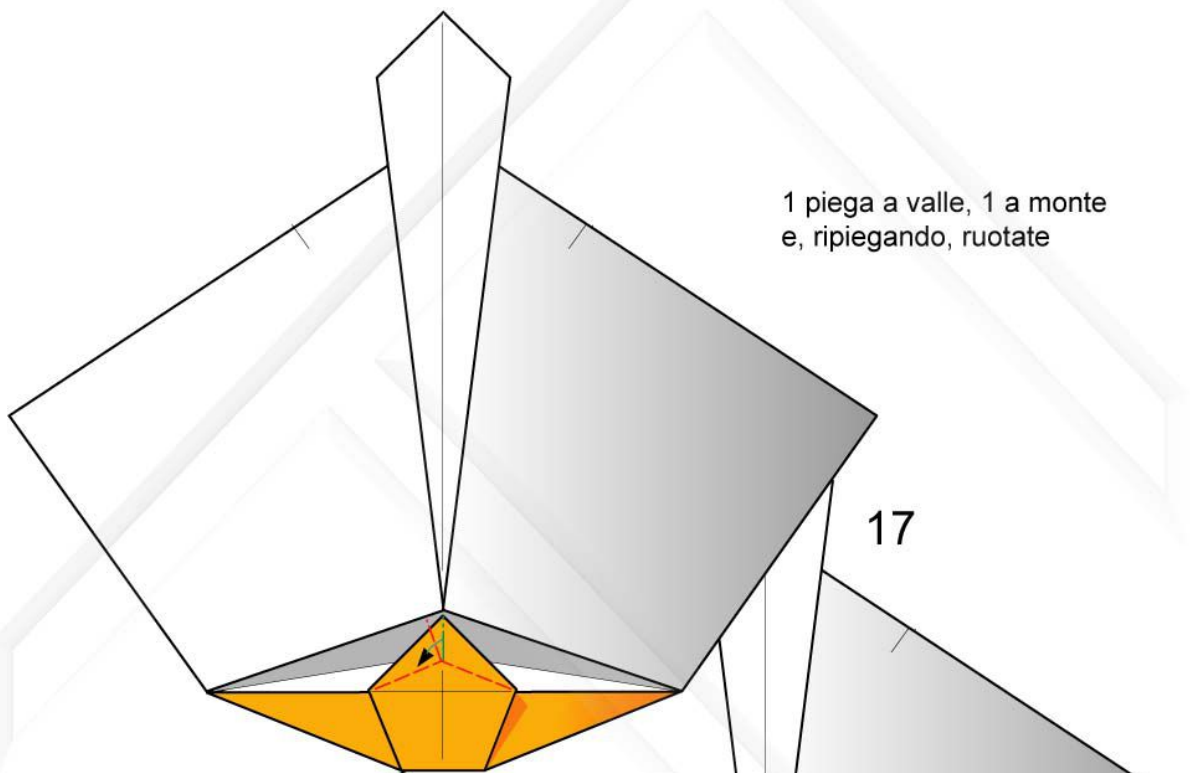

1 piega a valle, 1 a monte
e, ripiegando, ruotate

17

mediante 1 piega a
valle interna ruotate
il vertice inferiore
bloccando il labbro

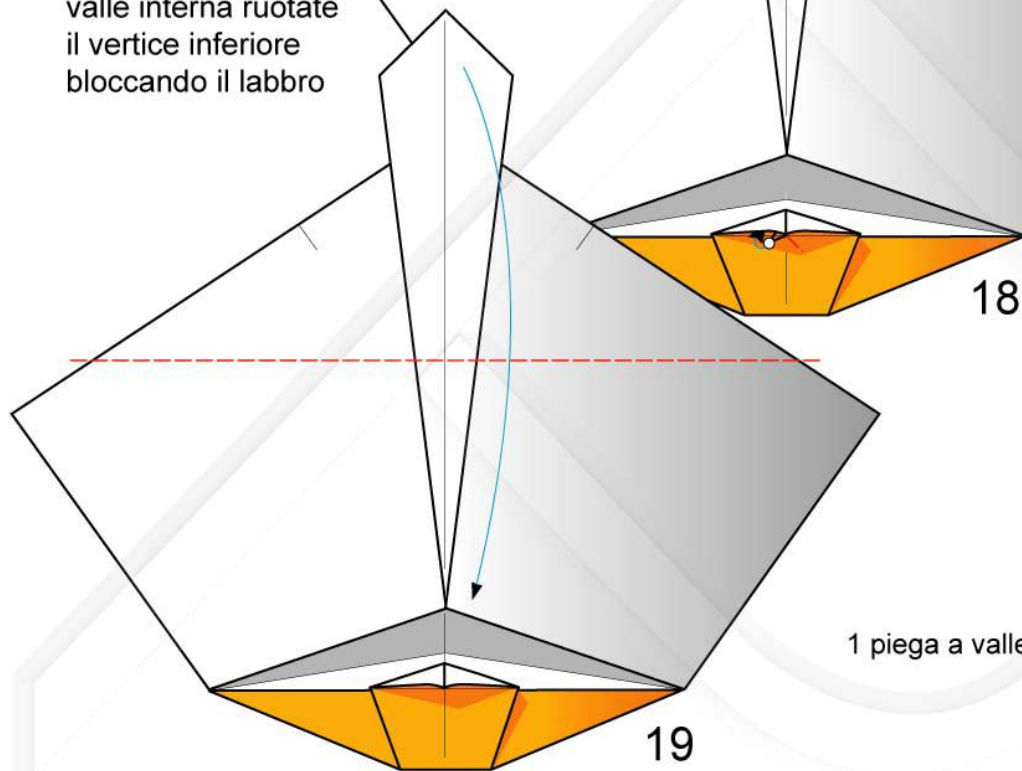

18

1 piega a valle e ruotate

19

57

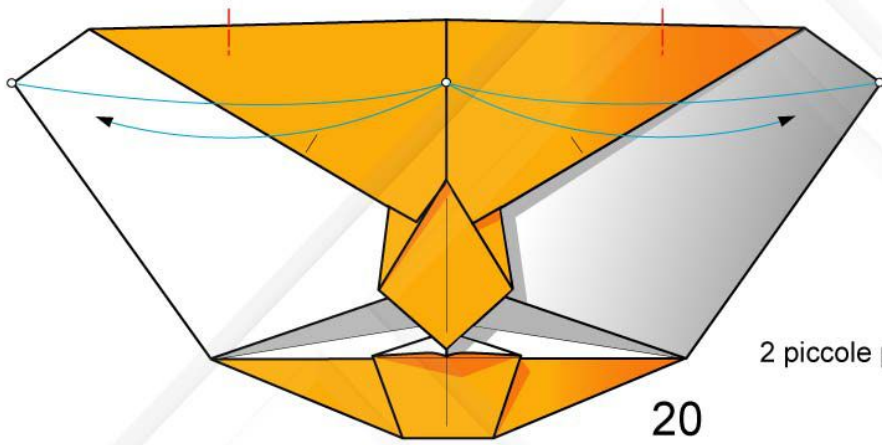

2 piccole pieghe a valle

20

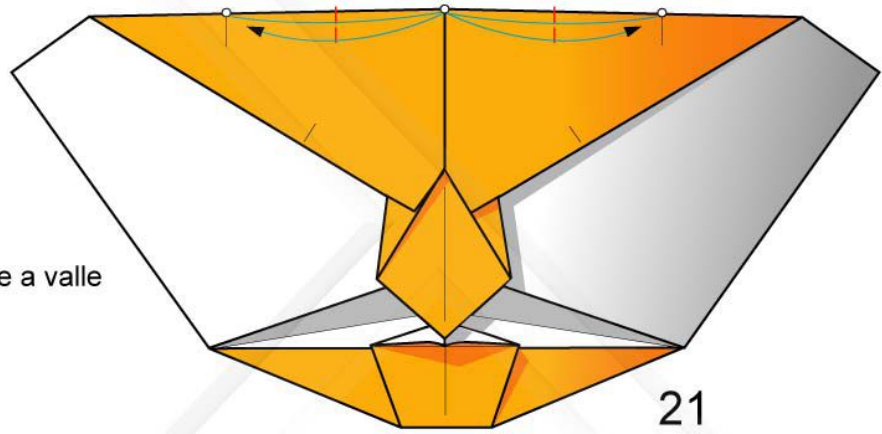

2 piccole pieghe a valle

21

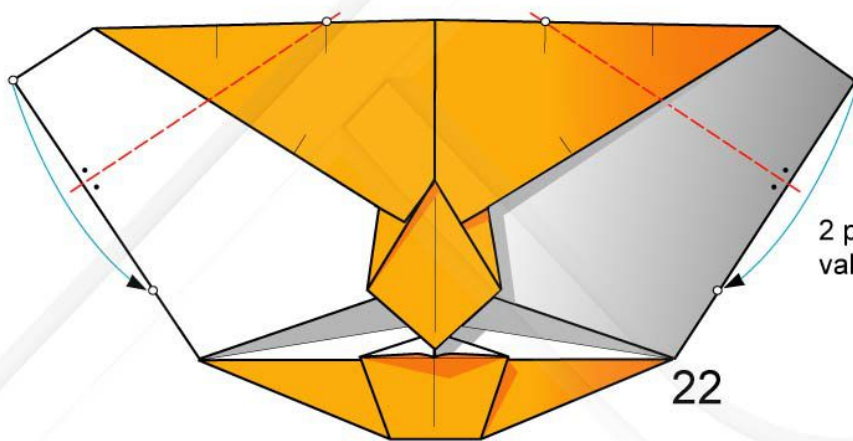

2 pieghe bisettrici a valle e ruotate

22

58

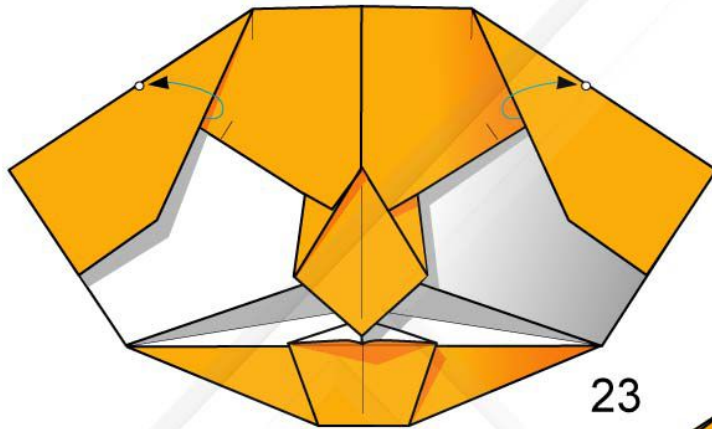

Estraete

23

2 piccole pieghe bisettrici a valle solo sulla sup. in vista

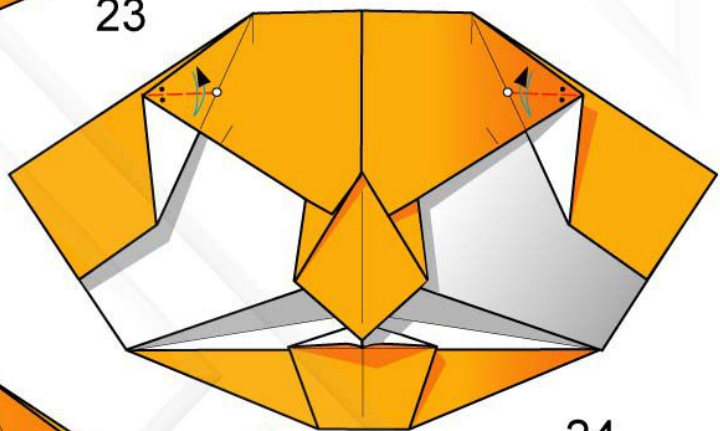

24

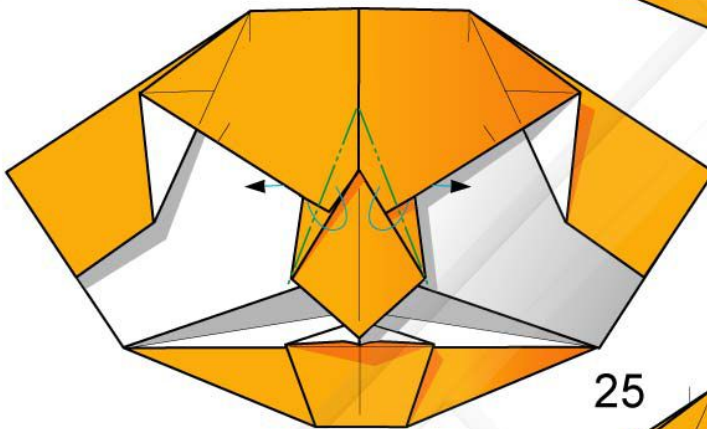

2 pieghe rovesce interne

25

2 pieghe a valle,
4 a monte e ruotate

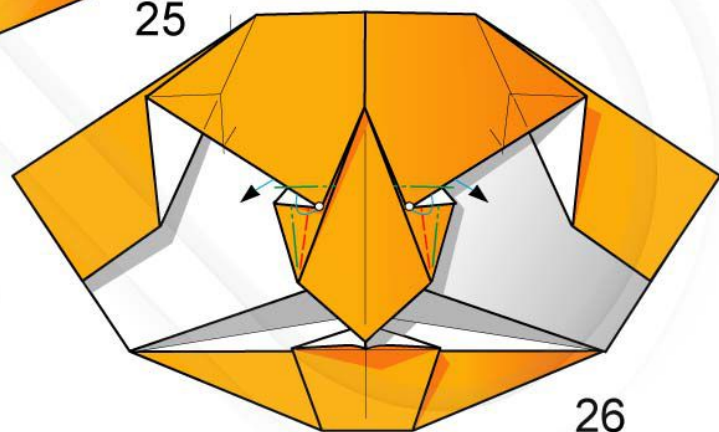

26

59

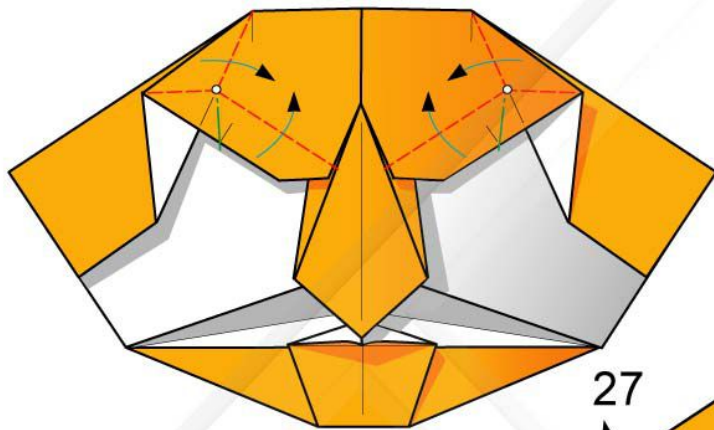

2 pieghe a valle, 2 a monte
e ripiegando ruotate

27

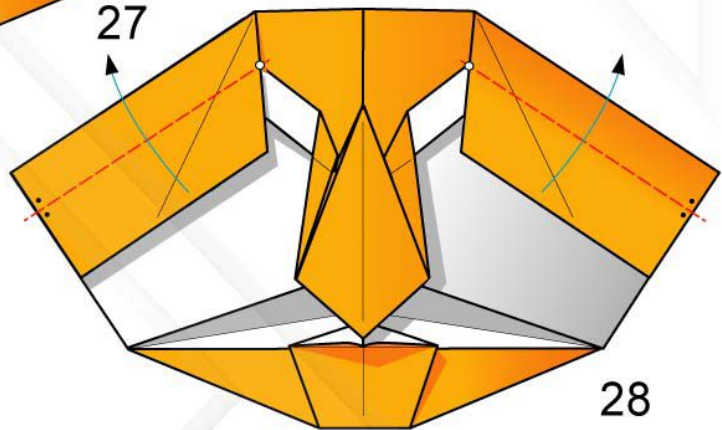

2 pieghe a valle e ruotate

28



2 piccole pieghe a valle

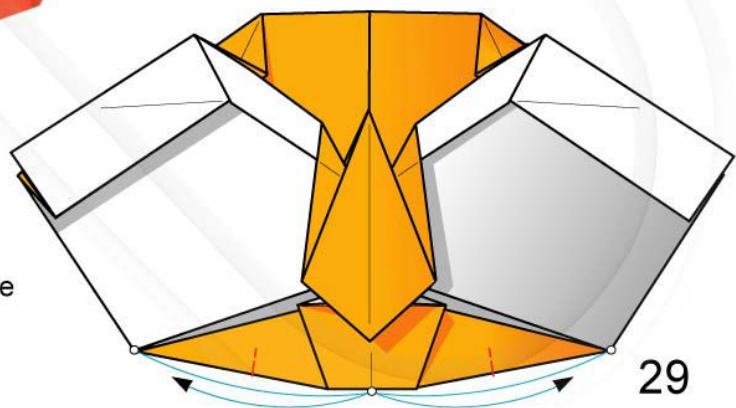

29

60

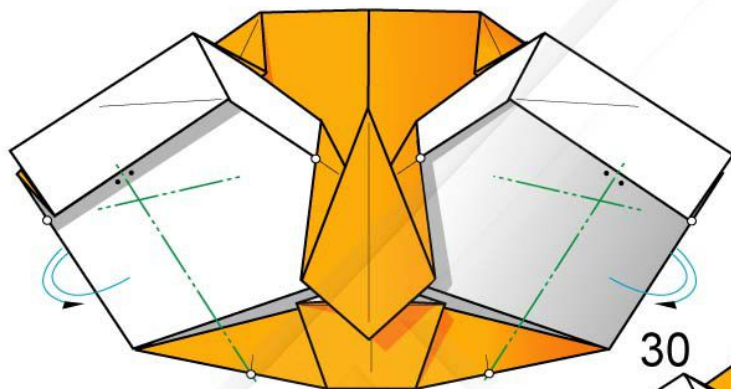

Chiudete la bocca del modello.
4 pieghe a monte

30

6 pieghe a valle e ripiegando a monte
ruotate 3D.
Prestate la massima attenzione nel
posizionamento e nella simmetria dei
punti di convergenza nelle guance

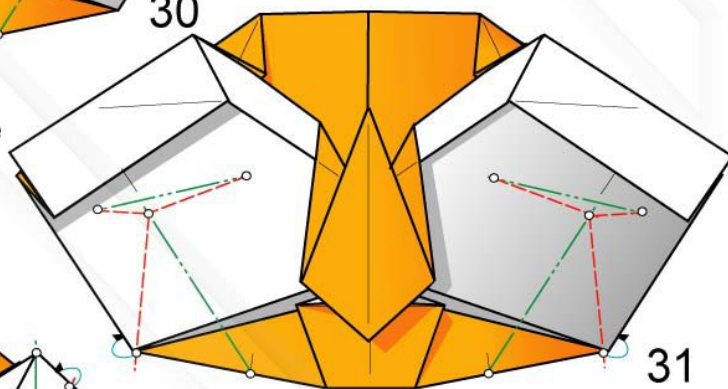

31

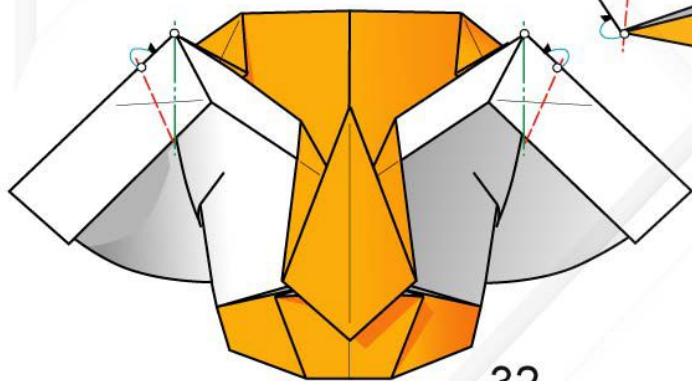

32

2 pieghe a valle, 2 pieghe
a monte e ruotate a "z"

1 piega a monte e modellate 3D il mento

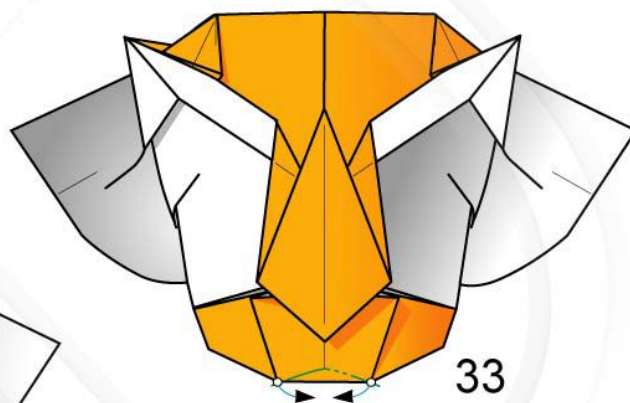

33

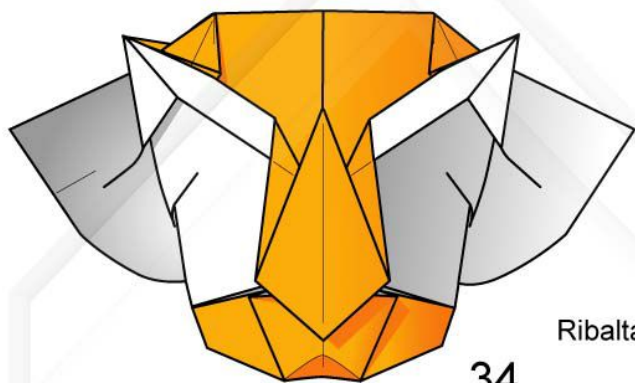

34

Ribaltate

61

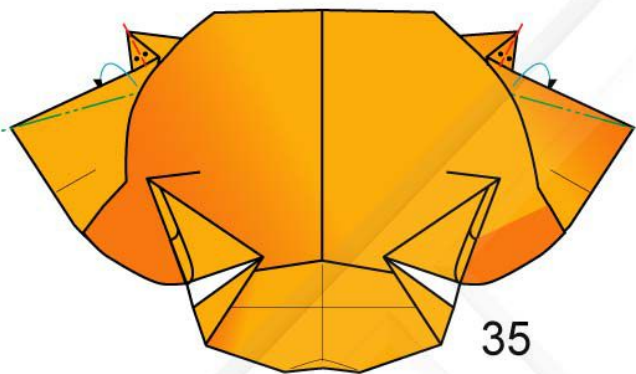

35

2 pieghe a monte, 2 piccole bisettrici a valle e ruotate

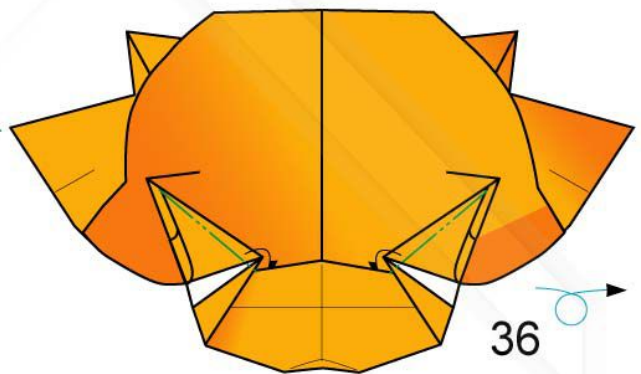

36

2 pieghe a monte, intascate bloccando il modello e ribaltate

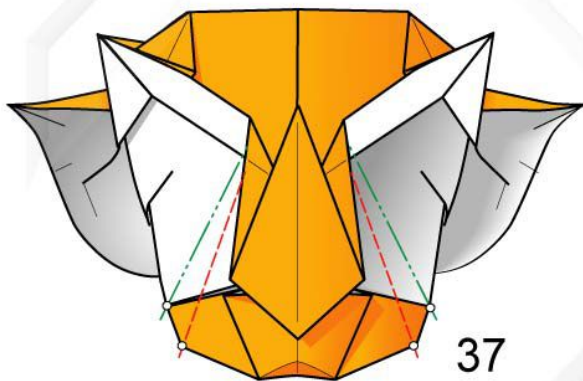

37

2 pieghe a valle e 2 a monte

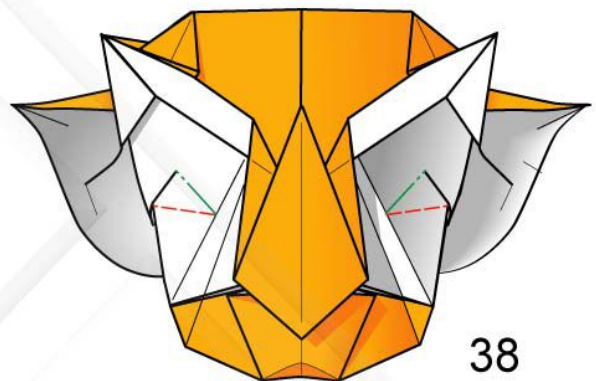

38

2 pieghe a valle e 2 a monte

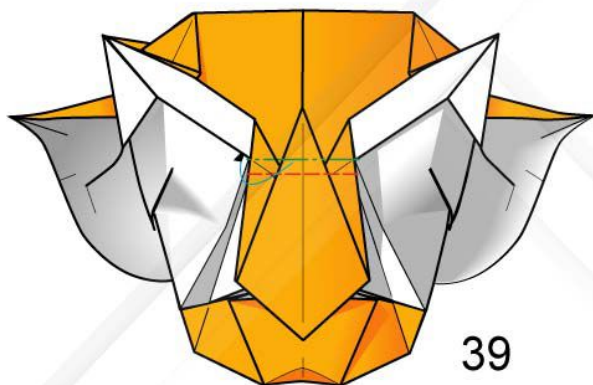

39

1 piega a valle, 1 a monte e ruotate a "z"

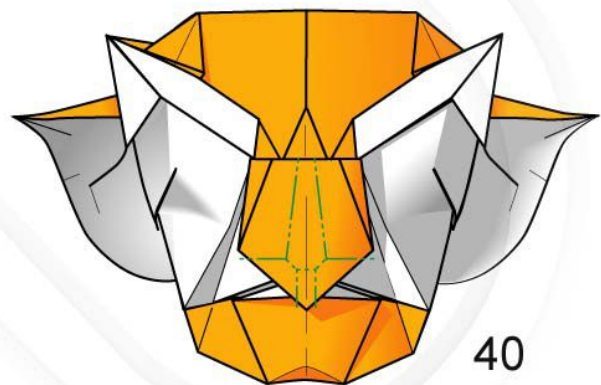

40

2 pieghe a monte verticali morbide e 7 piccole

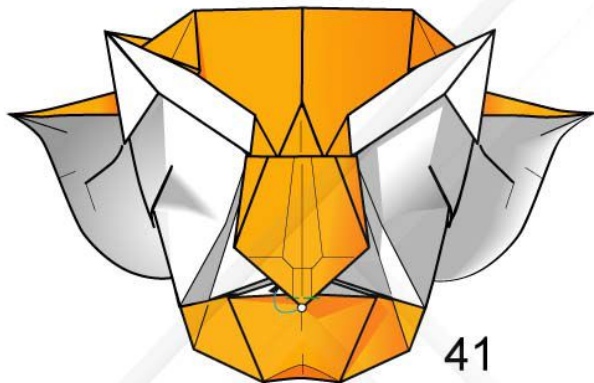

41
1 piccola piega a monte
e ruotate all' indietro

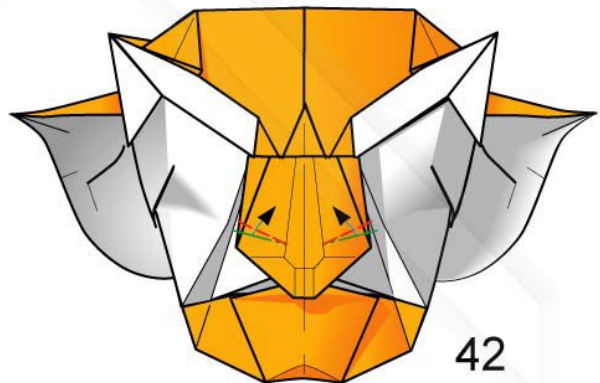

42
2 pieghe a valle, 2 a
monte e ruotate a"z"

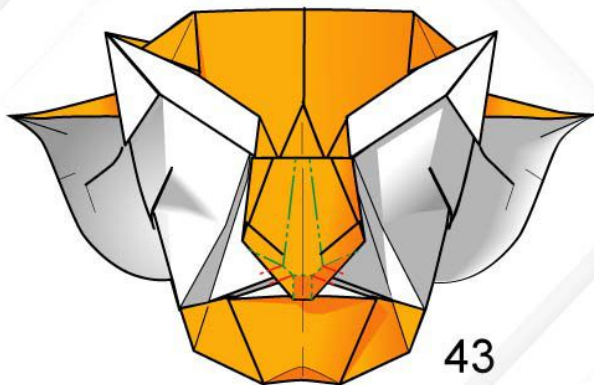

43
4 piccole pieghe a valle e
ripiegando a monte, modellate 3D

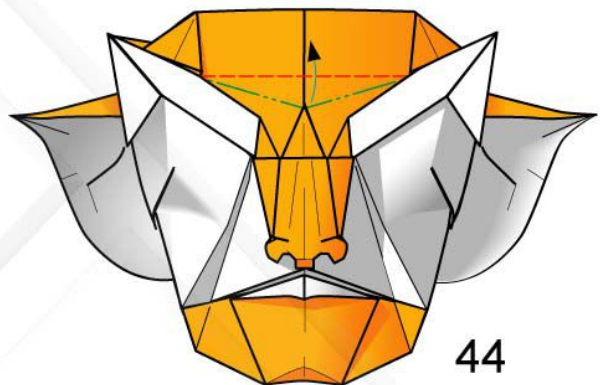

44
1 piega a valle, 2 a
monte e sollevate 3D

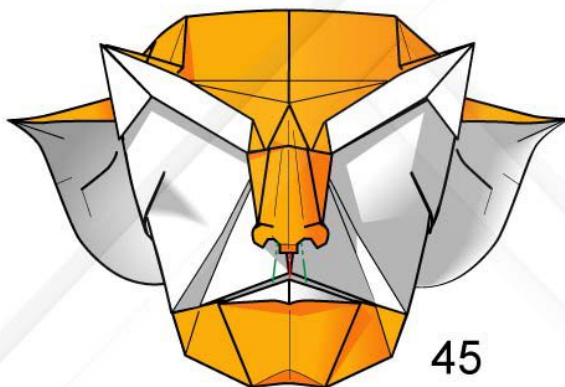

45
Maschera di Caronte ultimata

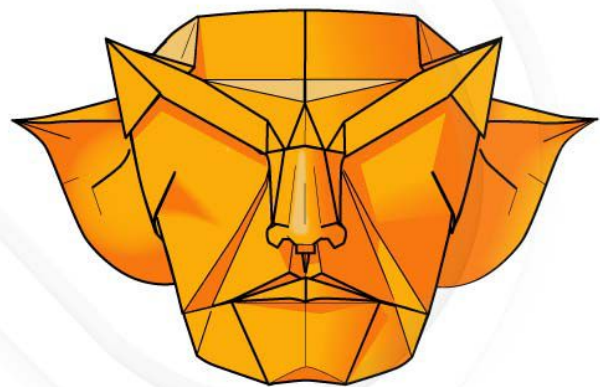

Maschera di Caronte ultimata realizzata
con cartoncino monocoloro



Maschera di Caronte
con occhi ritagliati

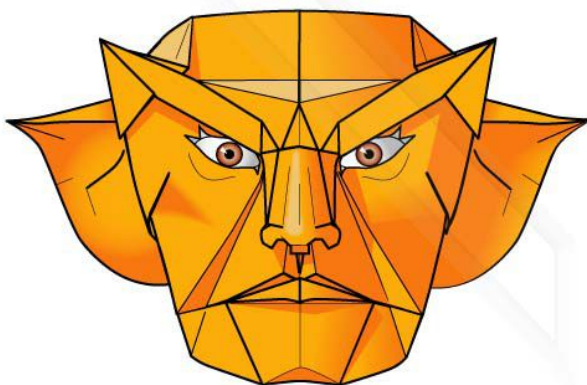

Maschera di Caronte con
occhi disegnati o incollati



VISTA DALL'ALTO



PROFILO



FRONTE



RETRO



VISTA DAL BASSO

SKRRR



Il rettiliano Skrr è l'abitante di un mondo dal nome impronunciabile distante molti anni luce dal nostro, dove sono stati i rettili ad evolversi in una specie intelligente...

Adoperate un foglio di cartoncino quadrato mocolore di 42 cm di lato

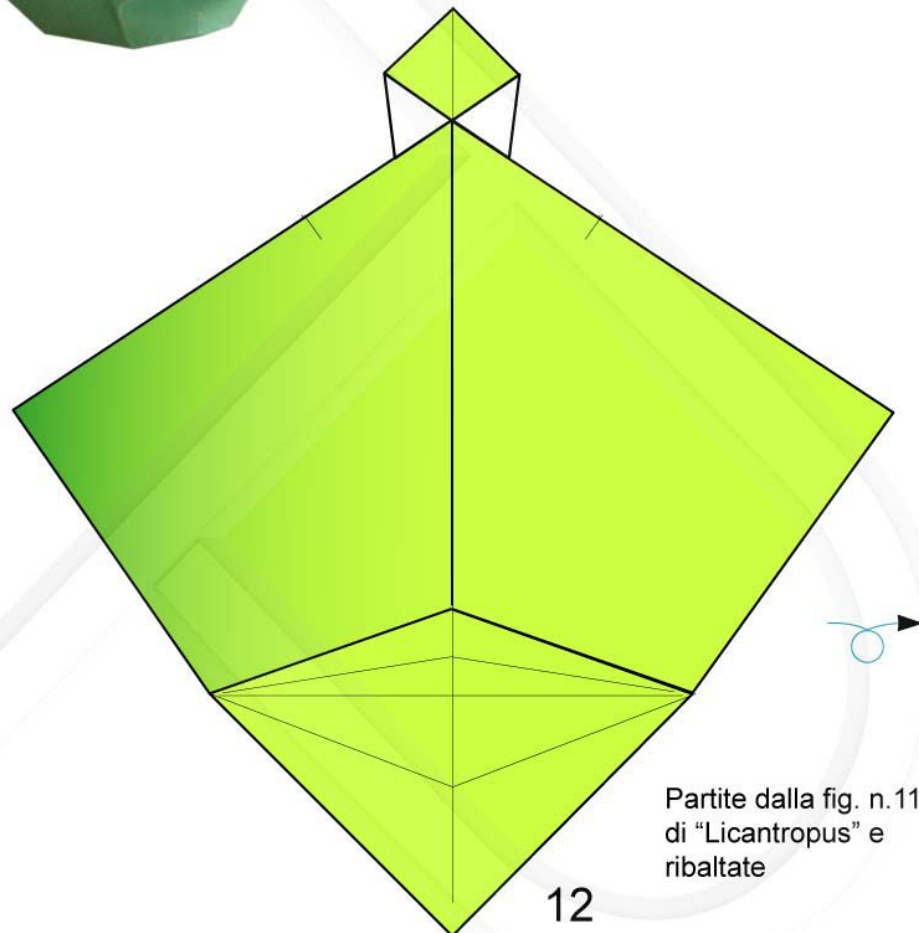

Partite dalla fig. n. 11 di "Licantropus" e ribaltate

12

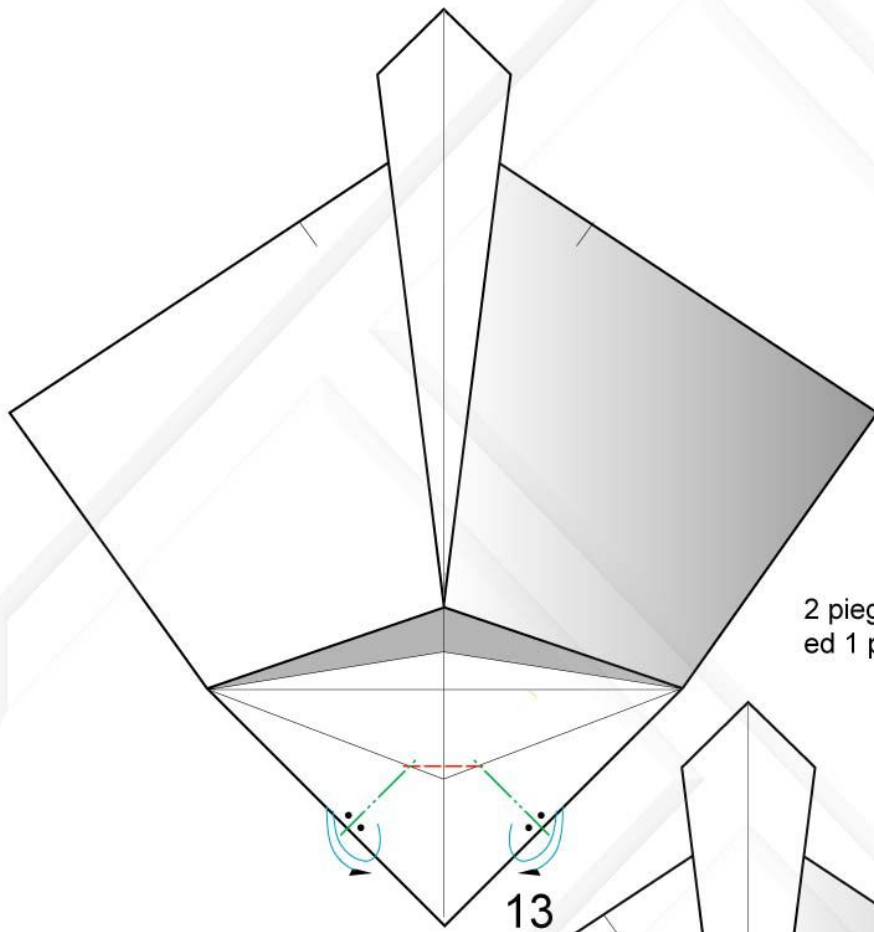

2 pieghe bisettrici a monte
ed 1 piega a valle

13

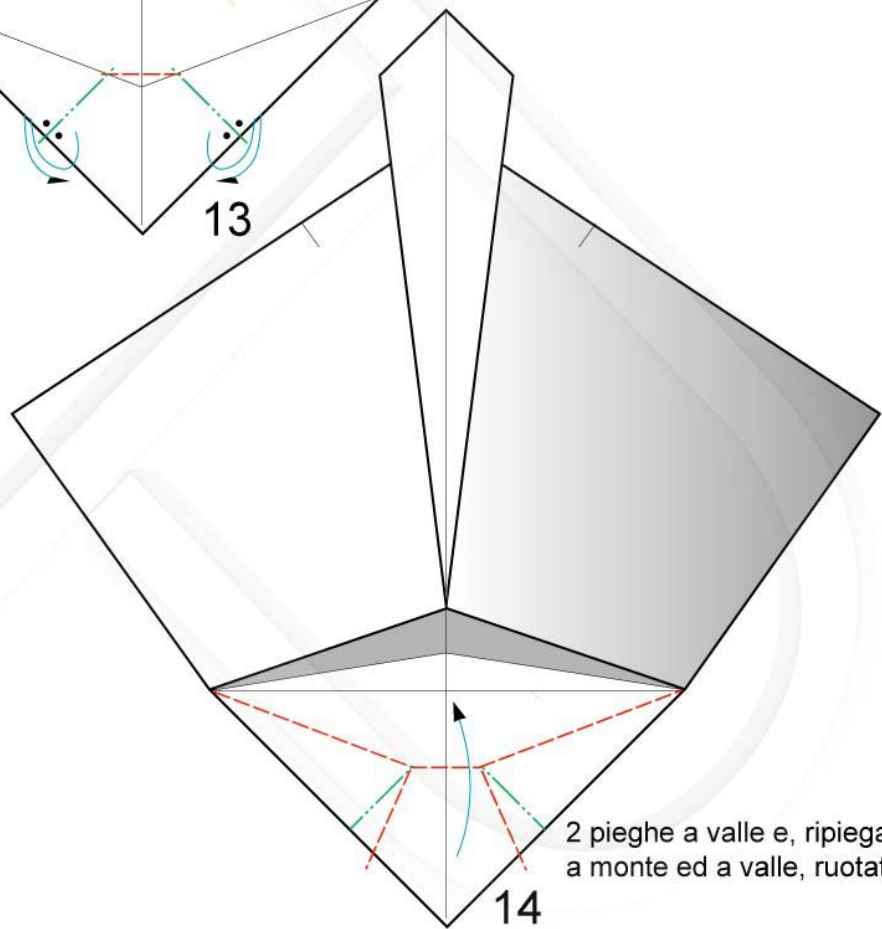

2 pieghe a valle e, ripiegando
a monte ed a valle, ruotate

14

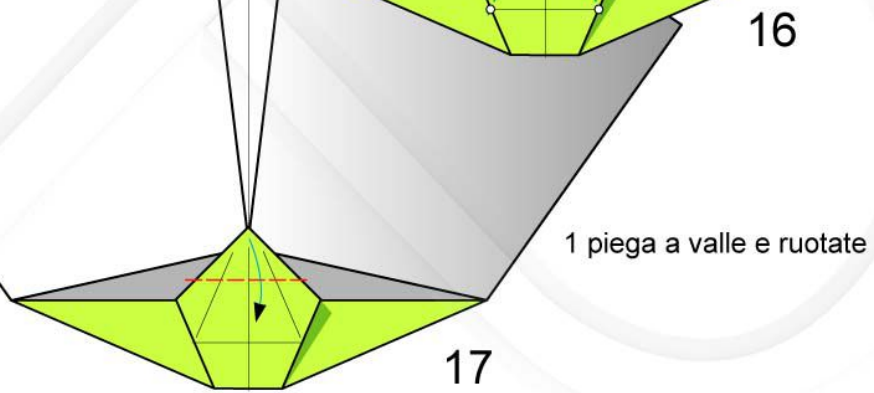
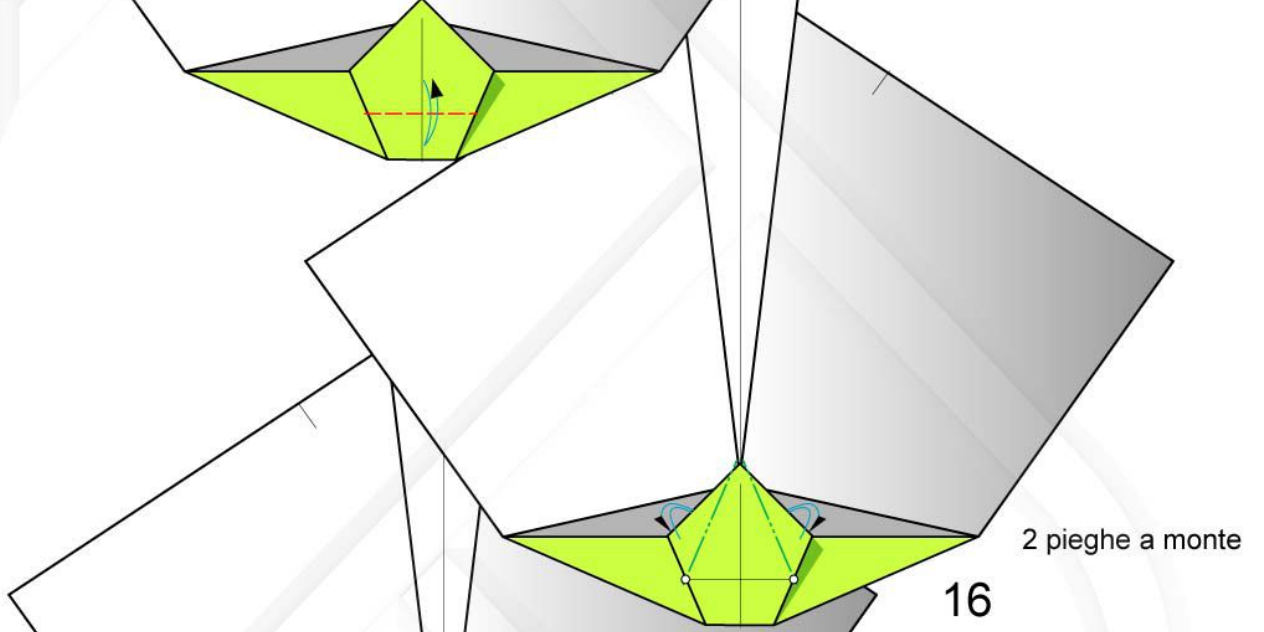
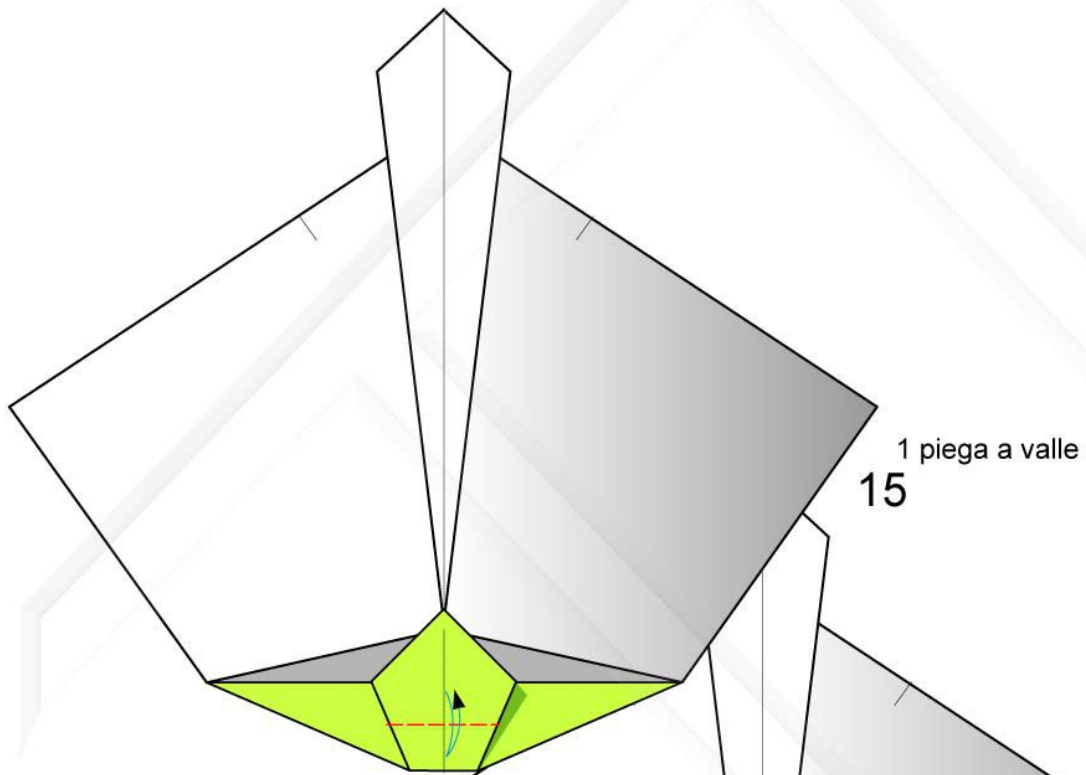

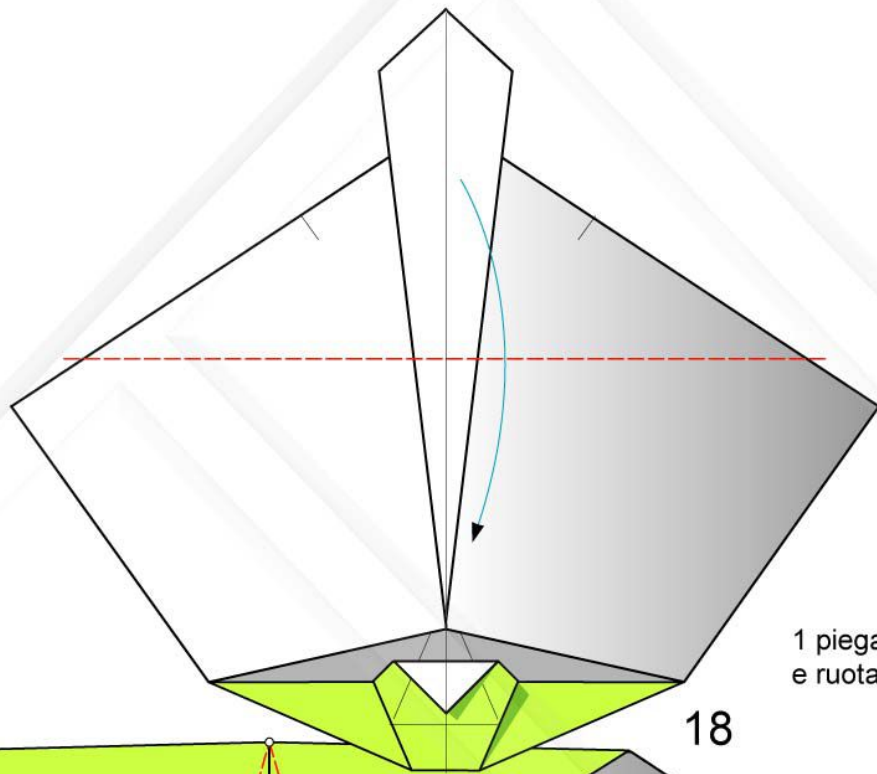

1 piega a valle
e ruotate

18

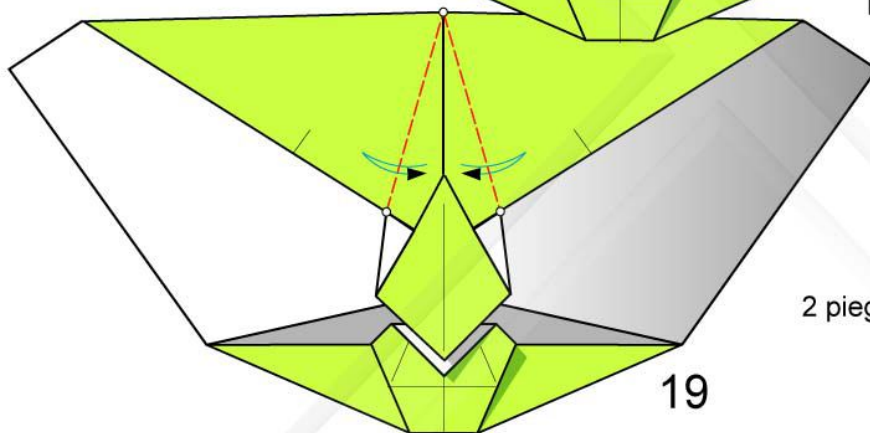

2 pieghe a valle

19

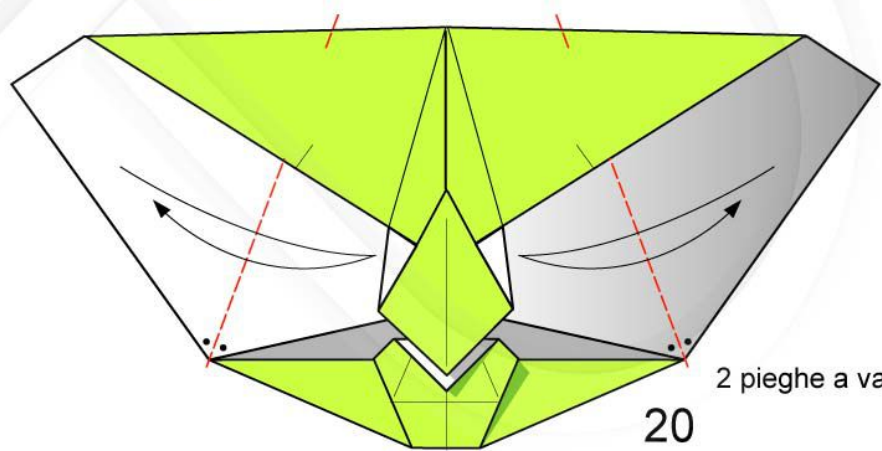

2 pieghe a valle

20

68

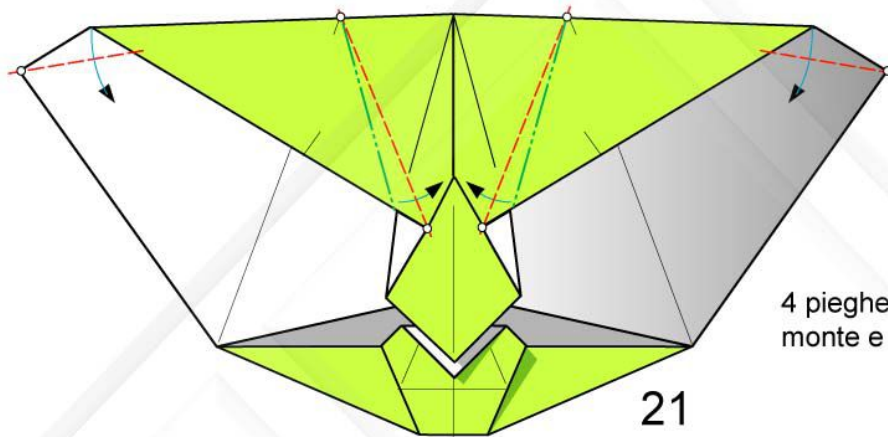

4 pieghe a valle, 2 a monte e ruotate 3D

21

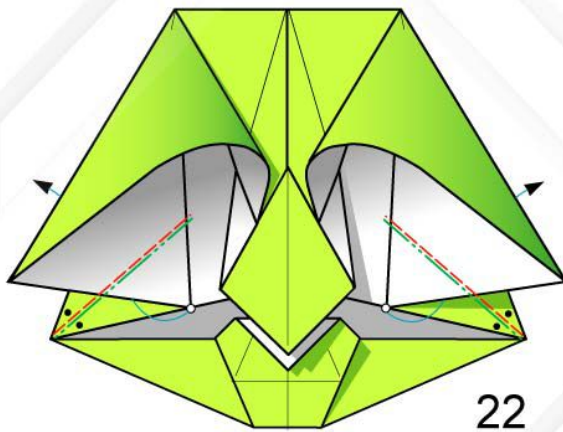

2 pieghe rovesce interne

22

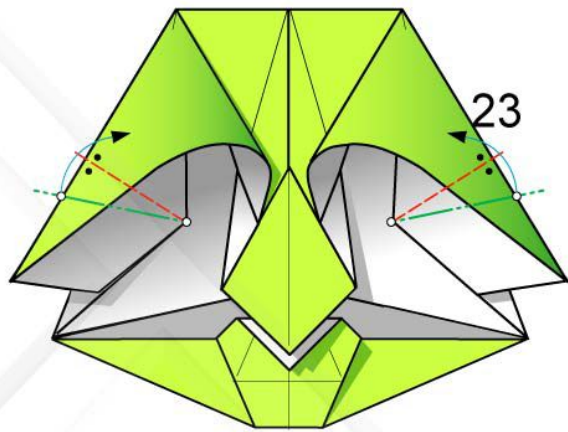

2 pieghe a valle, 2 pieghe a monte e ruotate

23

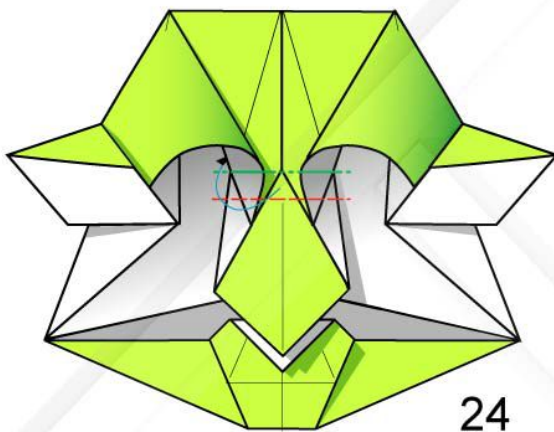

1 piega a valle, 1 a monte e ruotate piegando a "z"

24

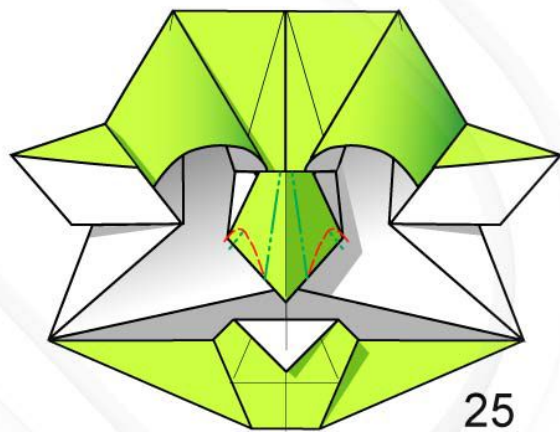

2 pieghe a valle, 4 pieghe a monte morbide e ruotate 3D

25

Disegni ingranditi 120 %



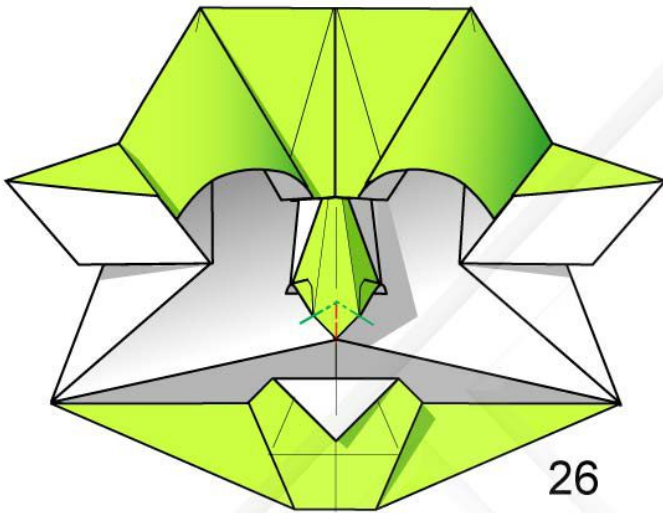

26

2 pieghe a monte, 1 a valle e ruotate 3D

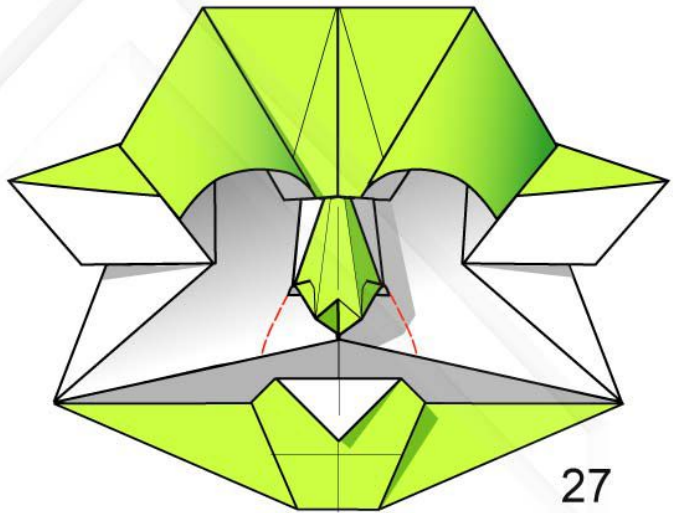

27

2 pieghe a valle

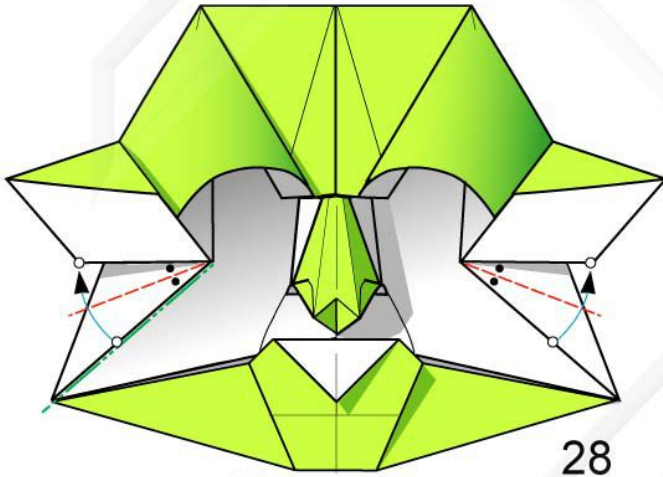

28

Chiudete la bocca.
2 pieghe bisettrici a valle,
2 a monte e ruotate 3D

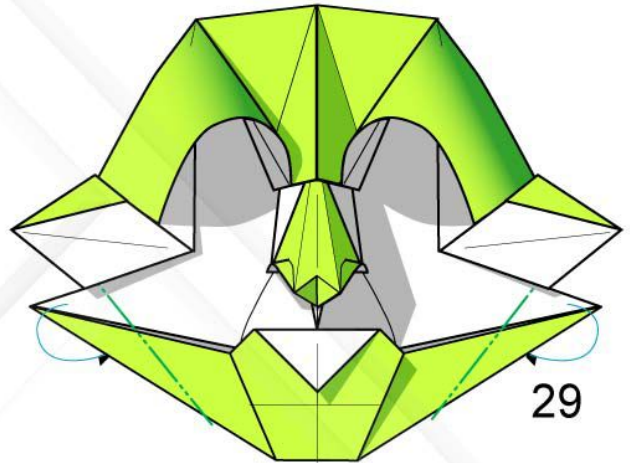

29

2 pieghe a monte e ruotate

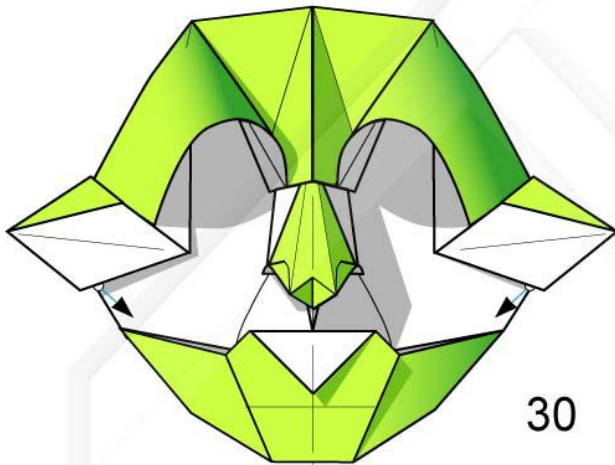

30

Estraete

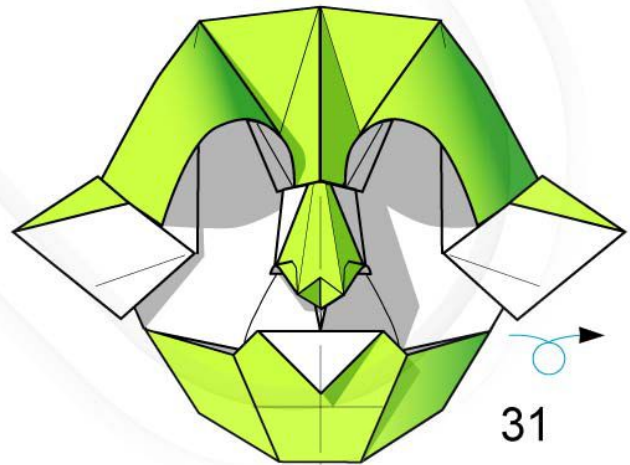

31

Ribaltate

70

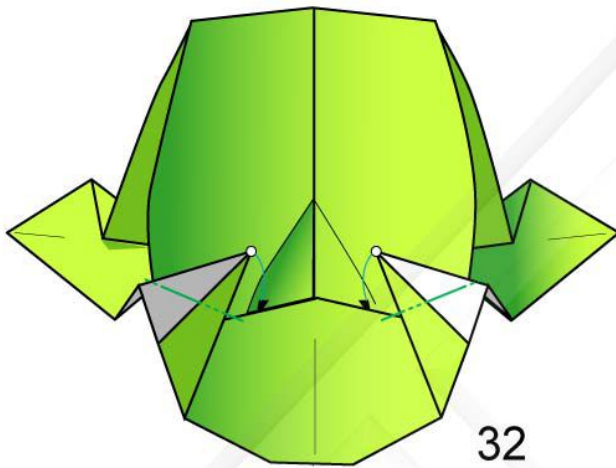

32
2 pieghe a monte ed intascate
bloccando il modello

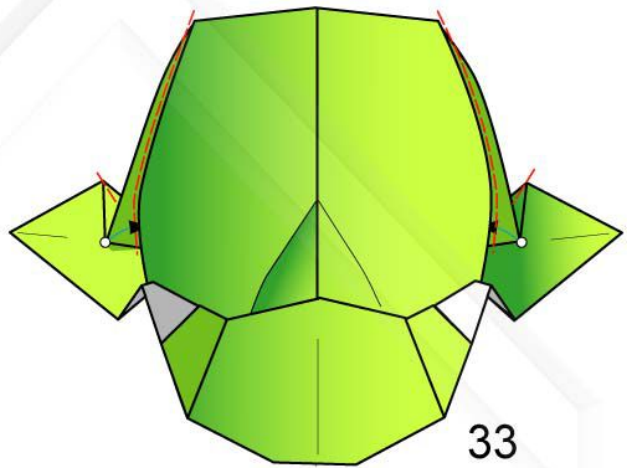

33
4 pieghe a valle e ruotate
bloccando il modello

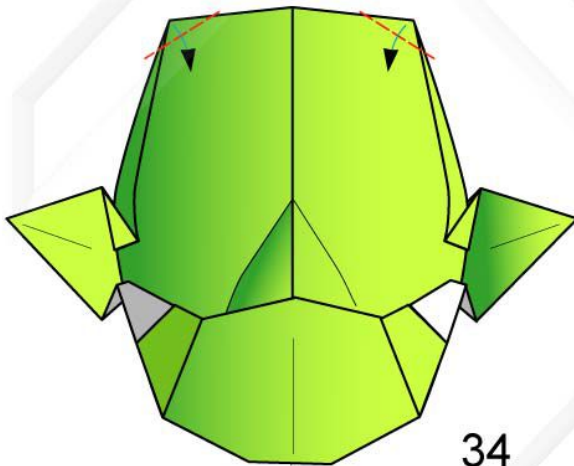

34
2 pieghe a valle e ruotate

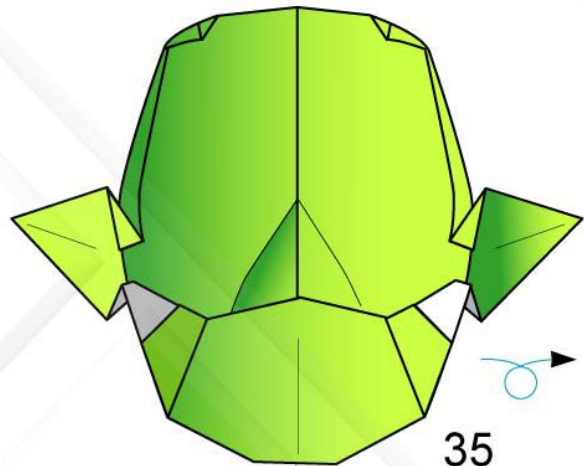

35
Ribaltate

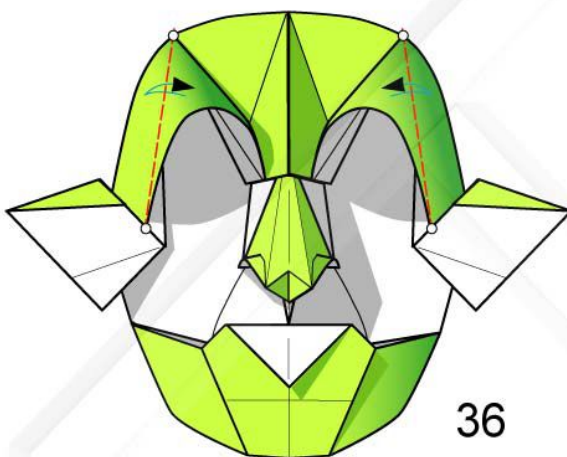

36
2 pieghe a valle e ruotate 3D

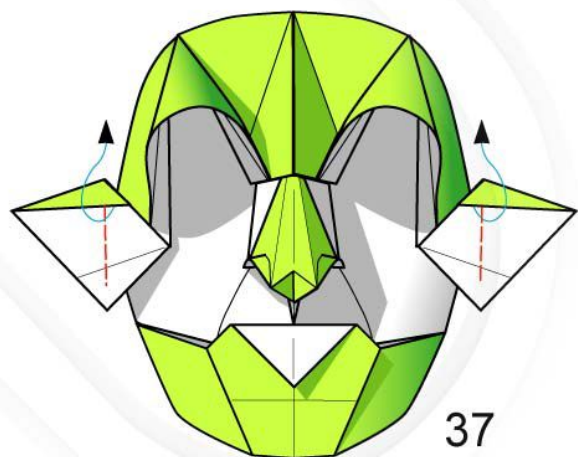

37
2 pieghe a valle ed aprite 3D

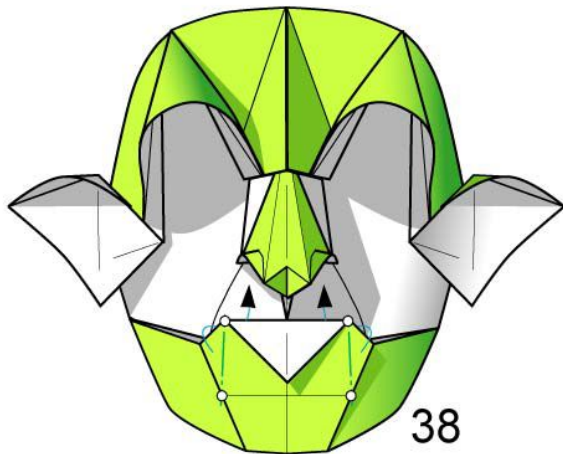

38

2 pieghe rovesce interne

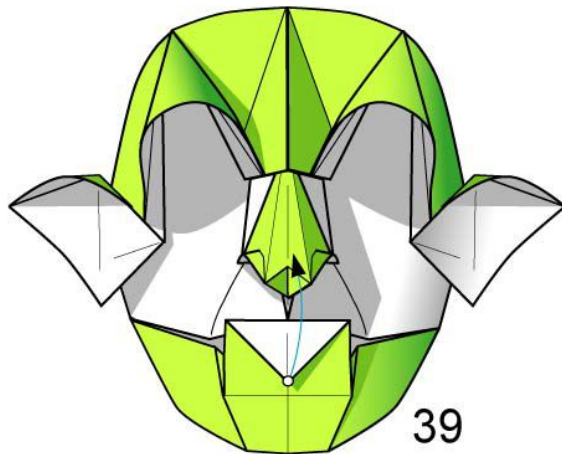

39

Ruotando sollevate

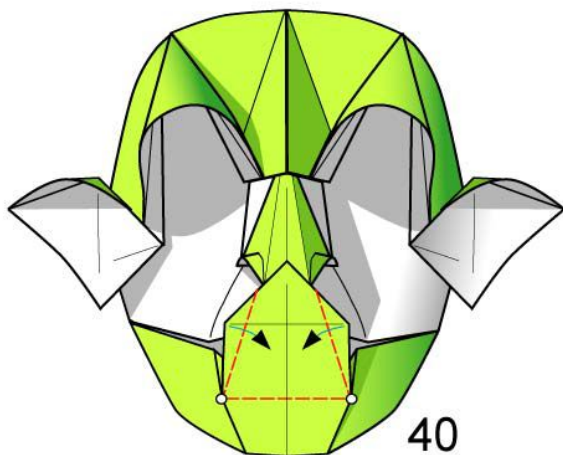

40

2 pieghe a valle e, ripiegando, ruotate 3D

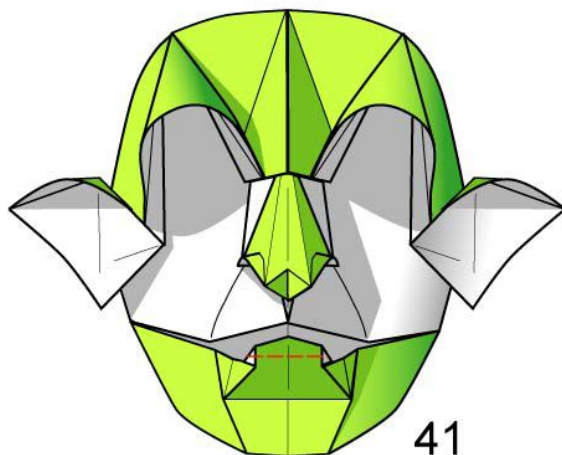

41

1 piega a valle e ruotate 3D per formare la lingua

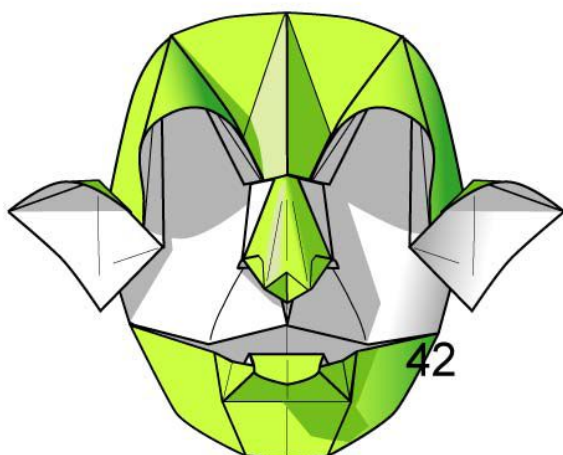

42

Maschera di Skrr ultimata

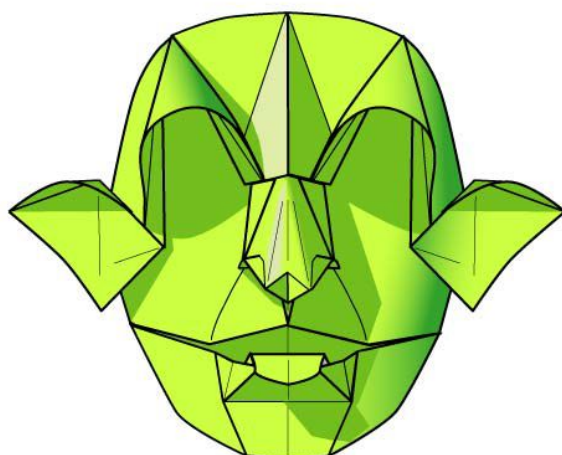

Maschera di Skrr ultimata realizzata con cartoncino monocolore



Maschera di Skrr
con occhi ritagliati



Maschera di Skrr con
occhi disegnati o incollati



VISTA DALL'ALTO



PROFILO



FRONTE



RETRO



VISTA DAL BASSO

LEONARDO



Leonardo Da Vinci è stato uno degli uomini più intelligenti di tutti i tempi, famoso per la sua versatilità: ingegnere, architetto, botanico, poeta, pittore, scultore.

Adoperate un foglio di cartoncino quadrato monocoloro di 42 cm di lato

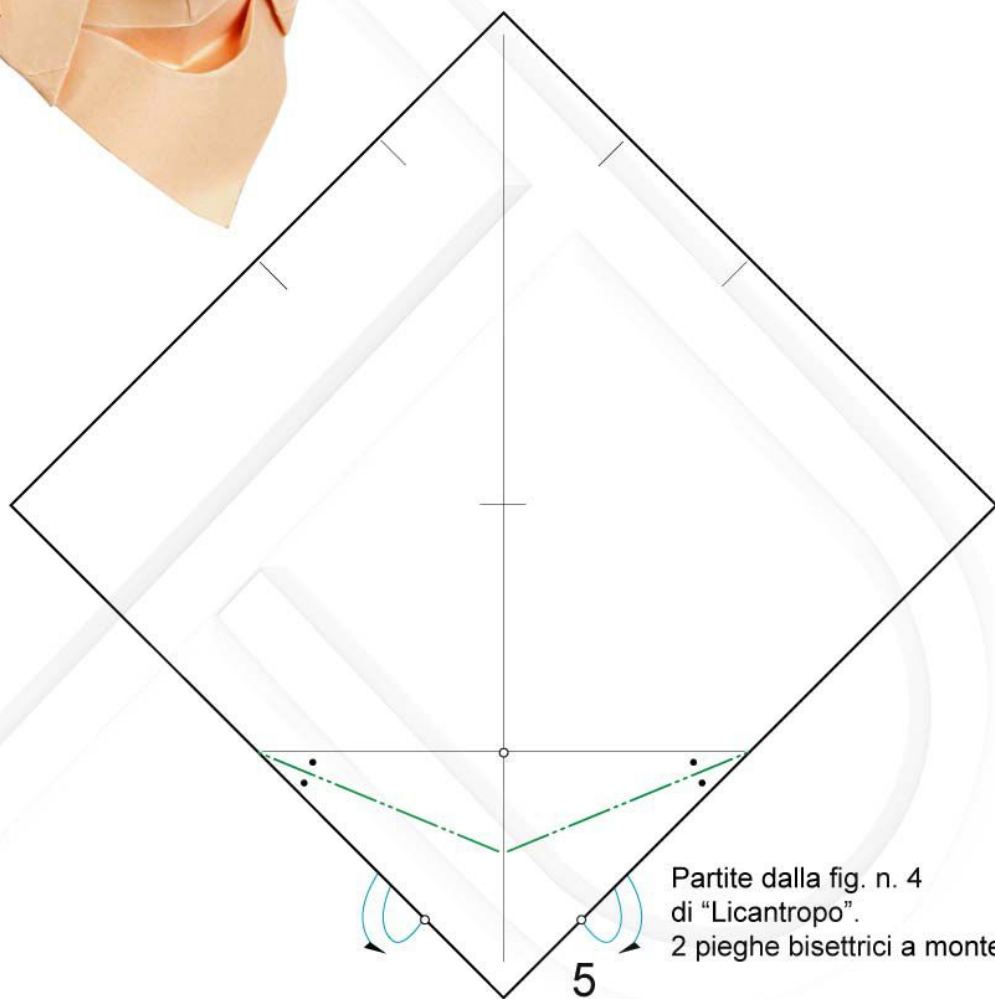

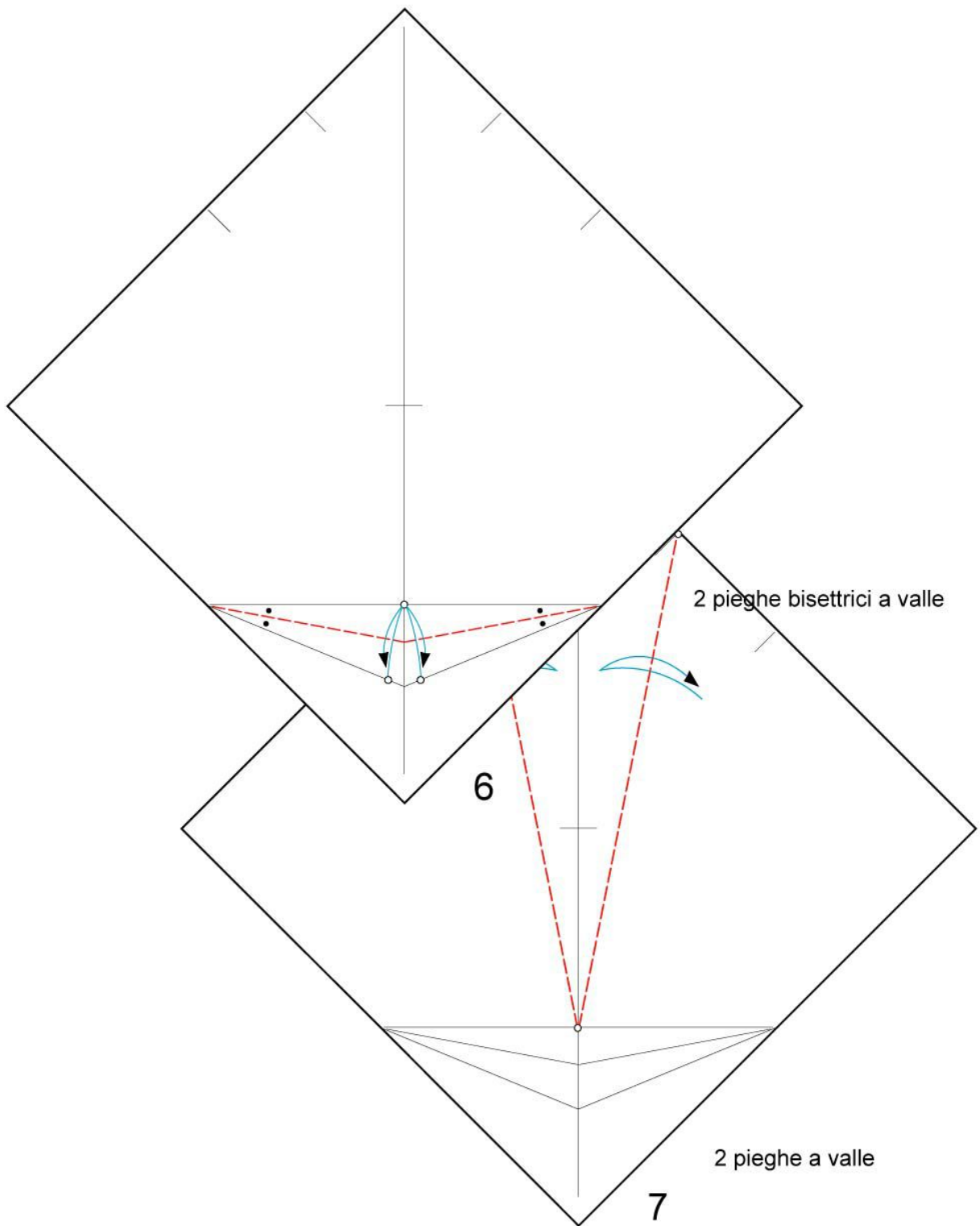

75

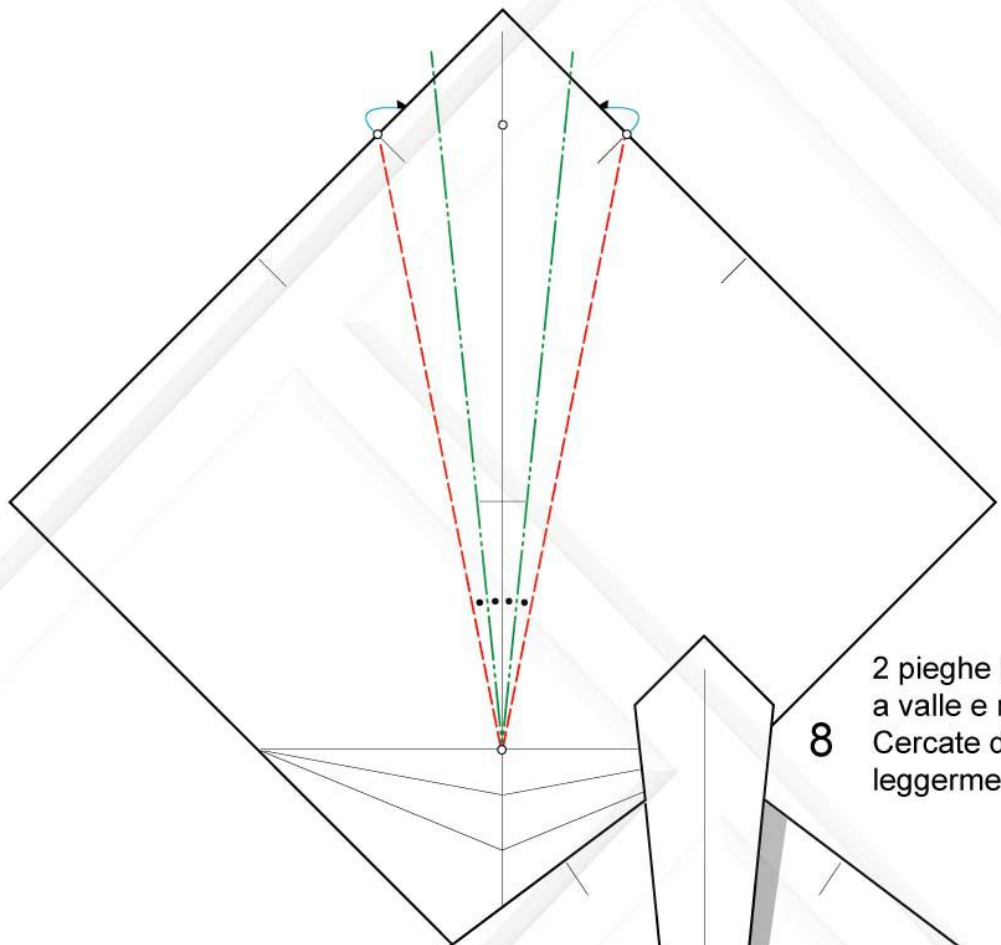

8 2 pieghe bisettrici a valle e ruotate 3D. Cercate di sovrapporre leggermente i bordi

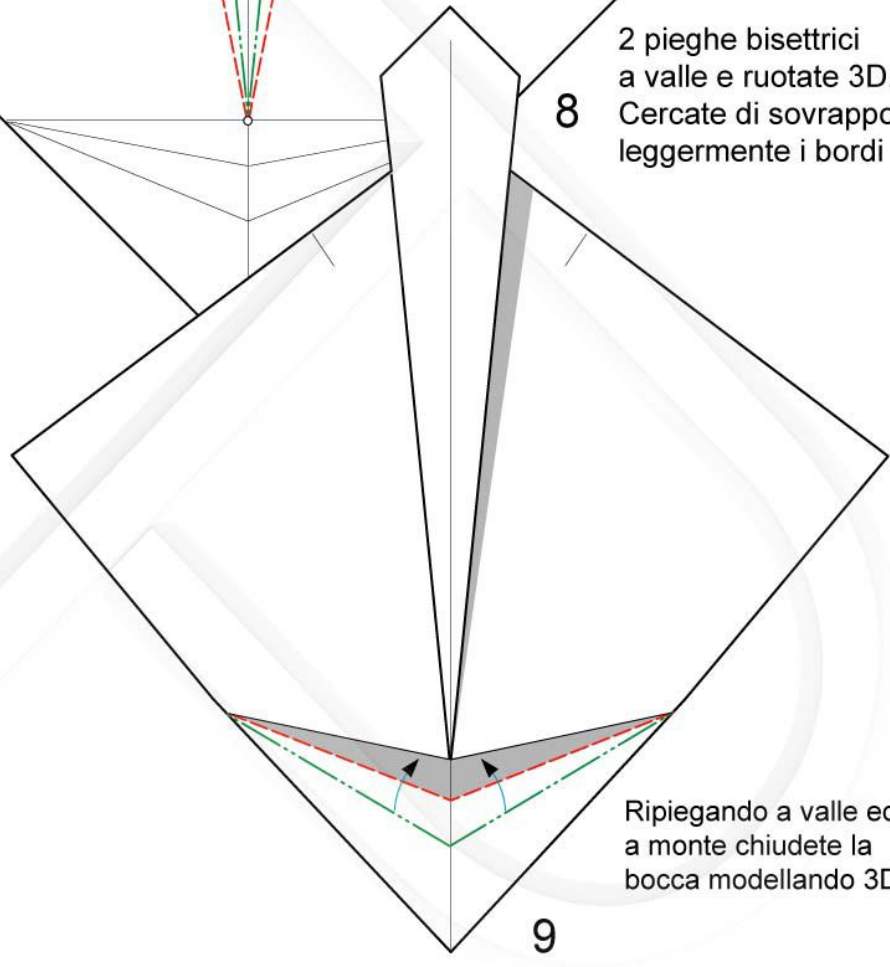

Ripiegando a valle ed a monte chiudete la bocca modellando 3D

9

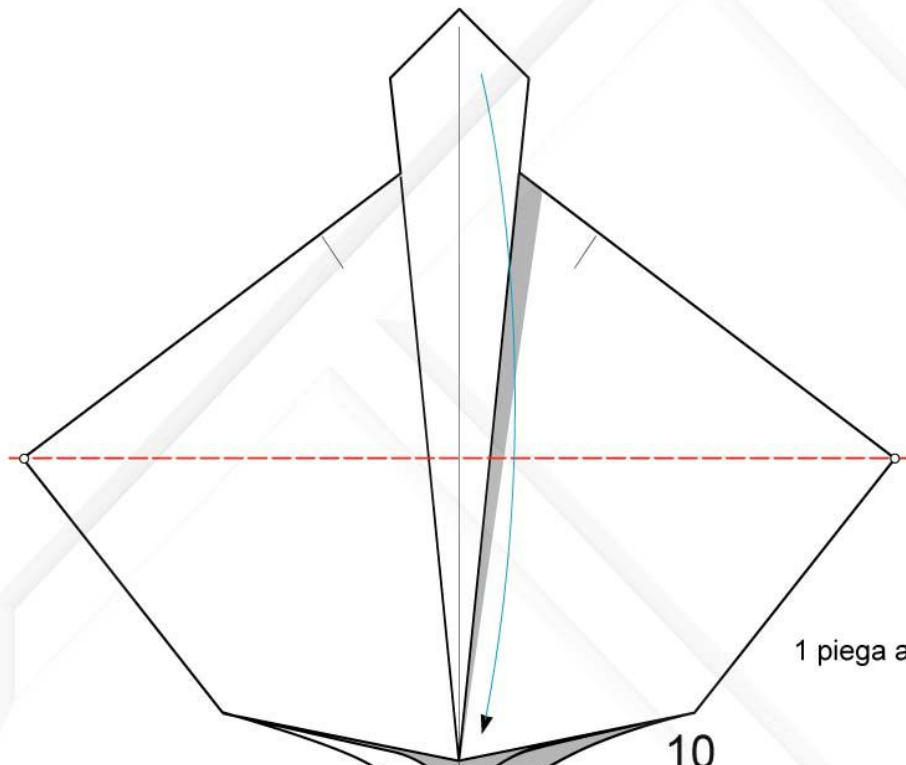

1 piega a valle e ruotate

10

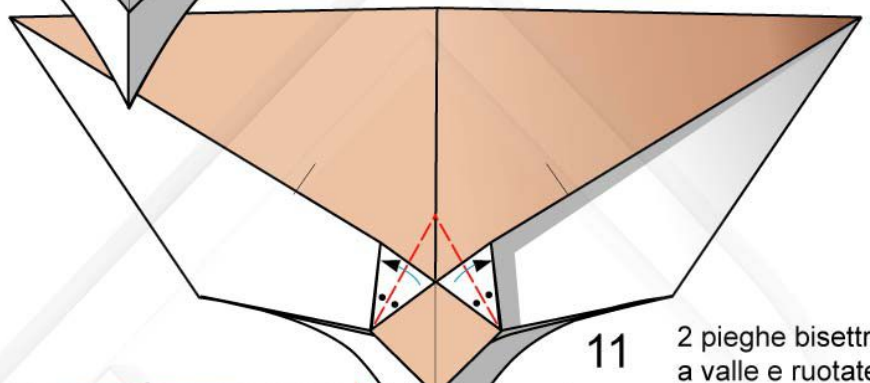

2 pieghe bisettrici a valle e ruotate

11

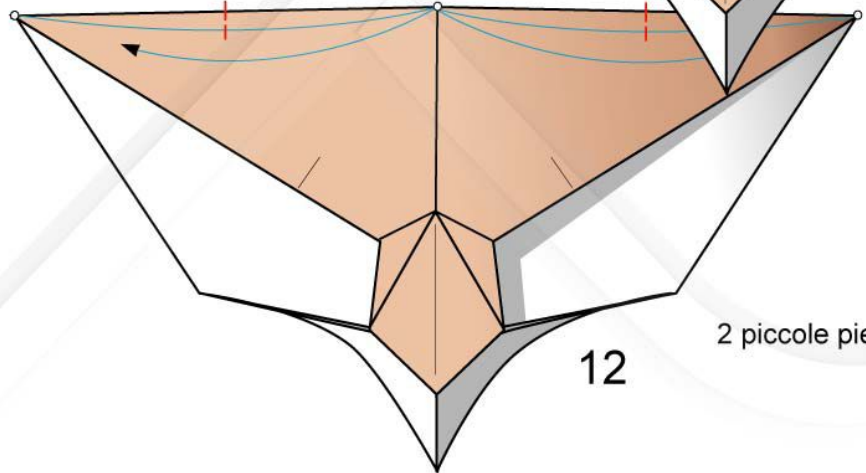

2 piccole pieghe a valle

12

77

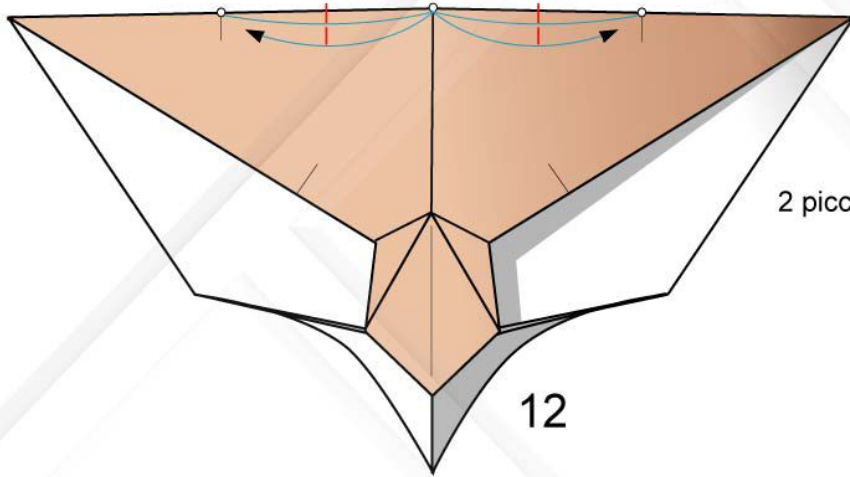

2 piccole pieghe a valle

12

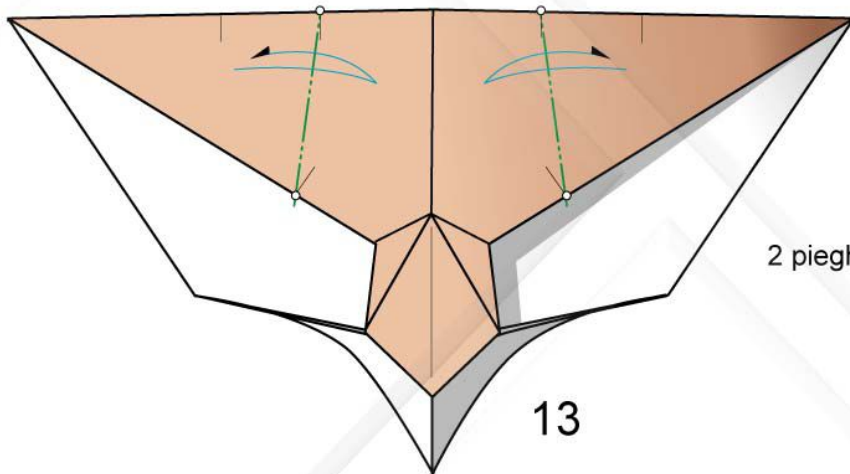

2 pieghe a monte

13

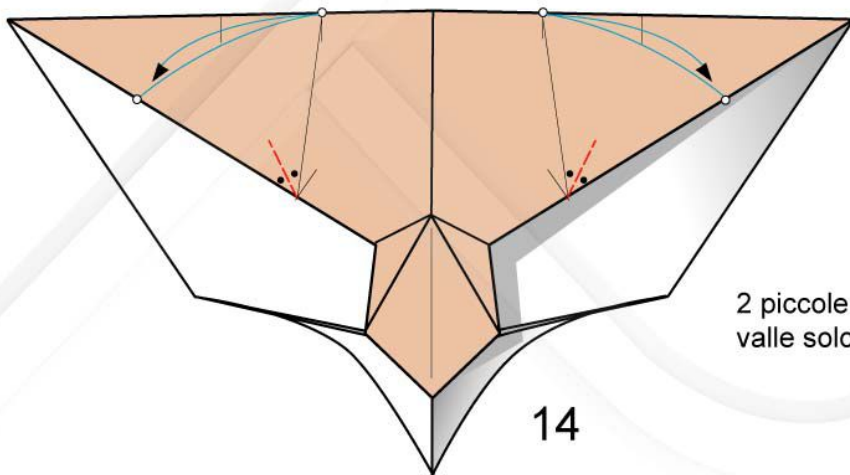

2 piccole pieghe bisettrici a valle solo sulla sup. in vista

14

78

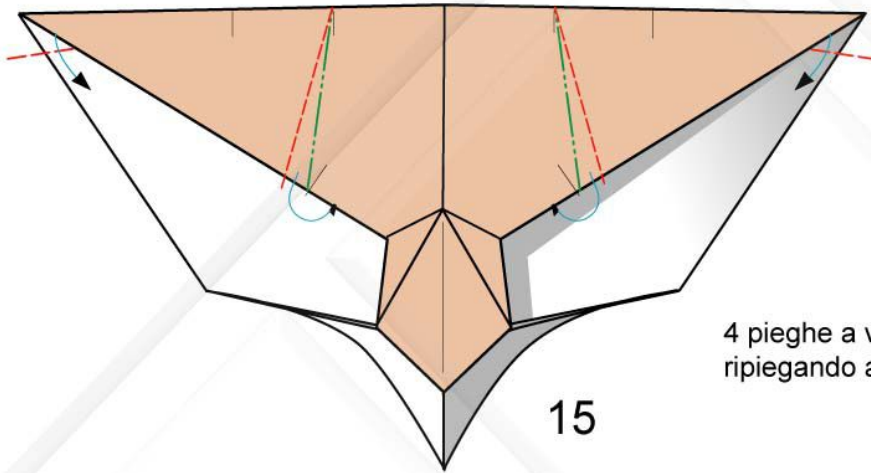

4 pieghe a valle e ruotate
ripiegando a monte

15

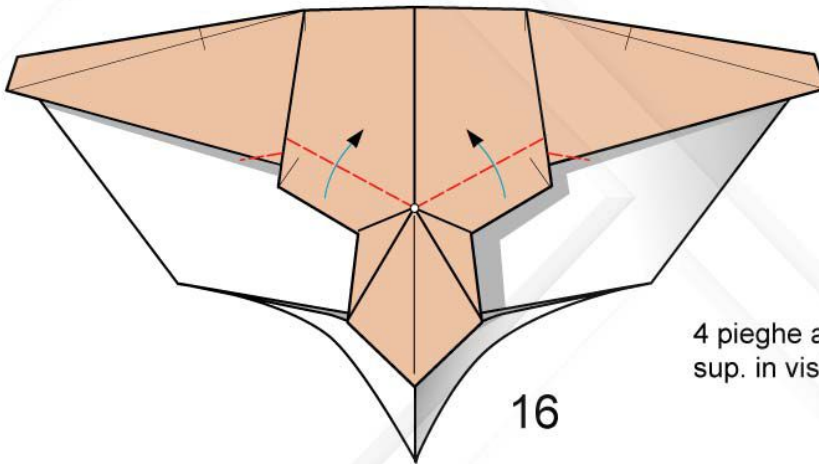

4 pieghe a valle solo sulla
sup. in vista e ruotate

16

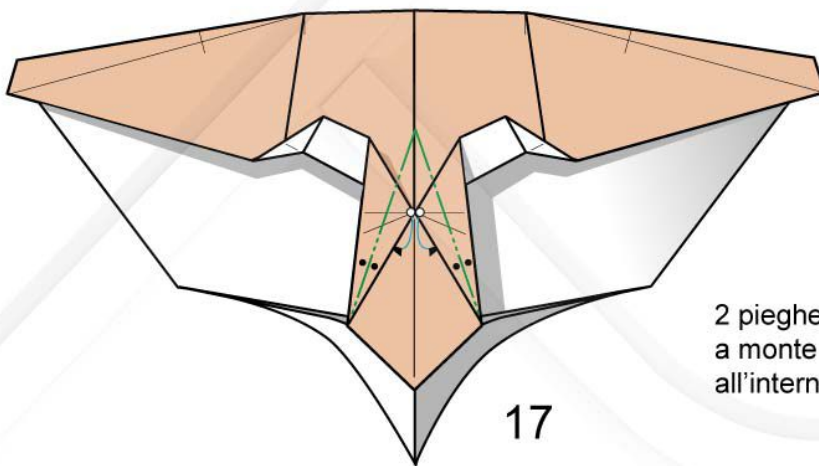

2 pieghe bisettrici
a monte e ruotate
all'interno

17

79

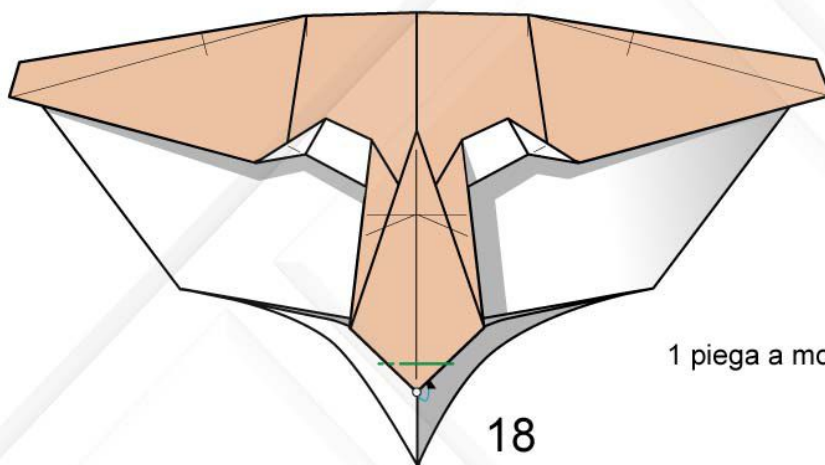

1 piega a monte e ruotate

18

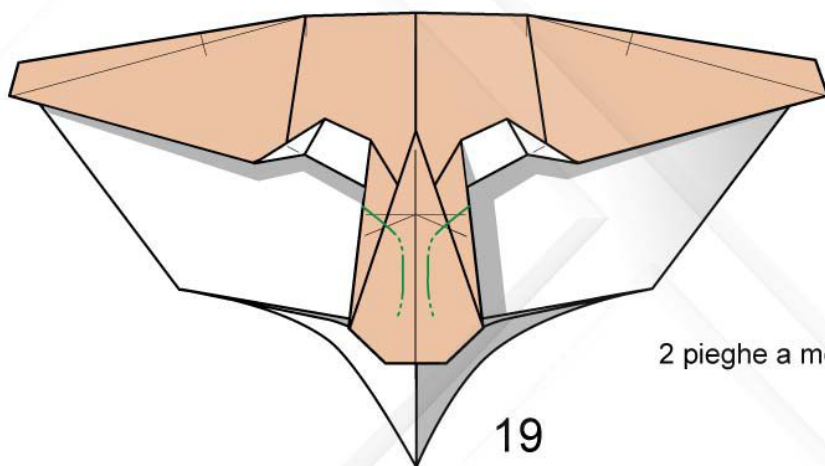

2 pieghe a monte morbide

19

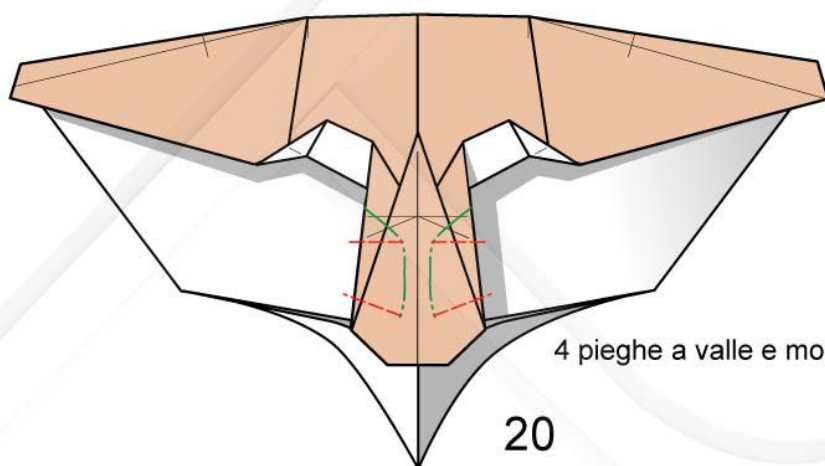

4 pieghe a valle e modellate il naso 3D

20

80

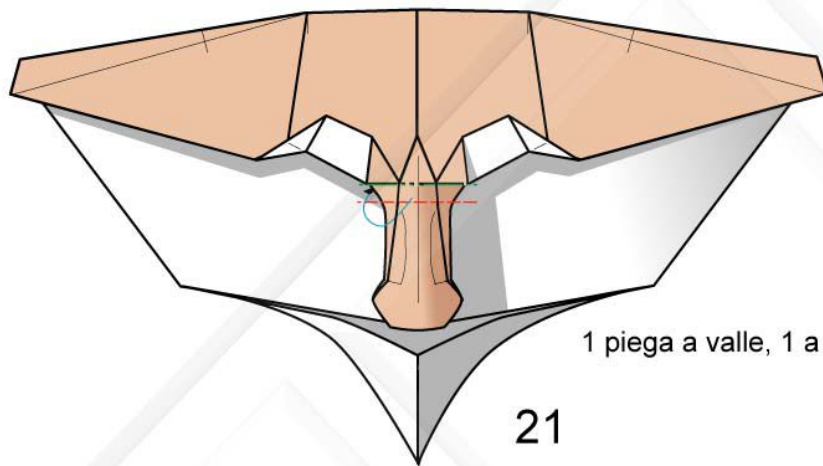

1 piega a valle, 1 a monte e piegate a "z"

21

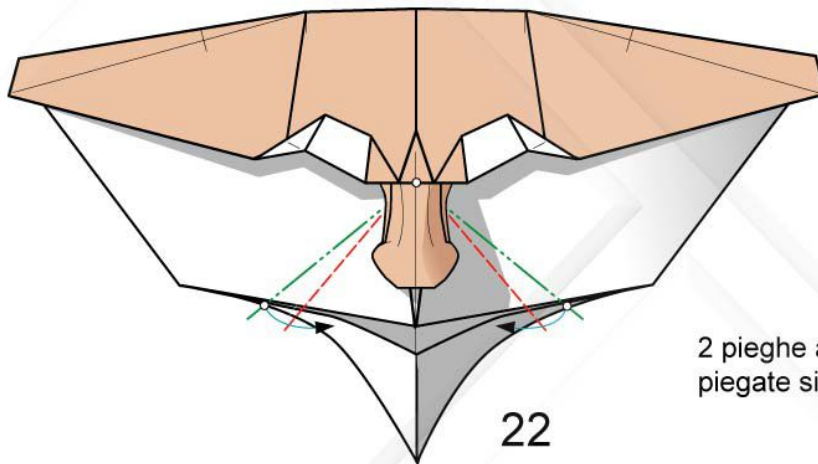

2 pieghe a valle, 2 a monte e
piegate simmetricamente a "z"

22

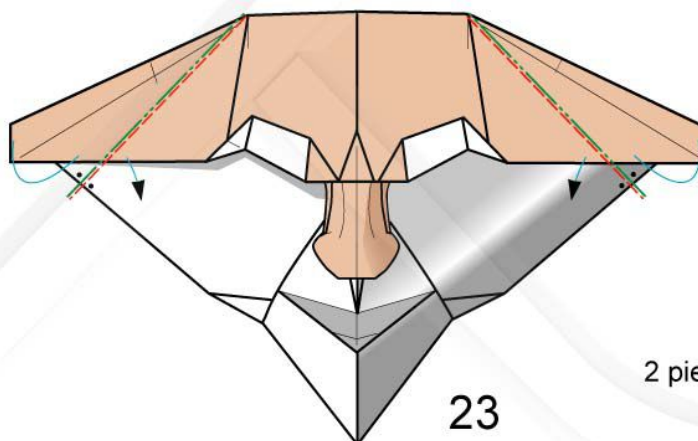

2 pieghe rovesce interne

23

81

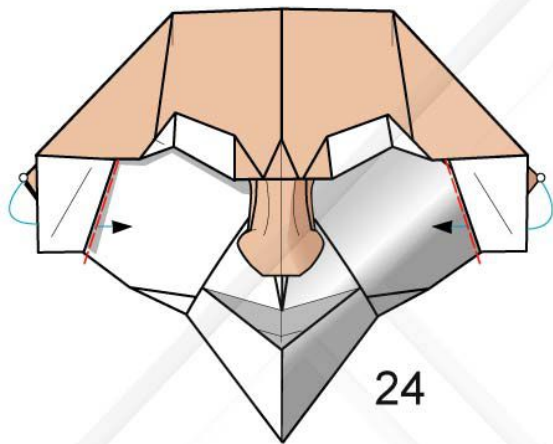

24

2 pieghe a monte e ruotate all'indietro

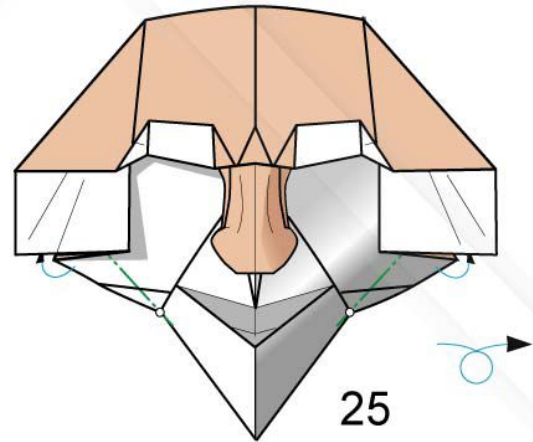

25

2 pieghe a monte, ruotate all'indietro e ribaltate

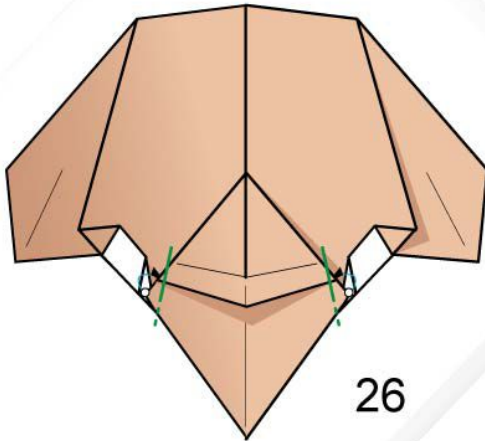

26

2 pieghe a monte e ruotate all'indietro bloccando

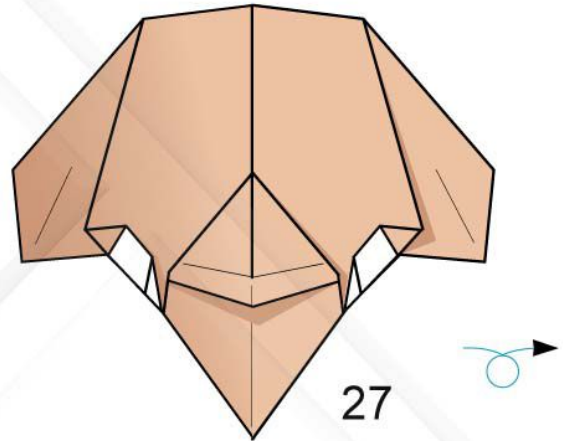

27

Ribaltate

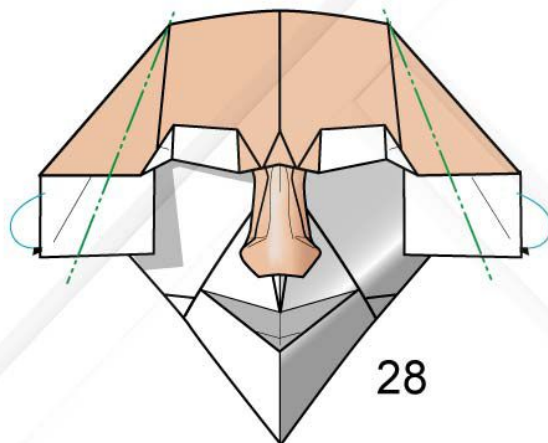

28

2 pieghe a monte e ruotate all'indietro

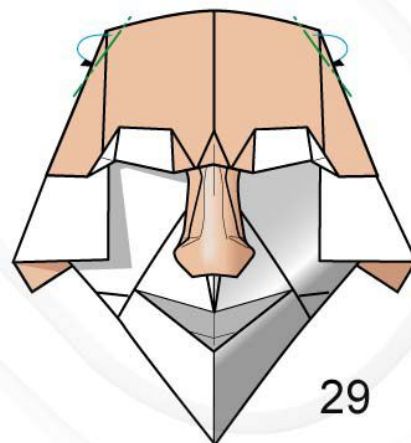

29

2 pieghe a monte e ruotate all'indietro

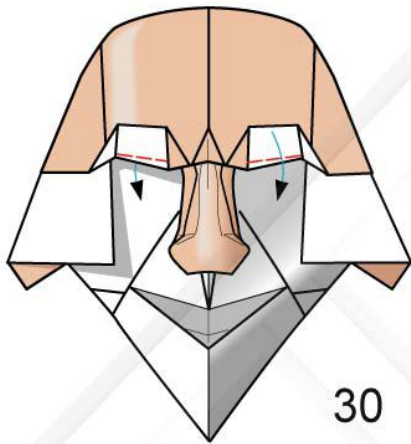

30

2 pieghe a monte e ruotate 3D in avanti per formare le sopracciglia

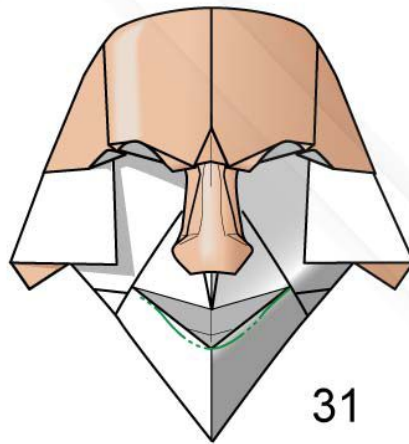

31

Mediante una piega a monte curva arrotondate 3D la bocca

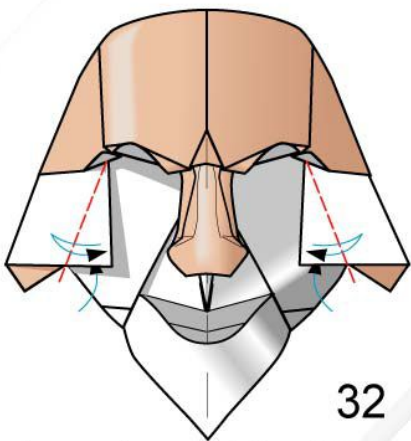

32

2 pieghe a valle e modellate 3D a cono solo sulla sup. in vista per formare i capelli

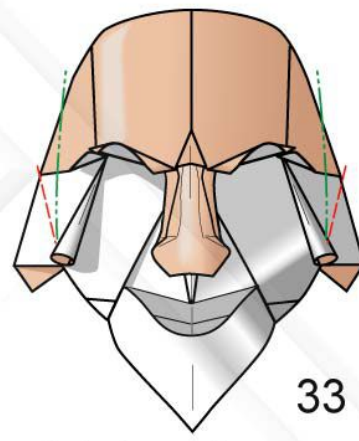

33

2 pieghe a valle e 2 a monte per formare i capelli

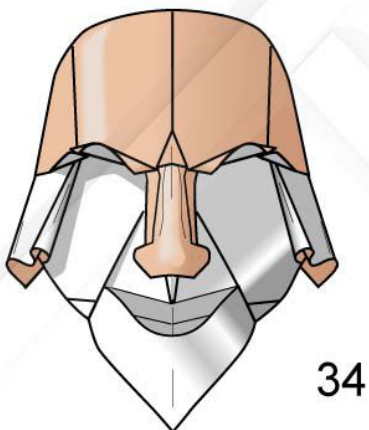

34

Maschera di Leonardo ultimata

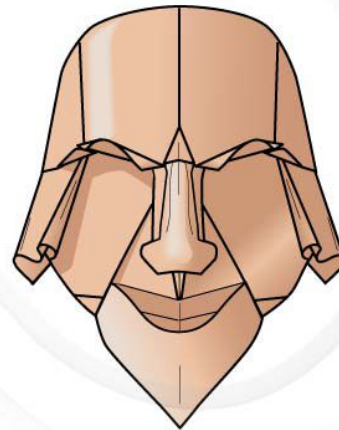

Maschera di Leonardo ultimata realizzata con cartoncino monocoloro

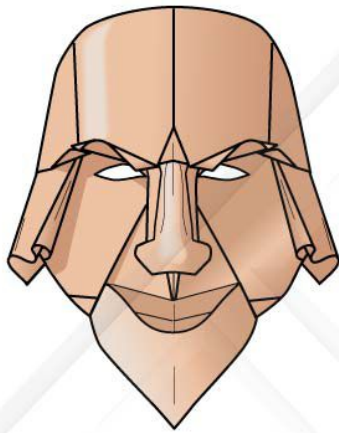

Maschera di Leonardo
con occhi ritagliati

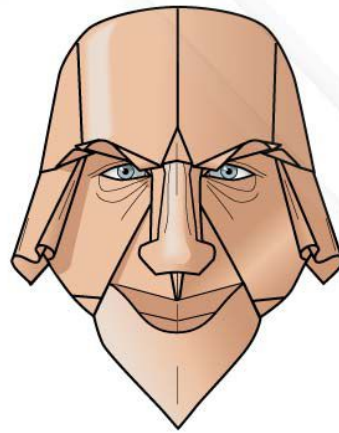

Maschera di Leonardo
con occhi disegnati o incollati



VISTA DALL'ALTO



PROFILO



FRONTE



RETRO



VISTA DAL BASSO

MERLINO



La maschera raffigura il celebre mago amico di Re Artù ed è basata costruttivamente sul modello precedente.

Partite da un foglio di cartoncino quadrato monocolore di 45 cm di lato.

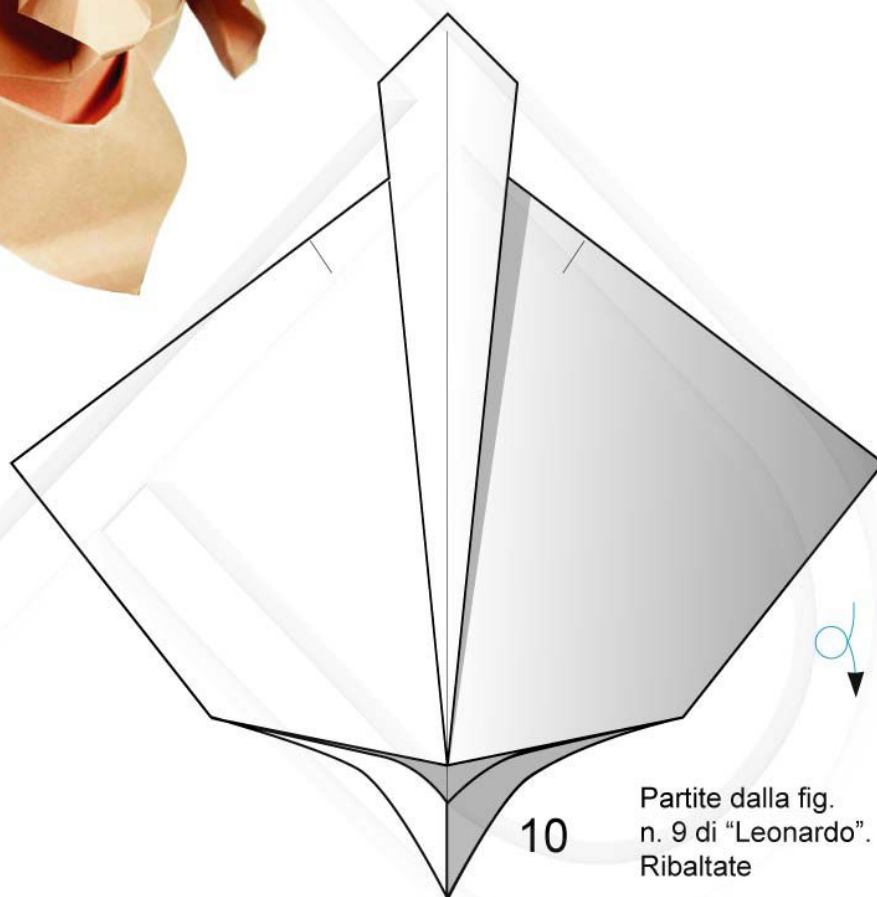

Partite dalla fig.
n. 9 di "Leonardo".
Ribaltate

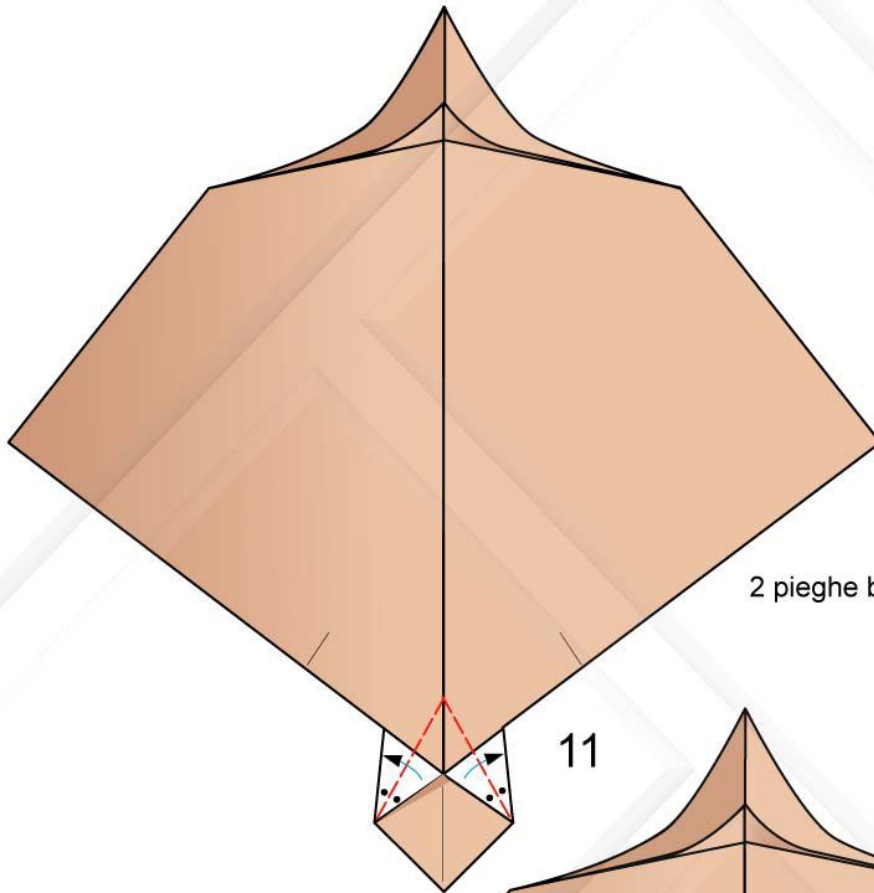

2 pieghe bisettrici a valle e ruotate

11

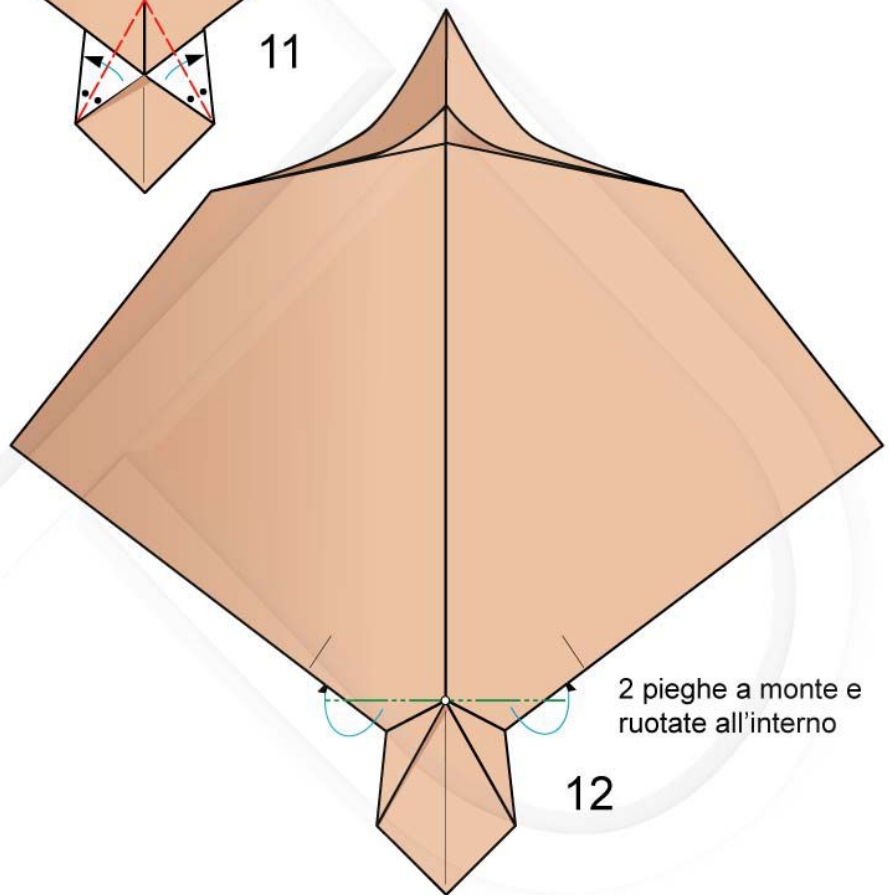

2 pieghe a monte e ruotate all'interno

12

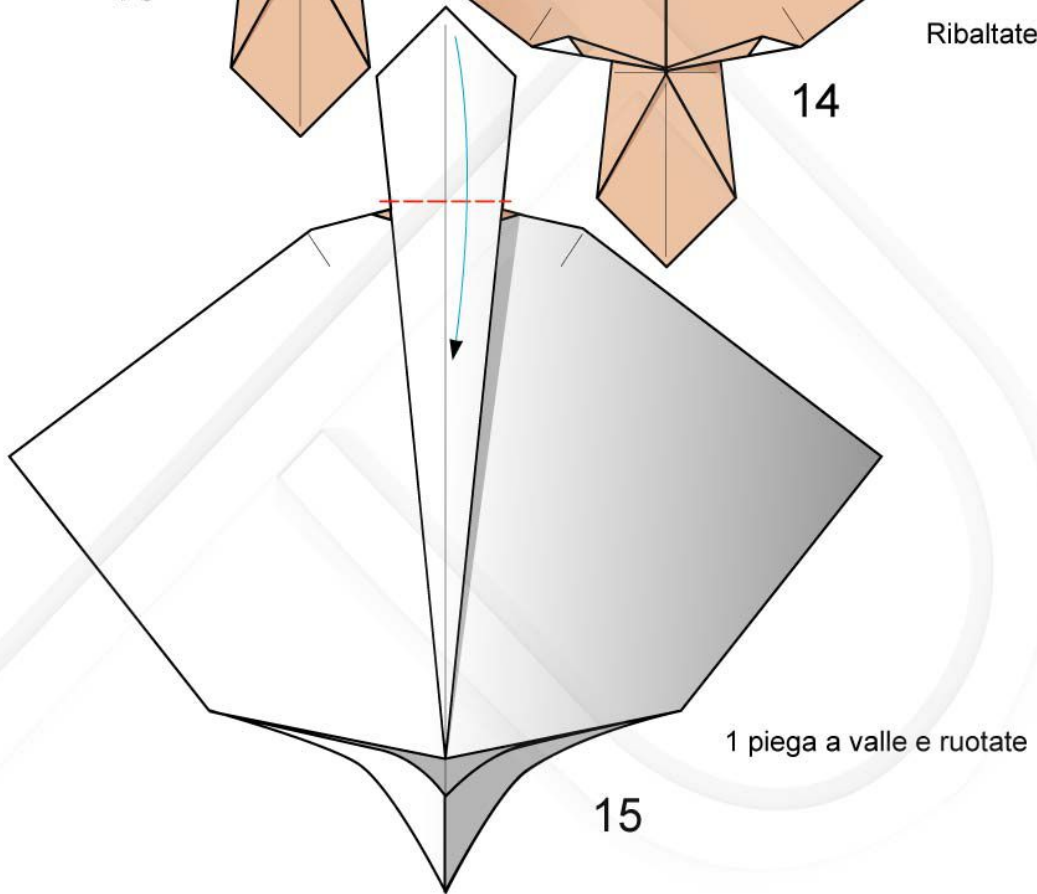
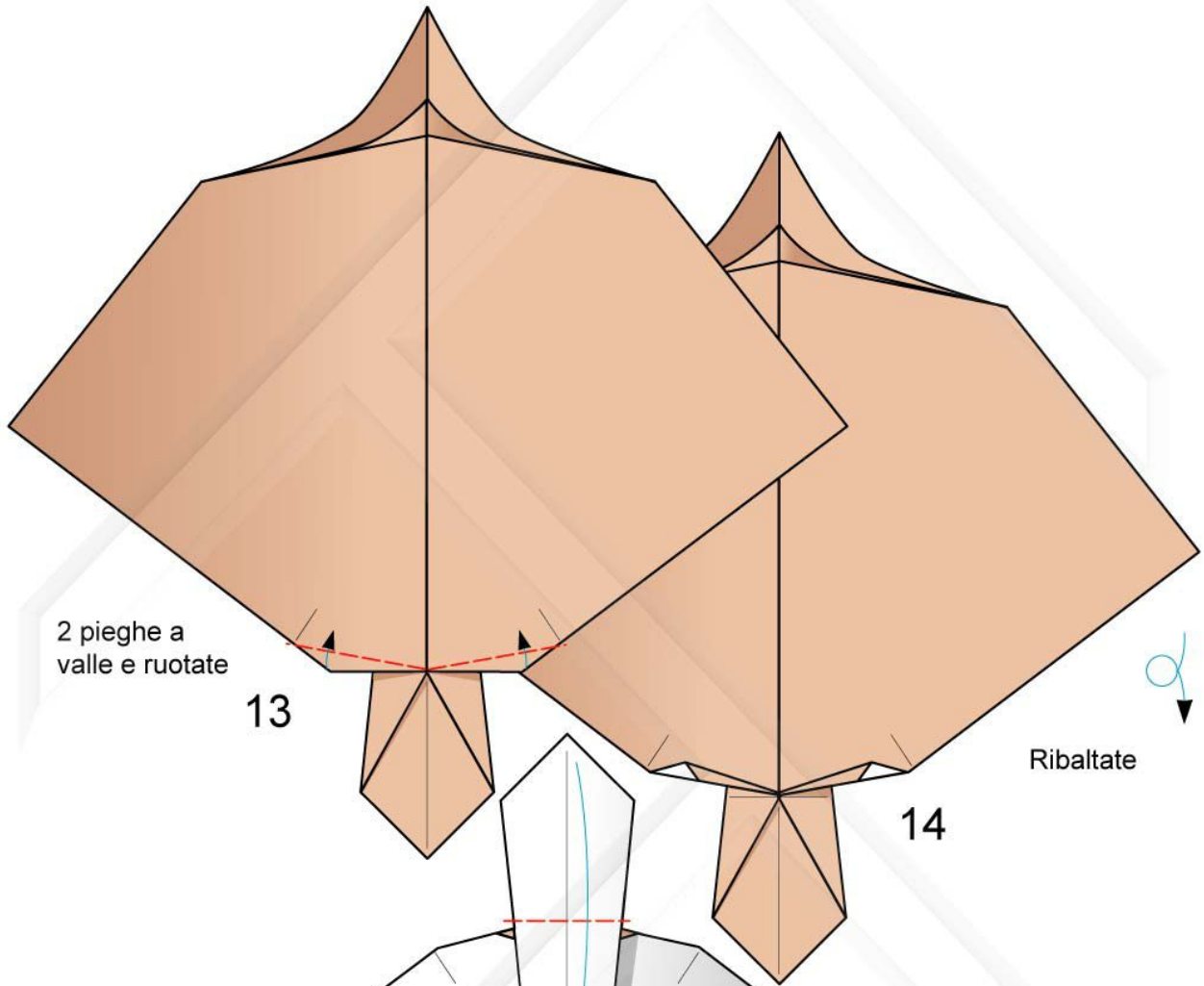

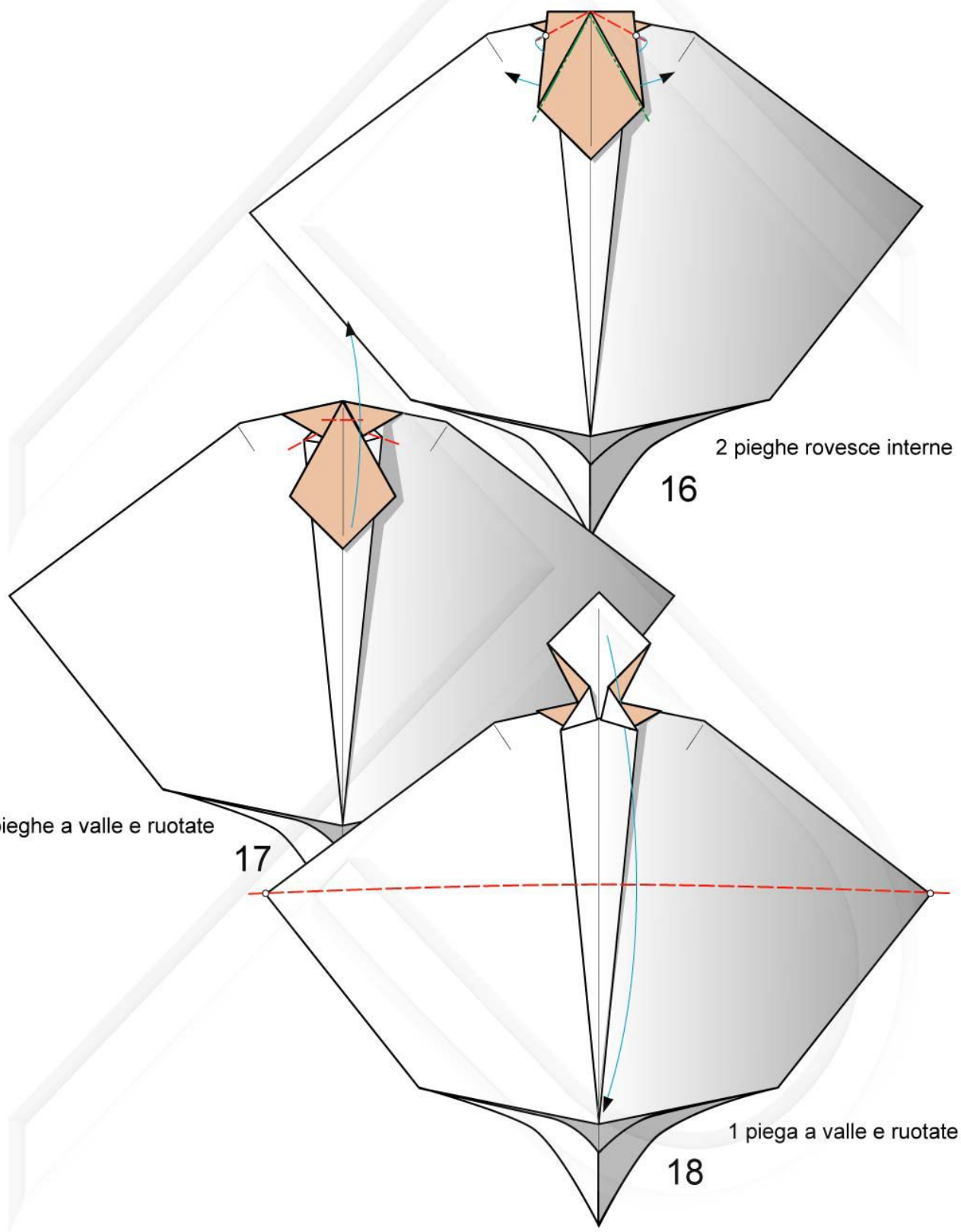

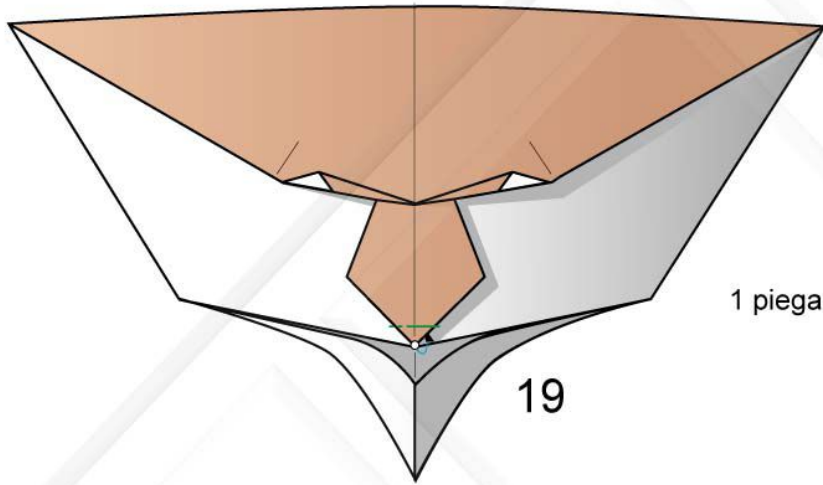

1 piega a valle e ruotate

19

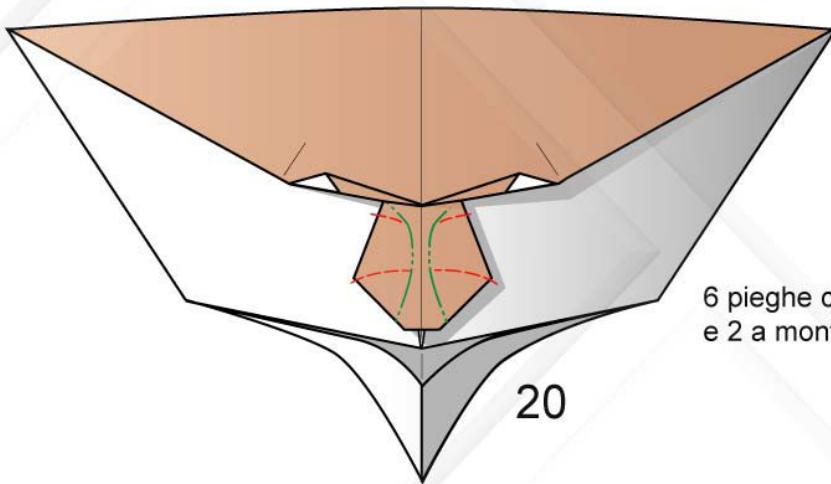

6 pieghe curve, 4 a valle
e 2 a monte morbide e ruotate

20

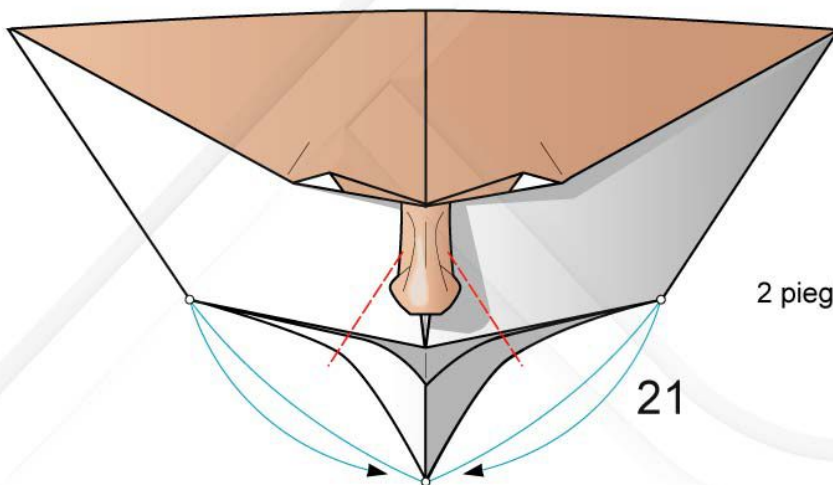

2 pieghe a valle

21

89

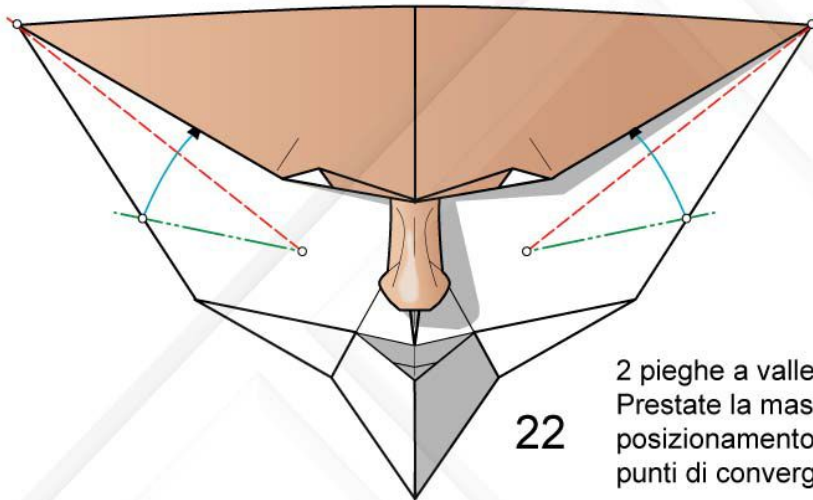

22

2 pieghe a valle, 2 a monte e ruotate 3D.
Prestate la massima attenzione nel
posizionamento e nella simmetria dei
punti di convergenza nelle guance

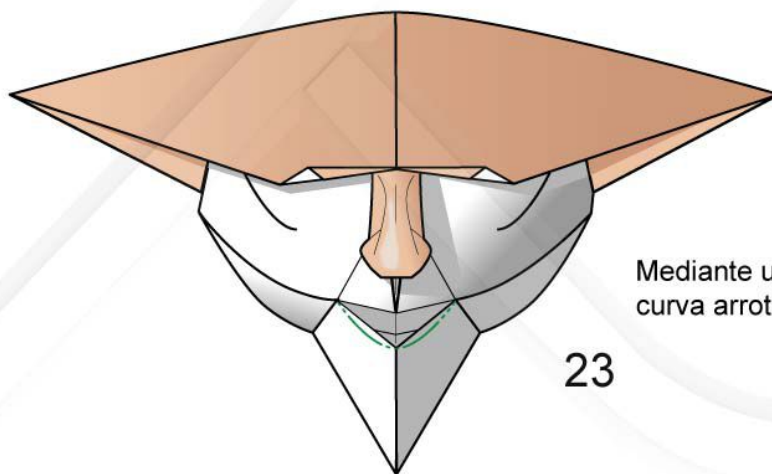
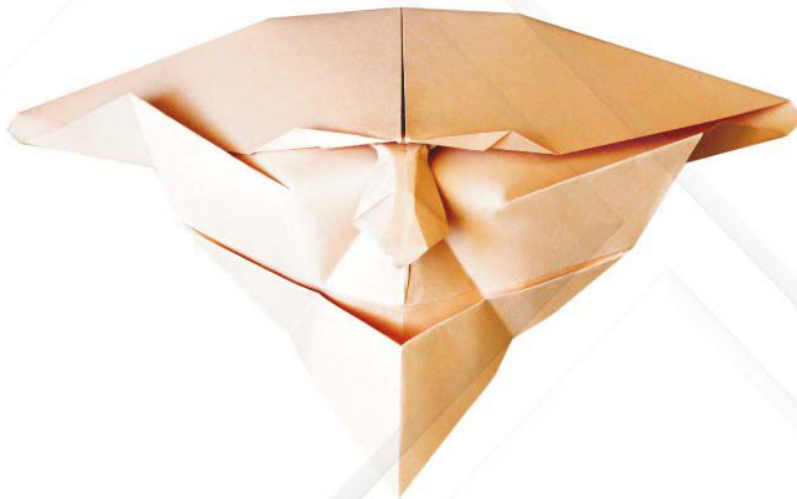

23

Mediante una piega a monte
curva arrotondate 3D la bocca

90

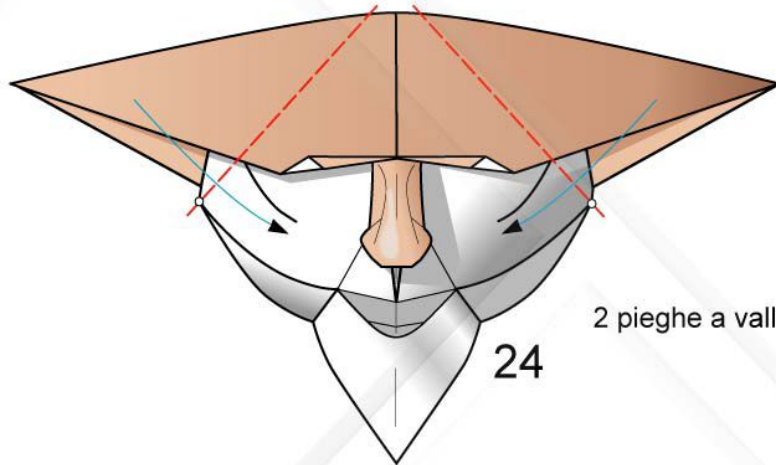

2 pieghe a valle e ruotate

24

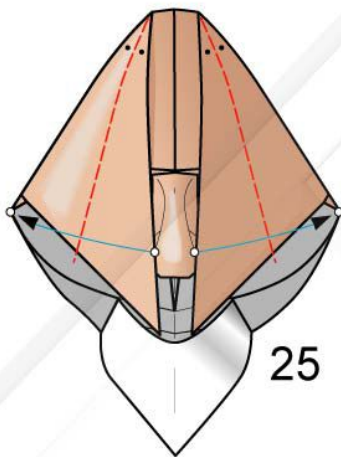

25

2 pieghe a valle e ruotate

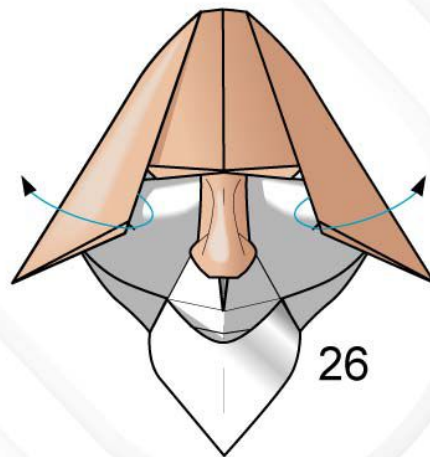

26

Estraete le superfici interne

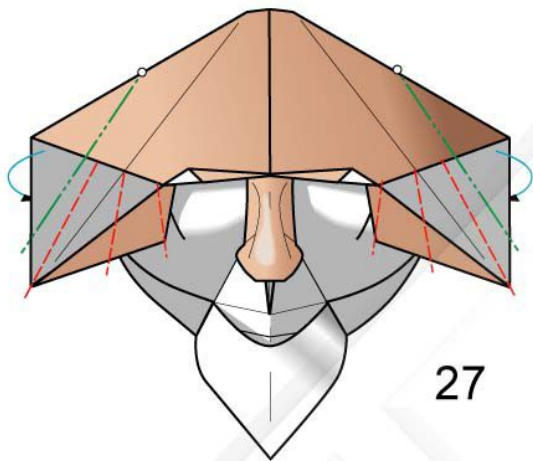

27

6 pieghe a valle e 2 a monte e ruotate 3D

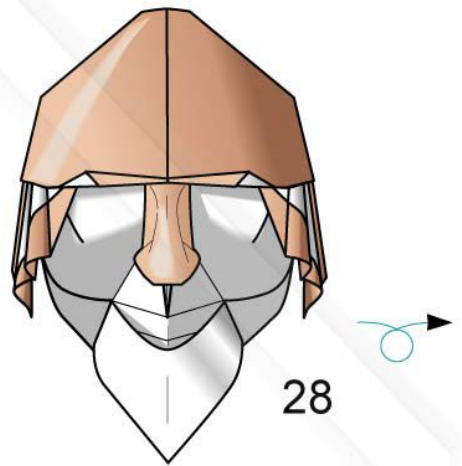

28

Ribaltate

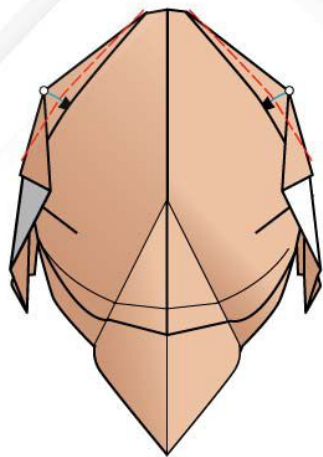

29

2 pieghe a valle e ruotate

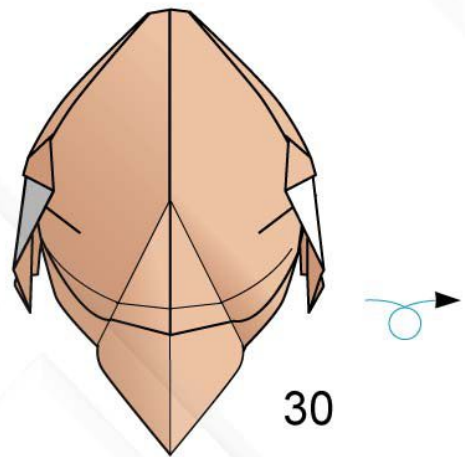

30

Ribaltate

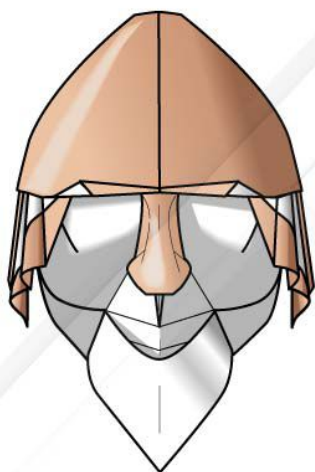

31

Maschera di Merlino ultimata

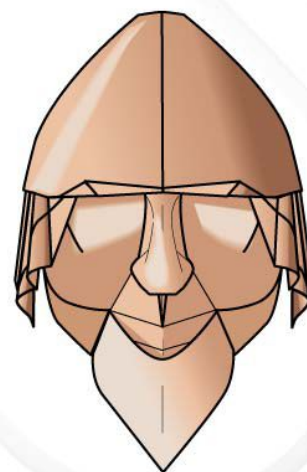

Maschera di Merlino ultimata realizzata con cartoncino monocoloro

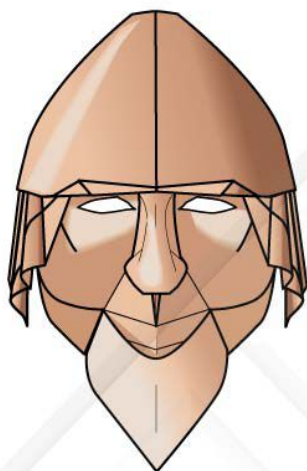

Maschera di Merlino
con occhi ritagliati

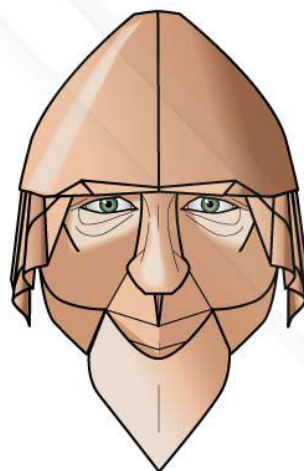

Maschera di Merlino con
occhi disegnati o incollati



VISTA DALL'ALTO



PROFILO



FRONTE



RETRO



VISTA DAL BASSO

MEO LIN



Sconosciuto coltivatore di riso della Cina meridionale.

Partite da un foglio di cartoncino quadrato monocolore di 45 cm di lato.

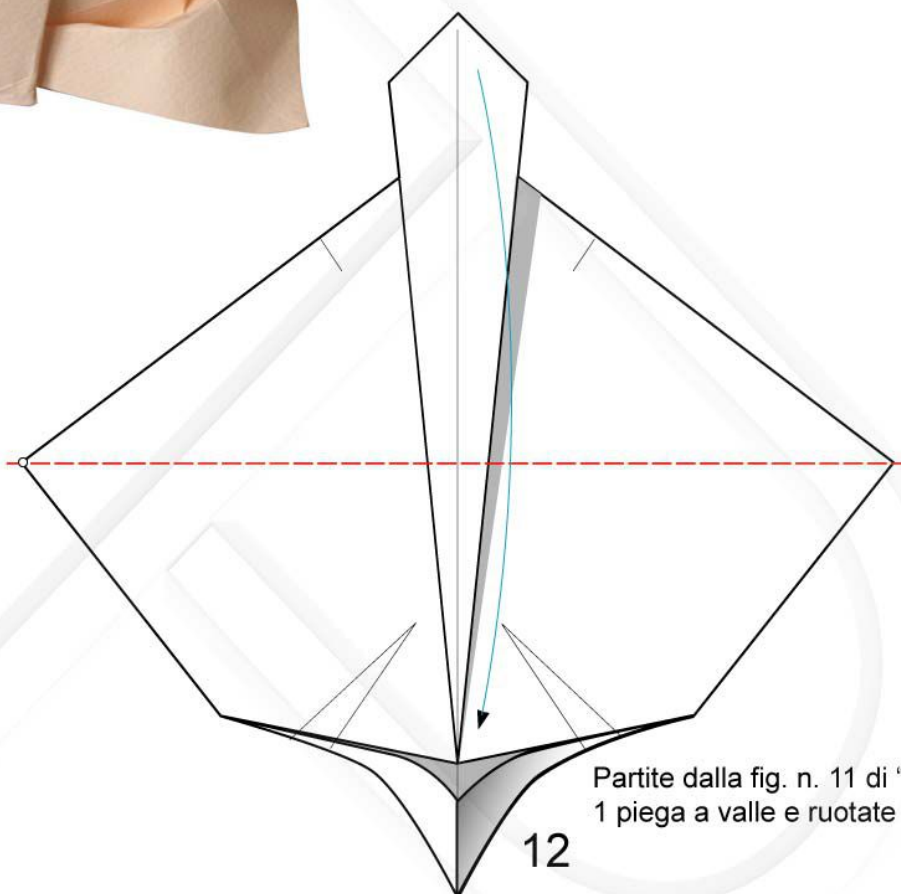

Partite dalla fig. n. 11 di "Merlino".
1 piega a valle e ruotate

12

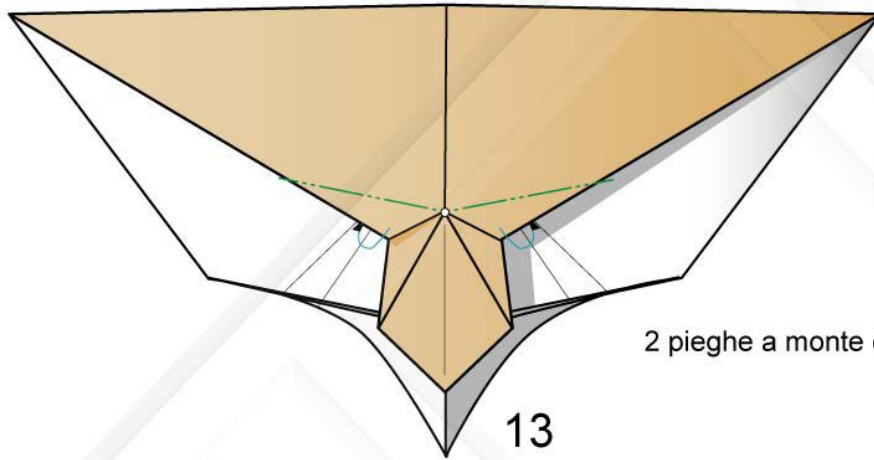

2 pieghe a monte e ruotate

13

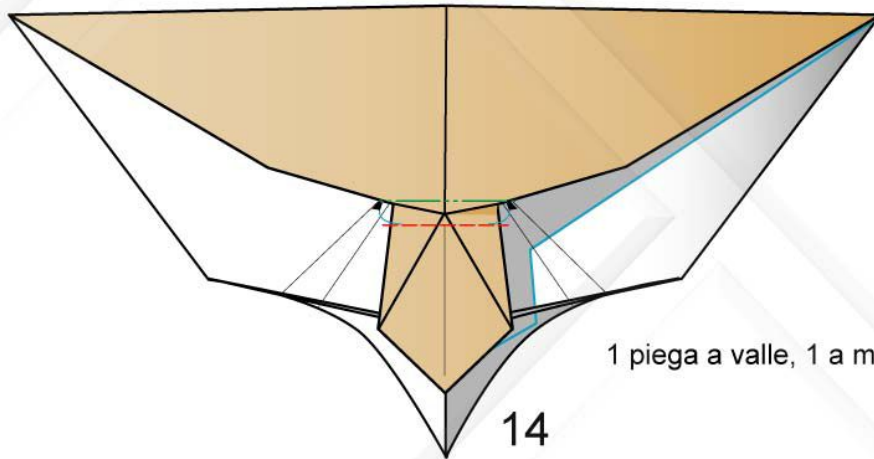

1 piega a valle, 1 a monte e ruotate a "z"

14

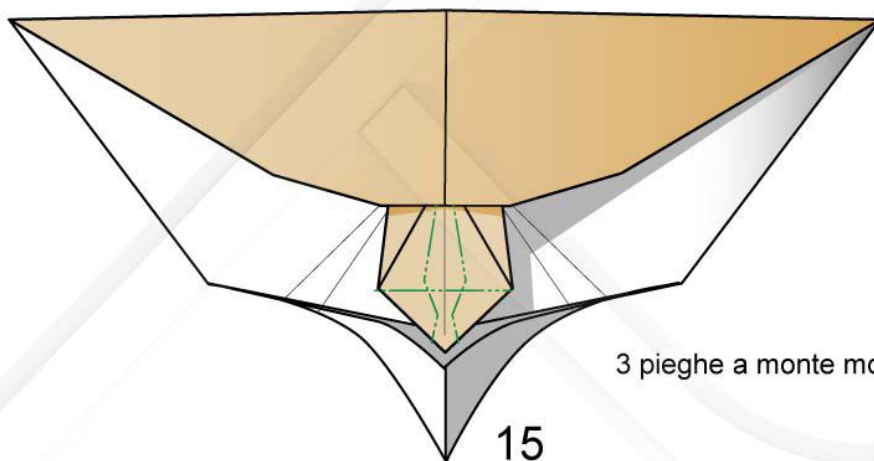

3 pieghe a monte morbide e ruotate 3D

15

95

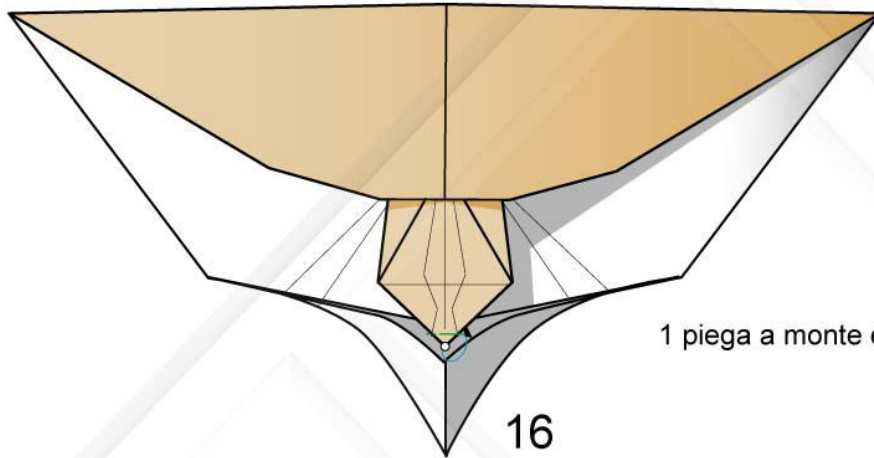

1 piega a monte e ruotate

16

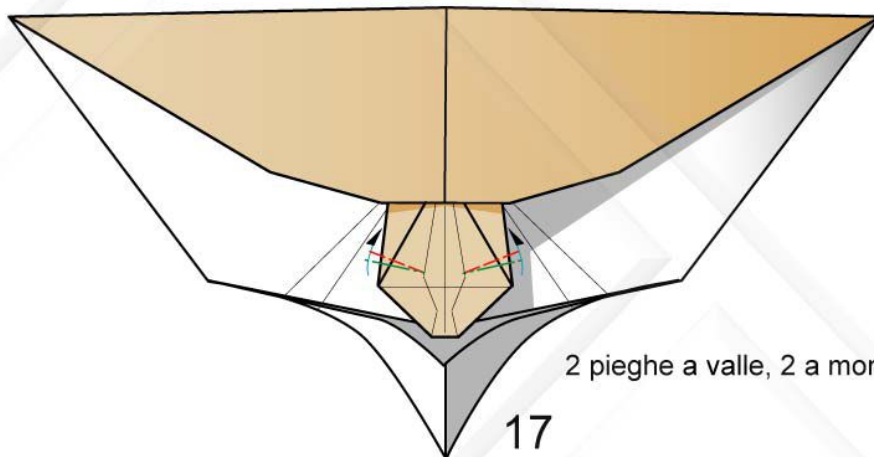

2 pieghe a valle, 2 a monte e ruotate 3D a "z"

17

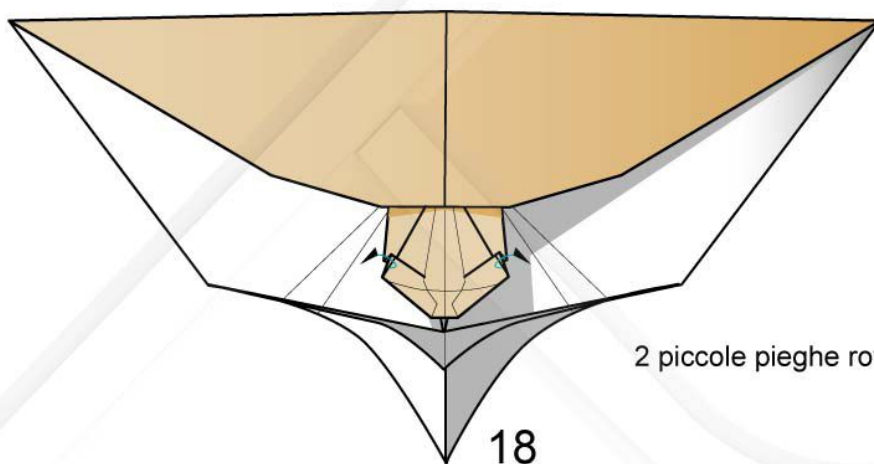

2 piccole pieghe rovesce esterne

18

96

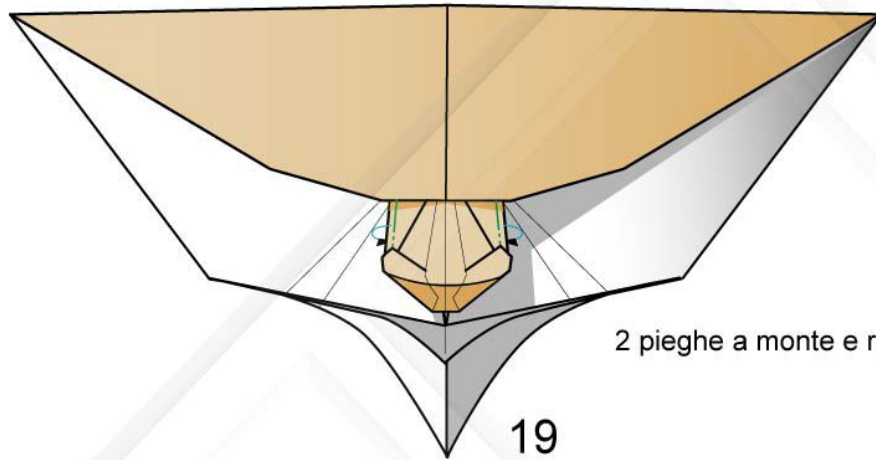

2 pieghe a monte e ruotate all'interno

19

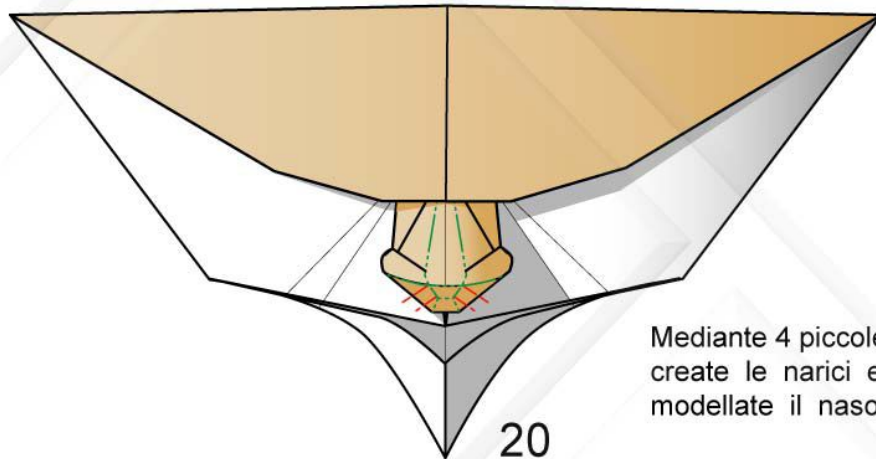

Mediante 4 piccole pieghe a valle create le narici e, ripiegando, modellate il naso 3D

20

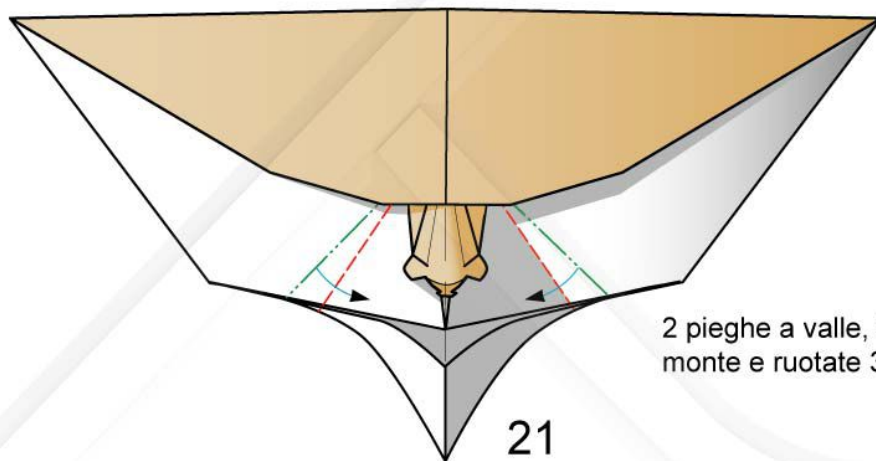

2 pieghe a valle, 2 a monte e ruotate 3D a "z"

21

97

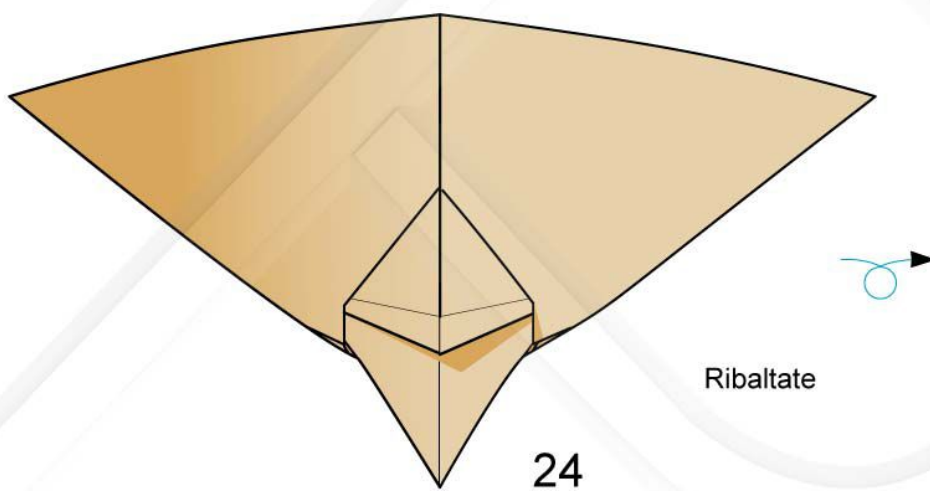
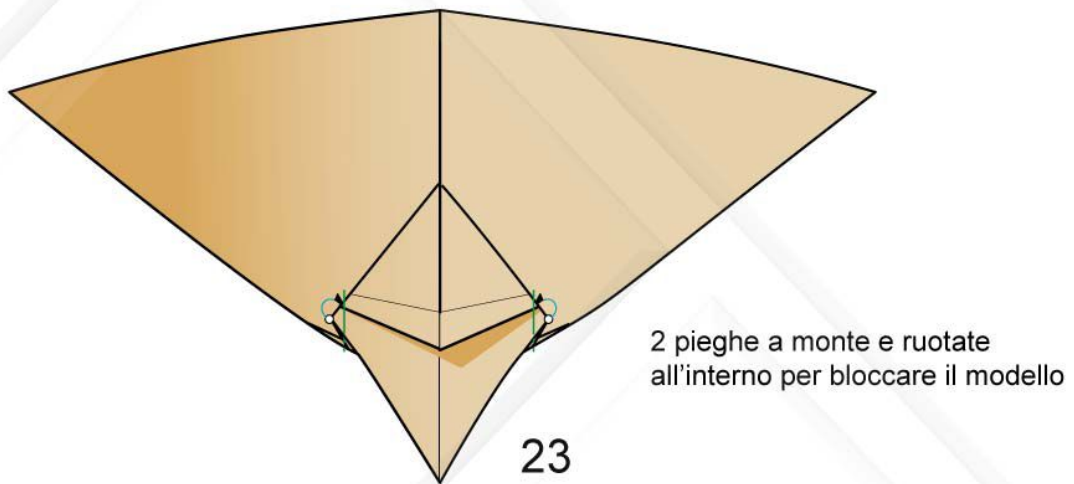
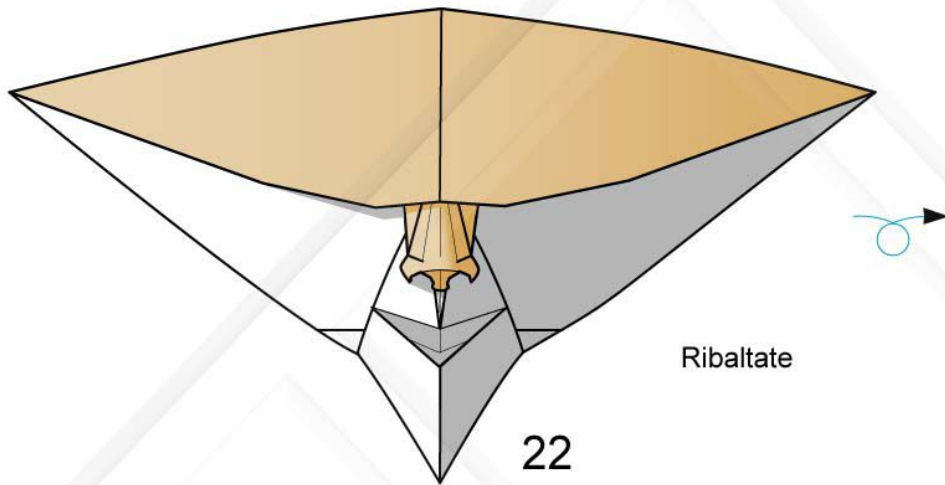

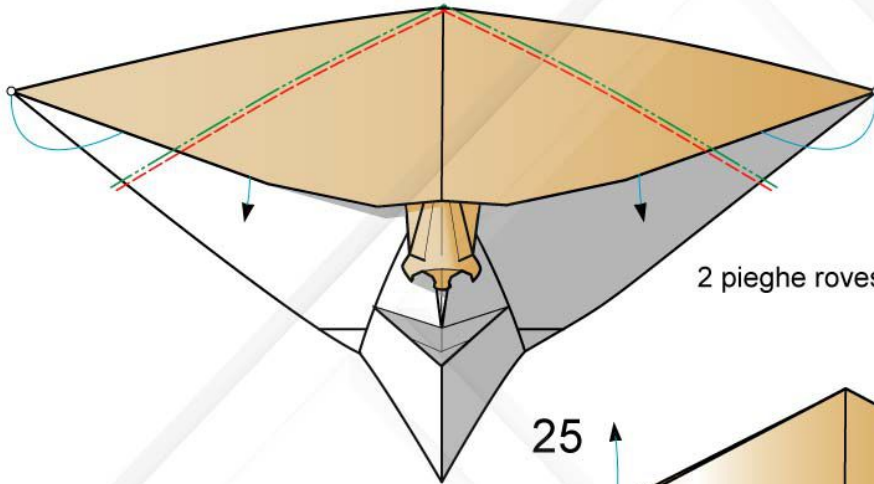

2 pieghe rovesce interne

25

2 pieghe a valle e ruotate 3D

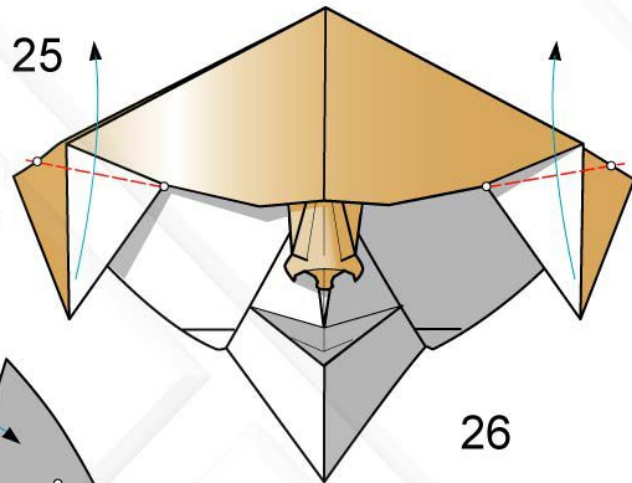

26

Estraete i vertici sottostanti rovesciando le superfici in vista

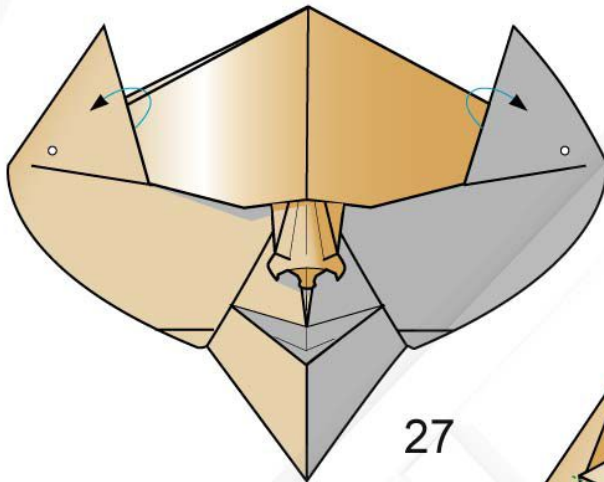

27

4 pieghe a valle e ruotate

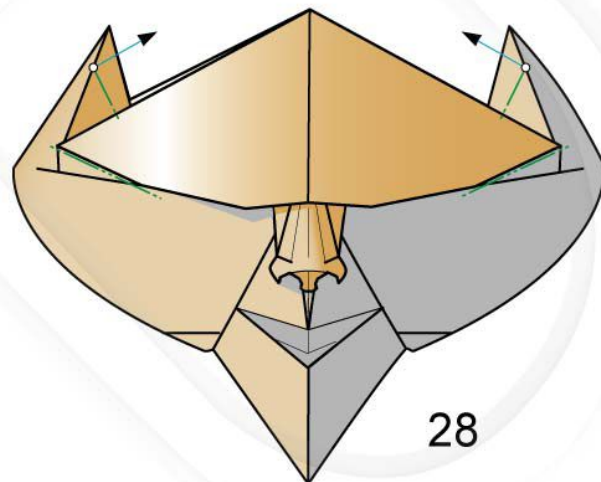

28

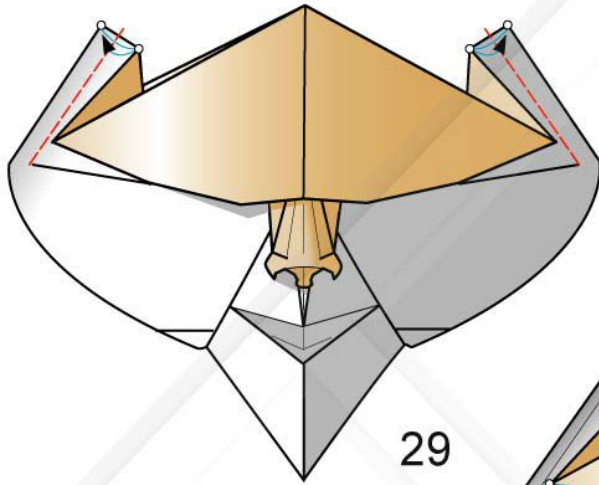

29

2 pieghe a valle

Ruotate

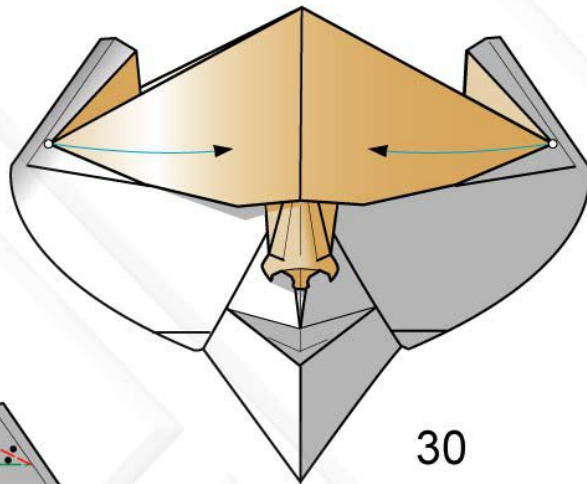

30

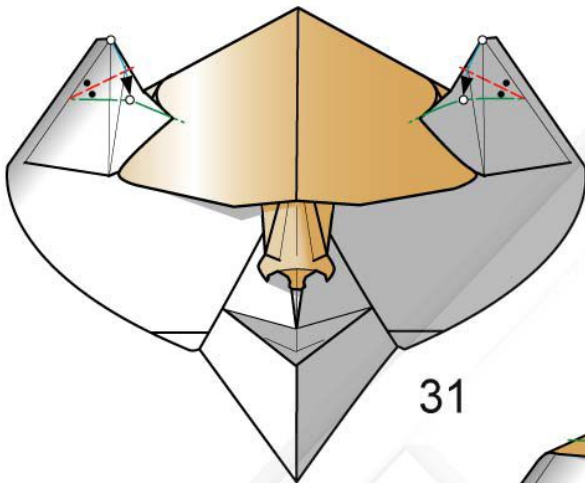

31

2 pieghe a monte, 2
bisettrici a valle e ruotate

2 pieghe a monte e
ruotate all'indietro

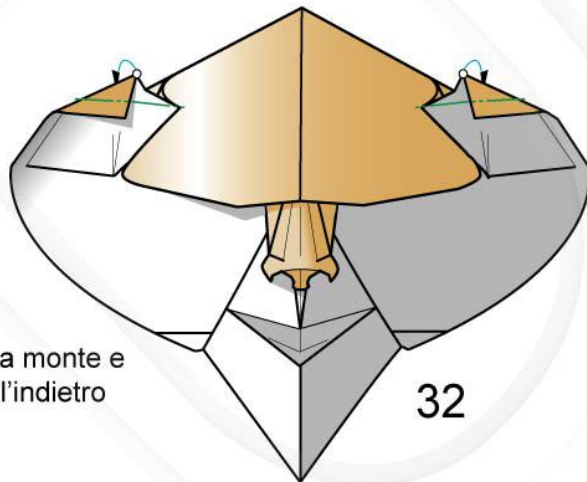

32

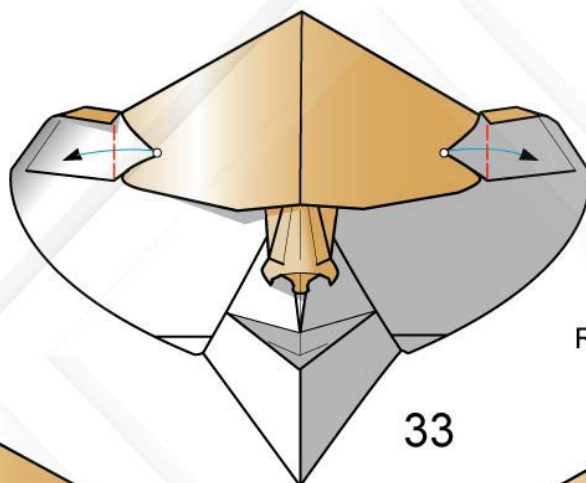

Ruotate

33

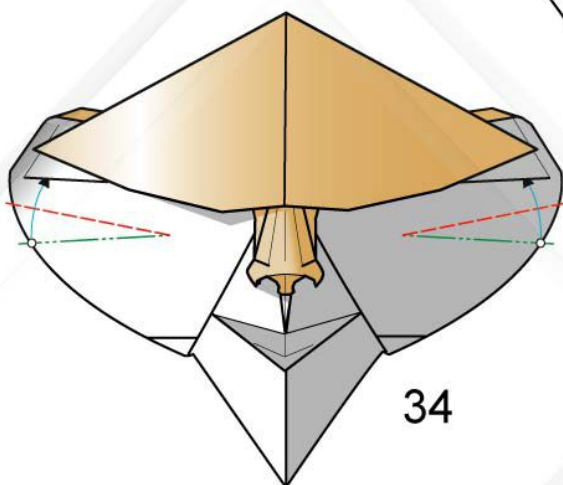

34

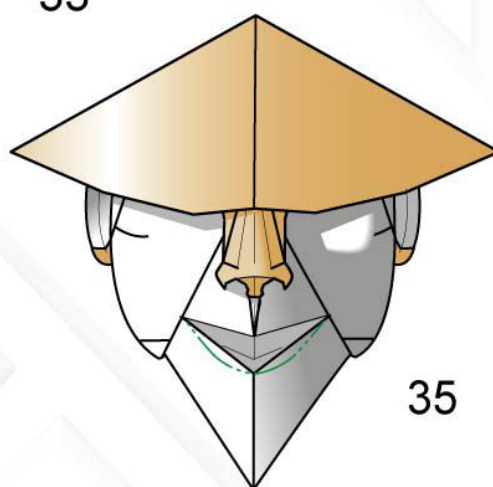

35

2 pieghe a valle, 2 a monte e ruotate 3D.
Prestate la massima attenzione nel
posizionamento e nella simmetria dei
punti di convergenza nelle guance

Mediante una piega a monte
curva arrotondate 3D la bocca

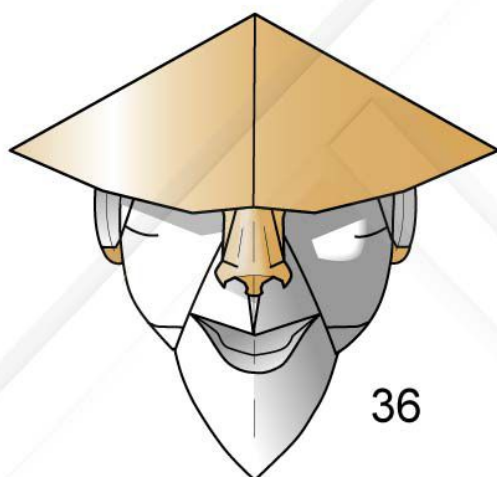

36

Maschera di Meo Lin ultimata

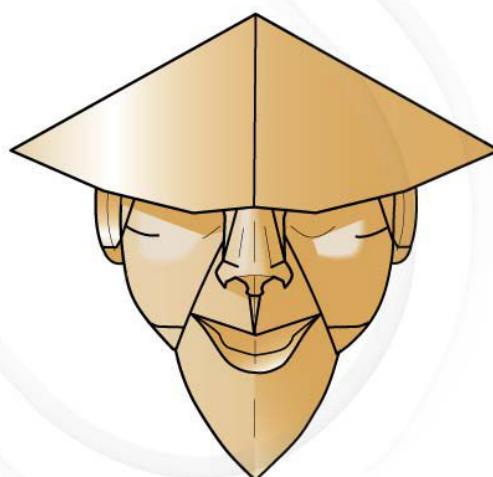

Maschera di Meo Lin ultimata
realizzata con cartoncino monocolore

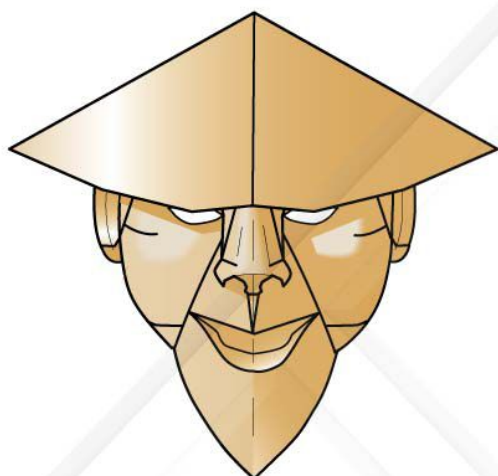

Maschera di Meo Lin
con occhi ritagliati

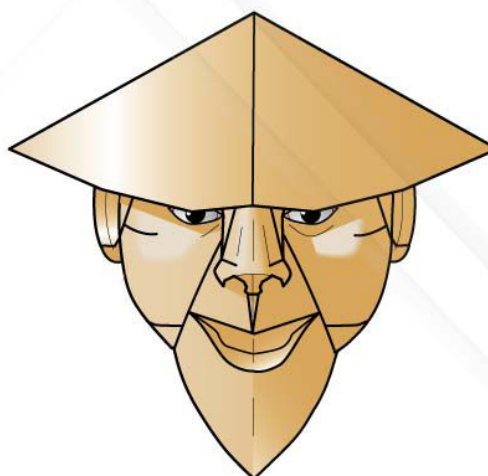

Maschera di Meo Lin con
occhi disegnati o incollati



VISTA DALL'ALTO



PROFILO



FRONTE



RETRO



VISTA DAL BASSO

VALENTINA



Ci si può immaginare un mondo privo di donne?....
Assolutamente NO.
Ecco allora Valentina. Non nascondo di aver trovato
difficoltà a realizzare una maschera caratterizzata
da lineamenti morbidi ed arrotondati.
Partite da un foglio di cartoncino quadrato
monocolore di 60 cm di lato.

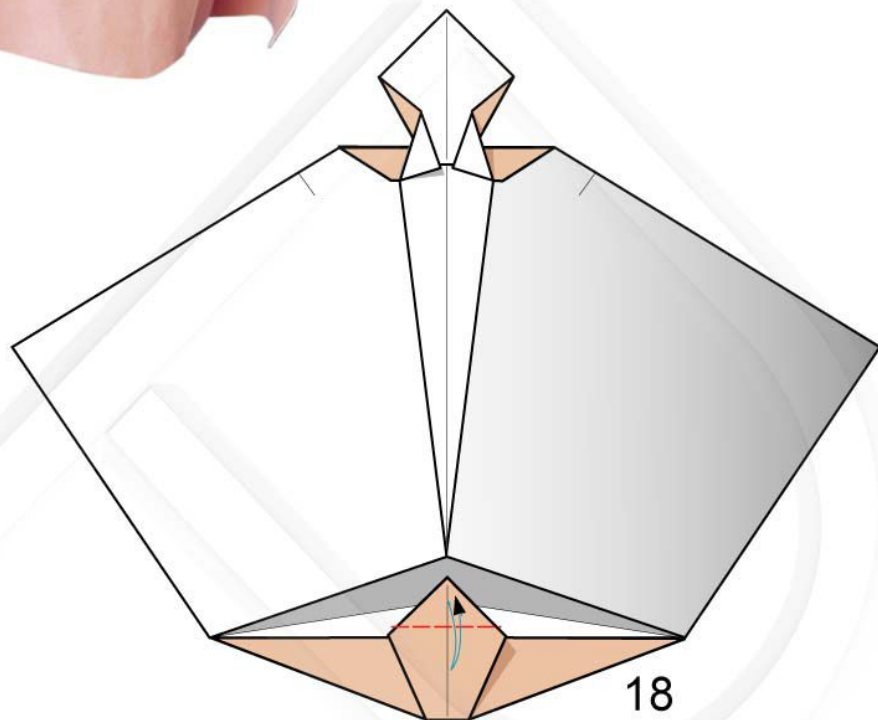

Partite dalla fig. n.17 di "Tutankamon".
1 piega a valle

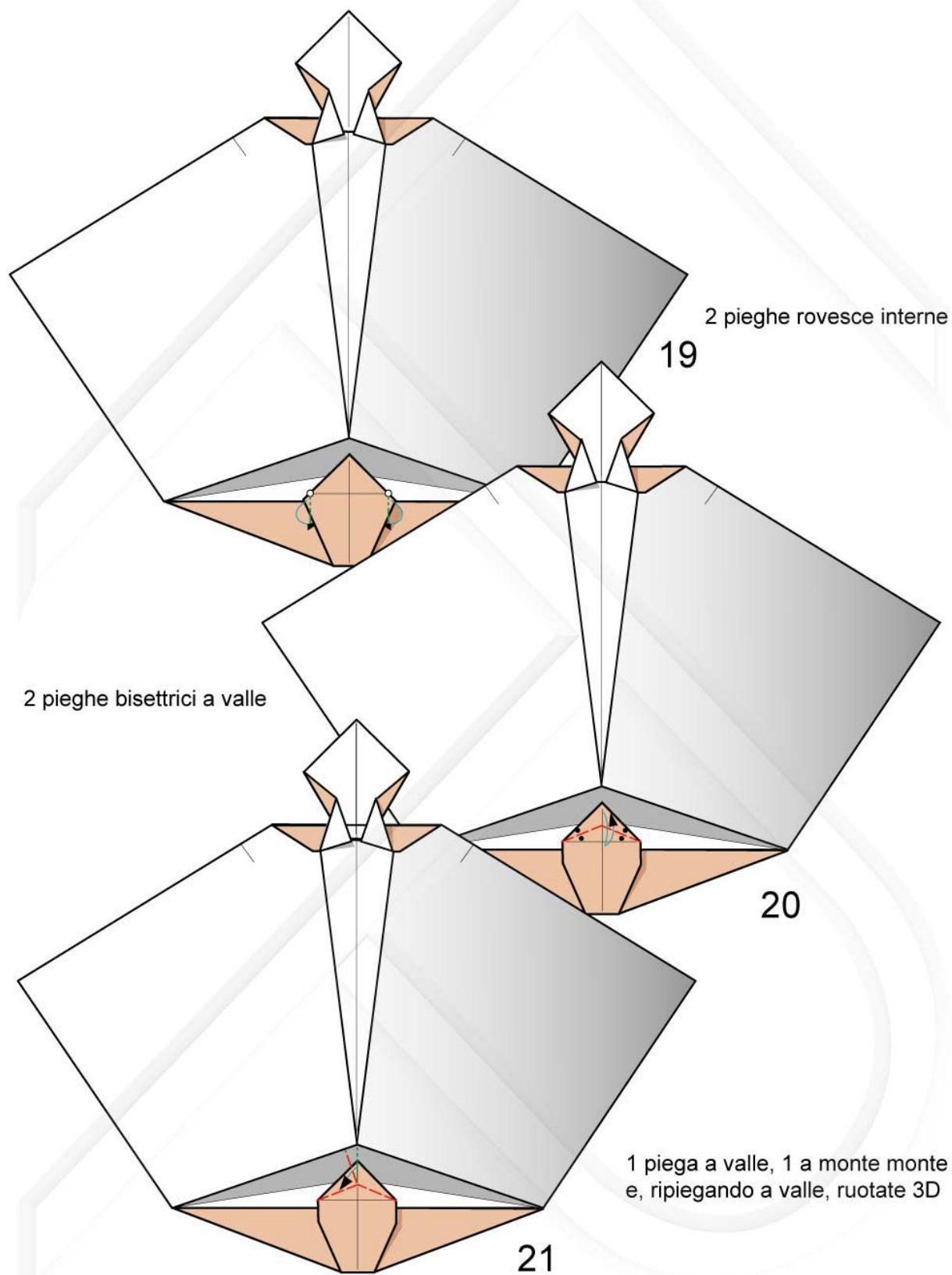

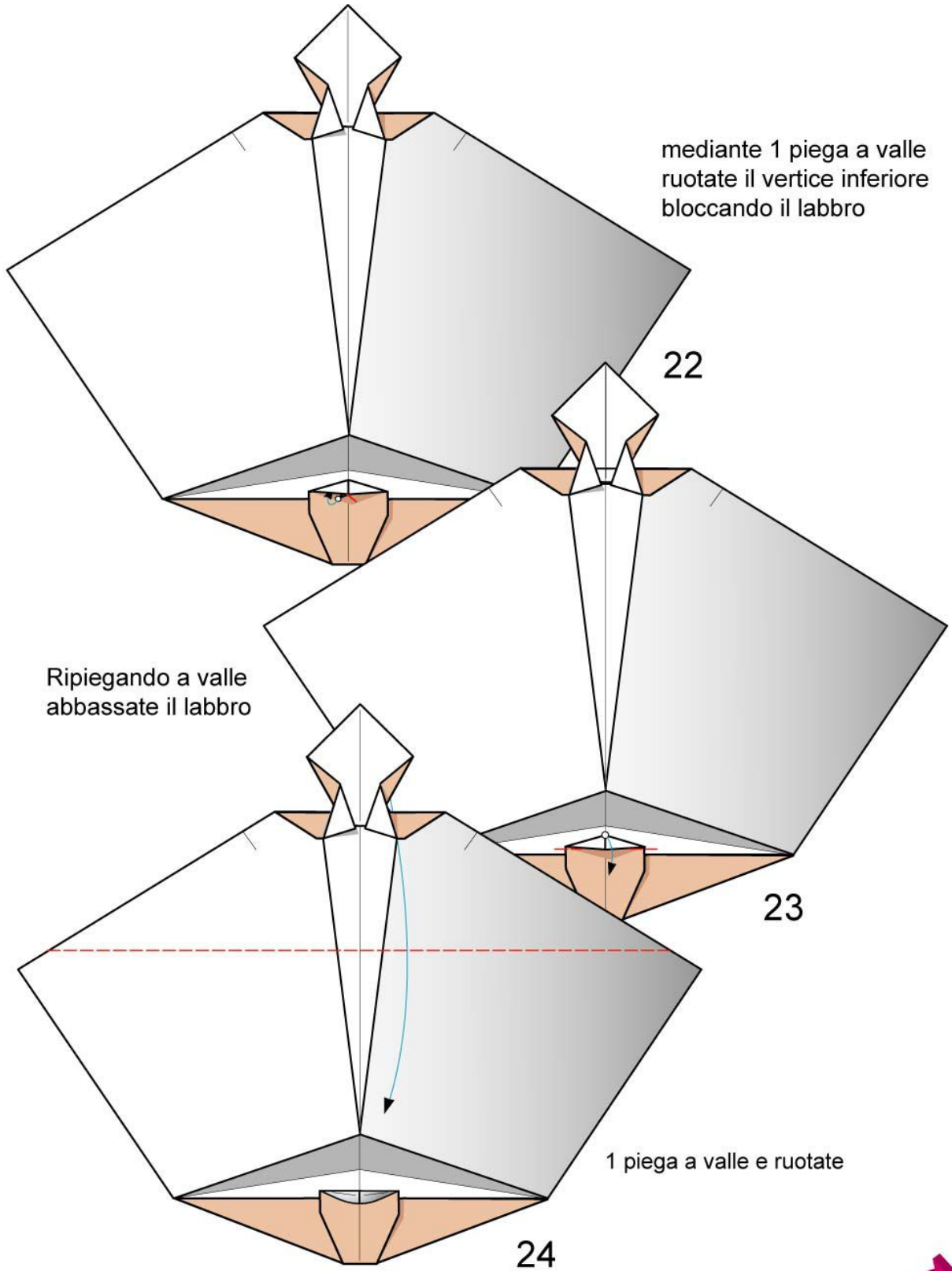

Disegni ingranditi 120 %



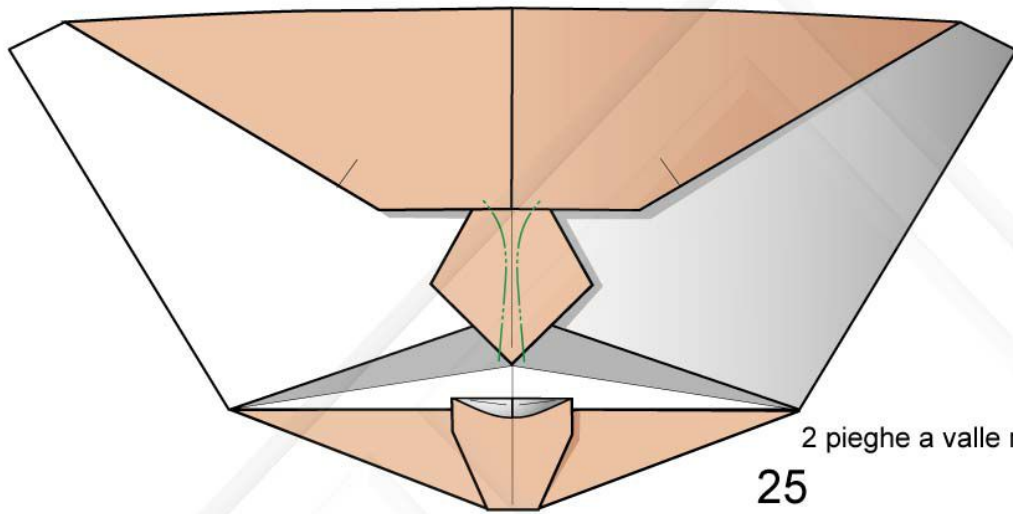

2 pieghe a valle morbide e curve

25

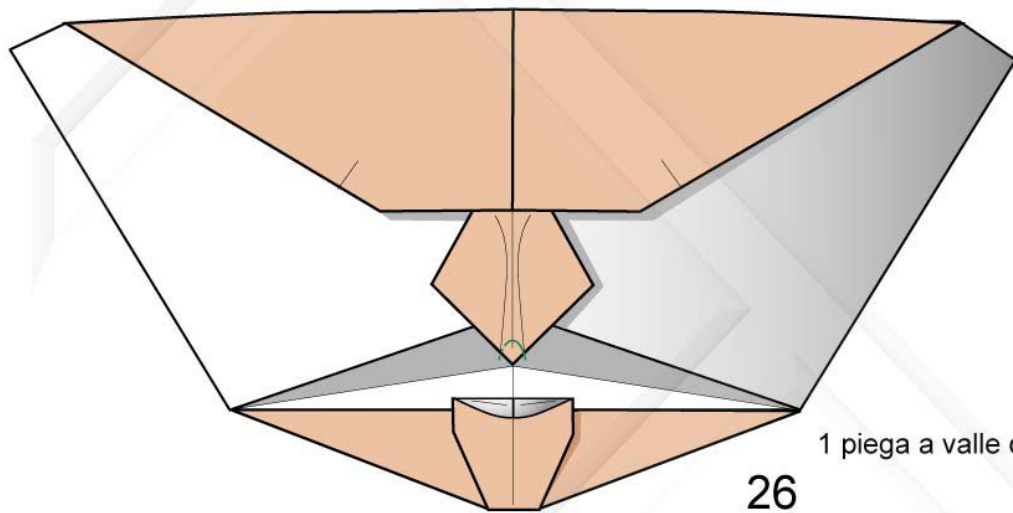

1 piega a valle curva

26

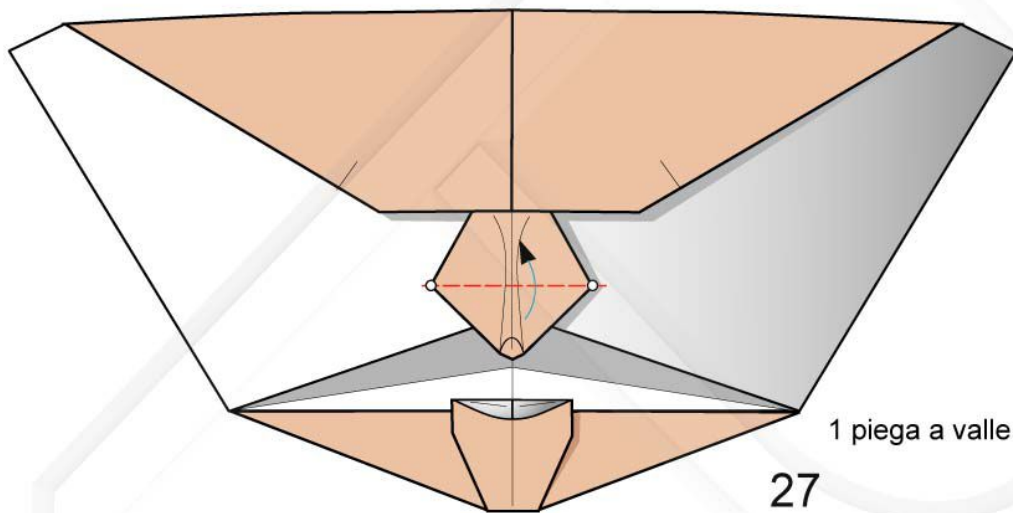

1 piega a valle e ruotate

27

106

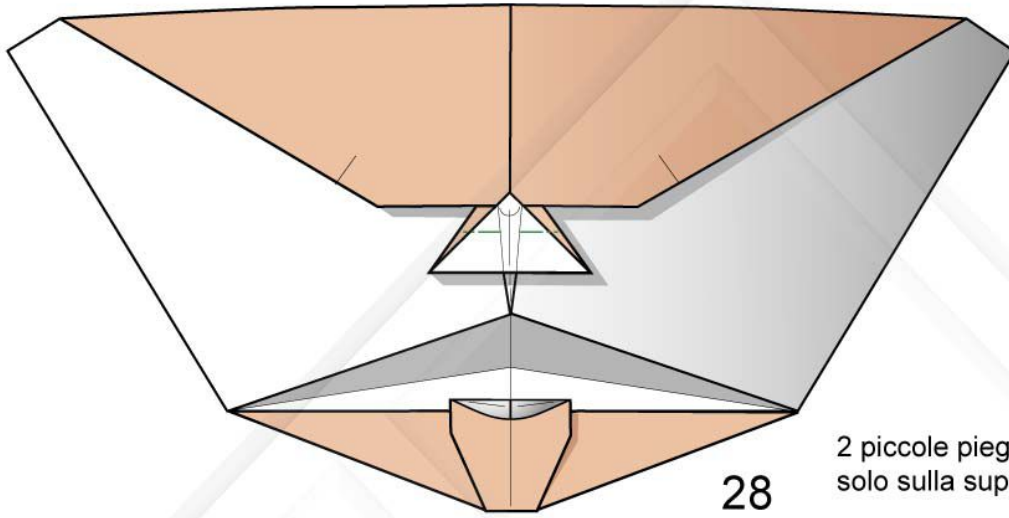

28

2 piccole pieghe a monte
solo sulla sup. in vista

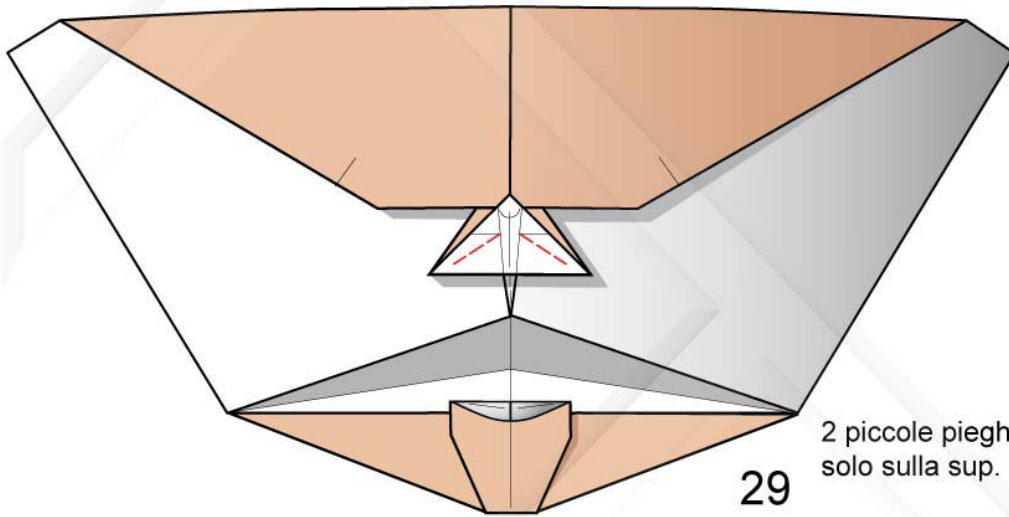

29

2 piccole pieghe a valle
solo sulla sup. in vista

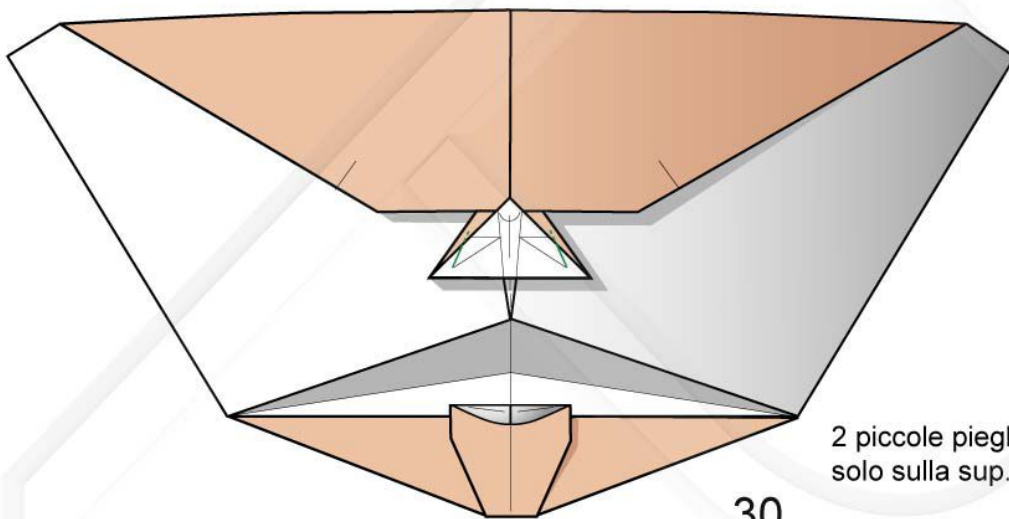

30

2 piccole pieghe a monte
solo sulla sup. in vista

107

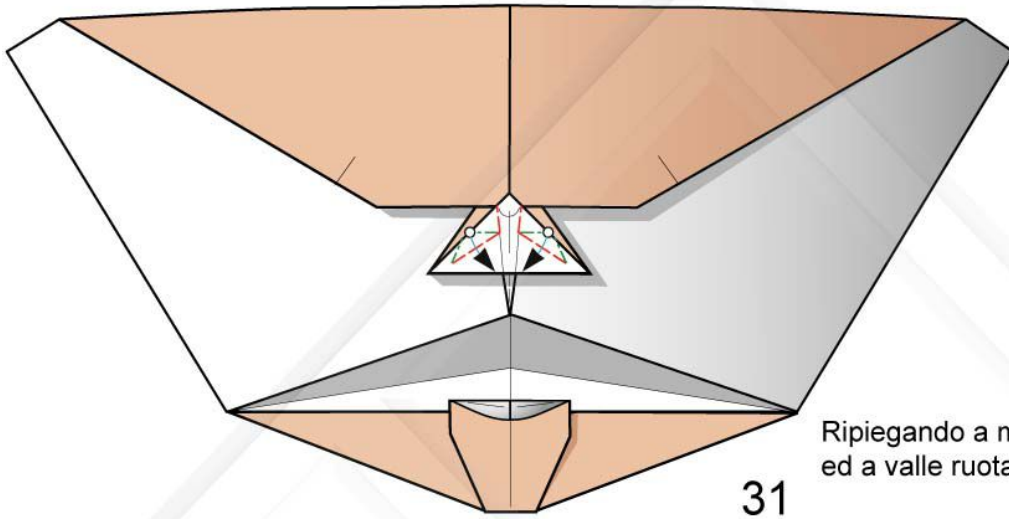

Ripiegando a monte ed a valle ruotate 3D

31

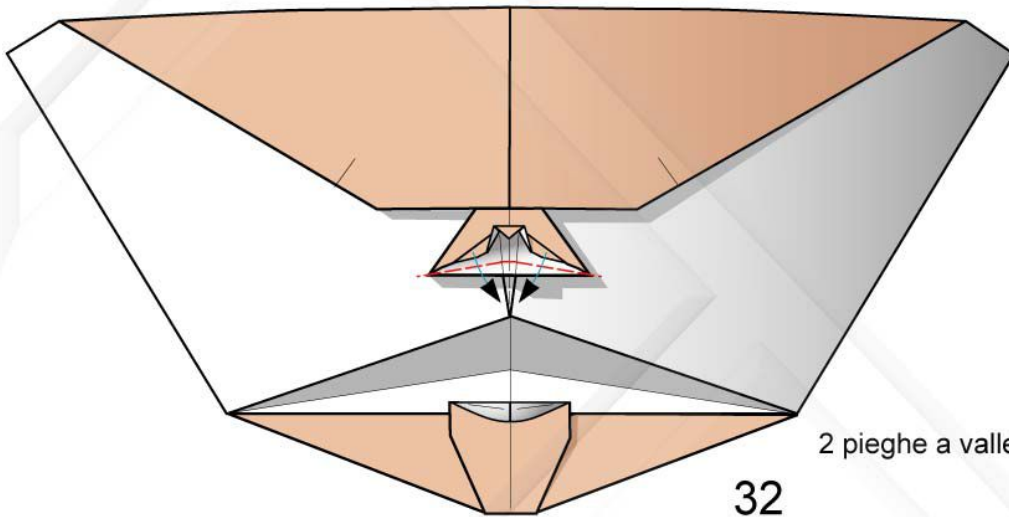

2 pieghe a valle ruotate 3D

32

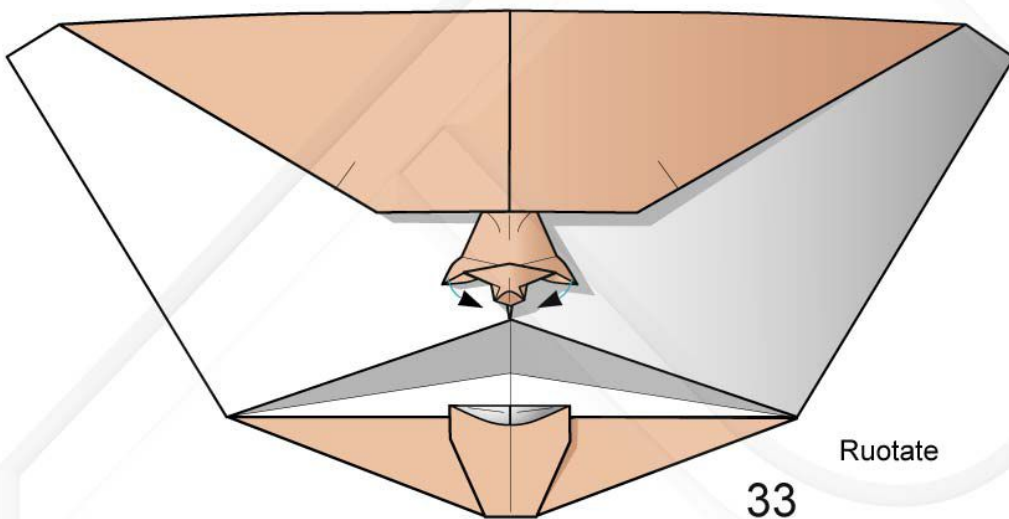

Ruotate

33

108

COSTRUZIONE DEL NASO



FRONTE APERTO



RETRO APERTO



RETRO



VISTA DAL BASSO



FRONTE



PROFILO

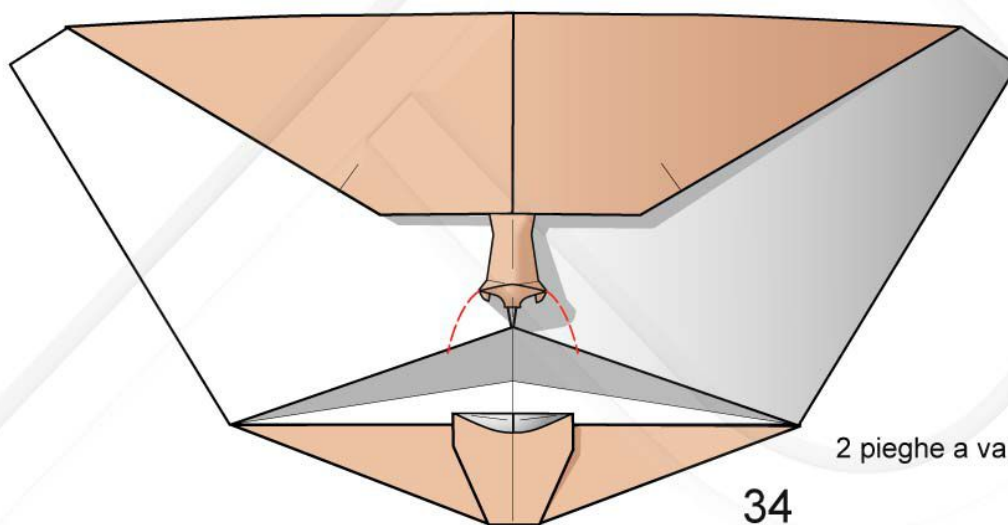

2 pieghe a valle

34

109

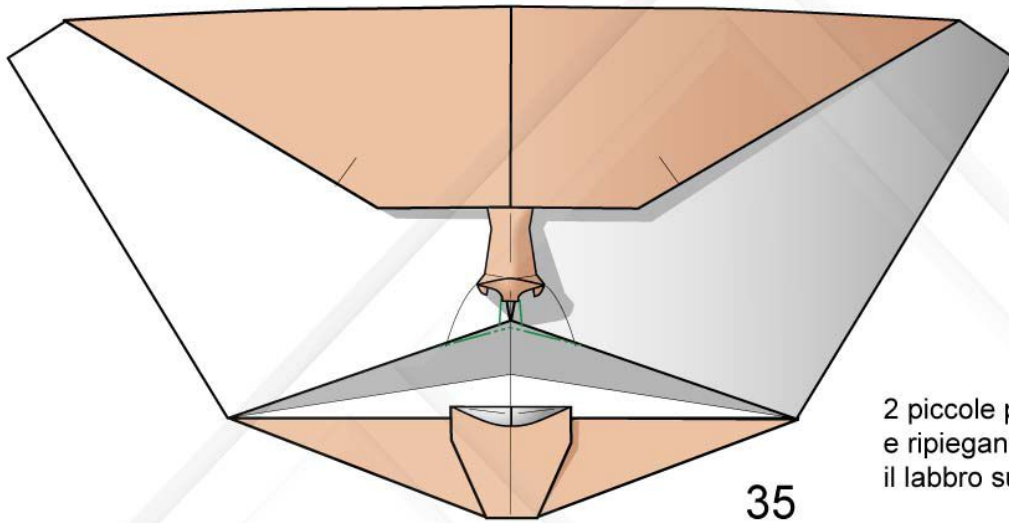

2 piccole pieghe a valle
e ripiegando modellate
il labbro superiore

35

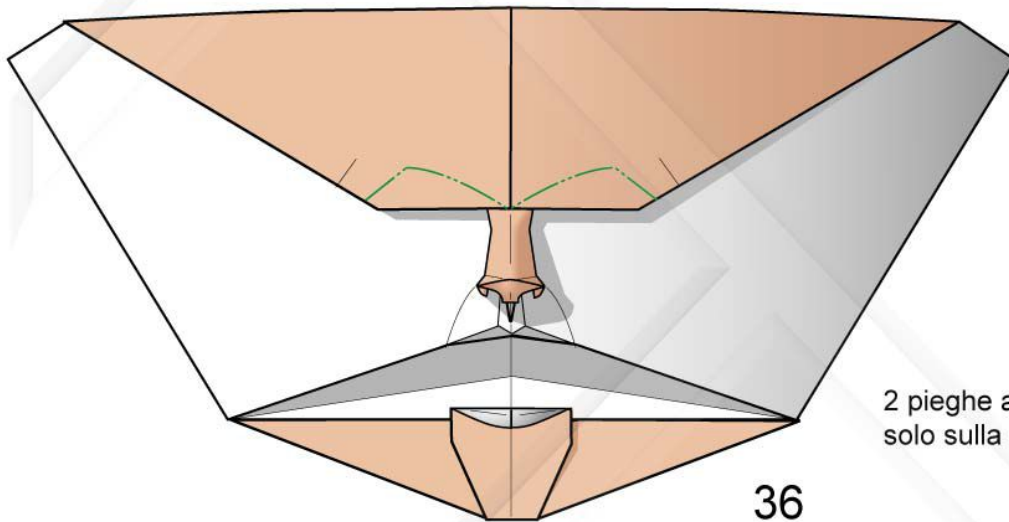

2 pieghe a monte curve
solo sulla sup. in vista

36

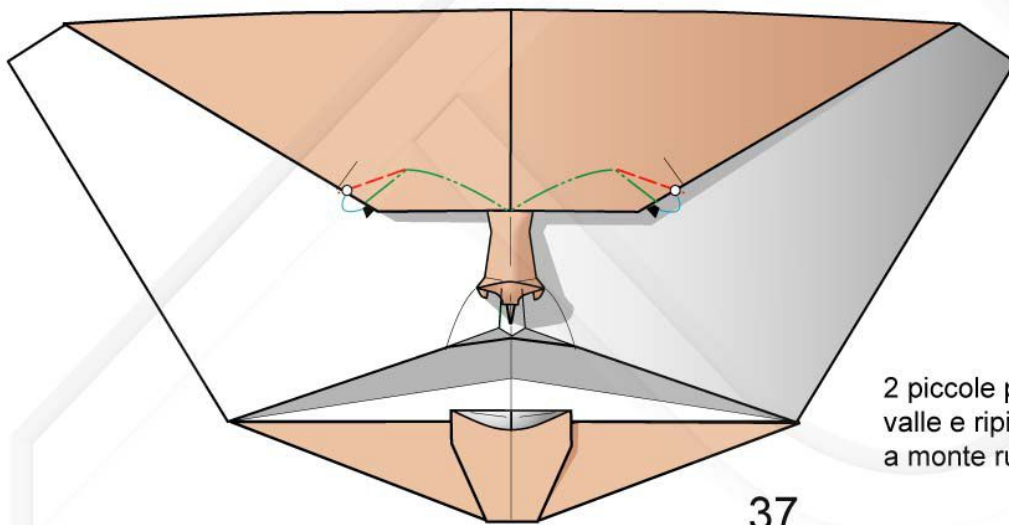

2 piccole pieghe a
valle e ripiegando
a monte ruotate 3D

37

110

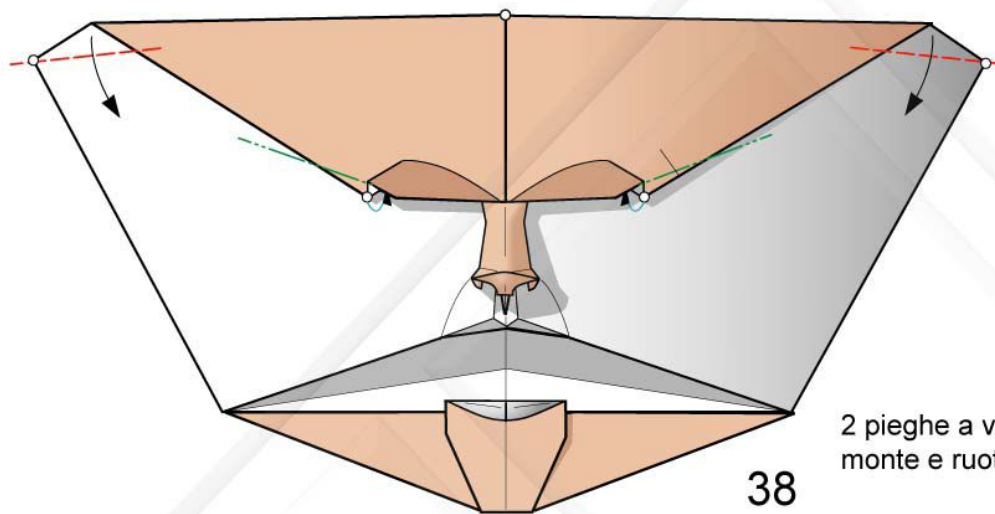

2 pieghe a valle, 2 a monte e ruotate 3D

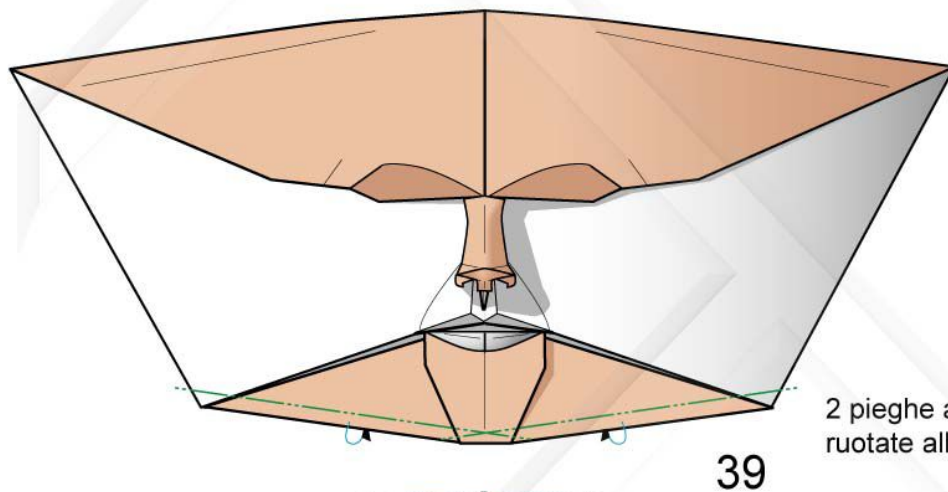

2 pieghe a monte e ruotate all'indietro

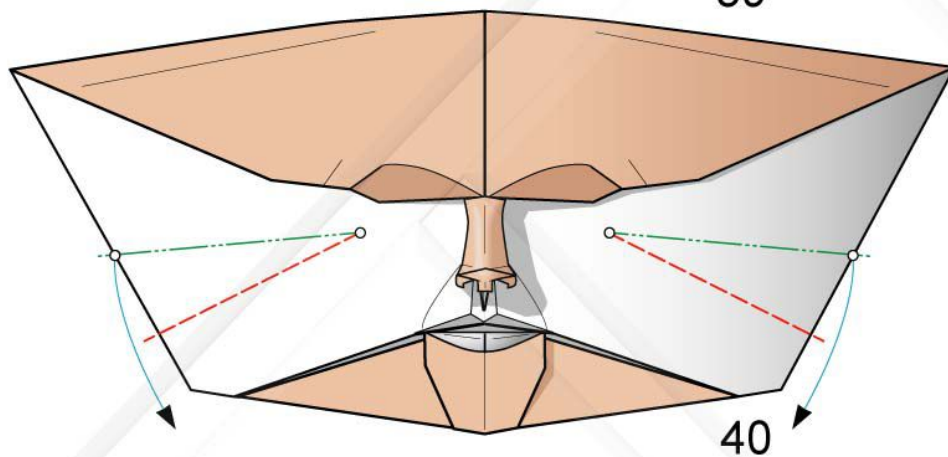

2 pieghe a valle, 2 a monte e ruotate 3D. Prestate la massima attenzione nel posizionamento e nella simmetria dei punti di convergenza nelle guance

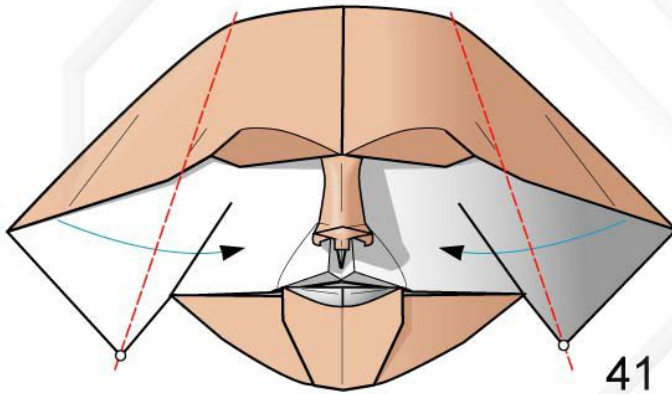

2 pieghe a valle e ruotate 3D

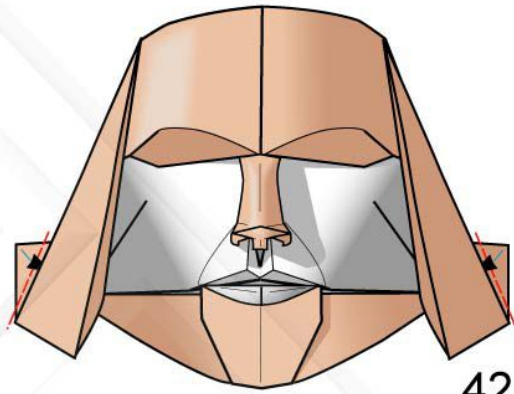

2 pieghe a valle e ruotate all'interno

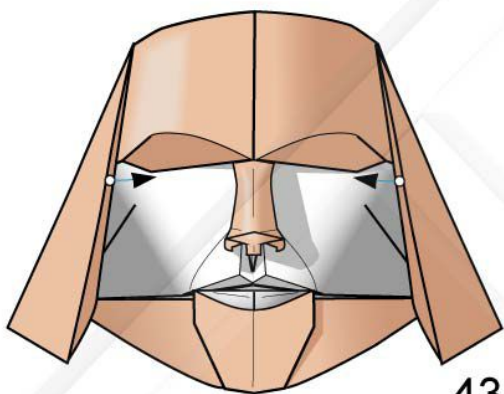

Estraete

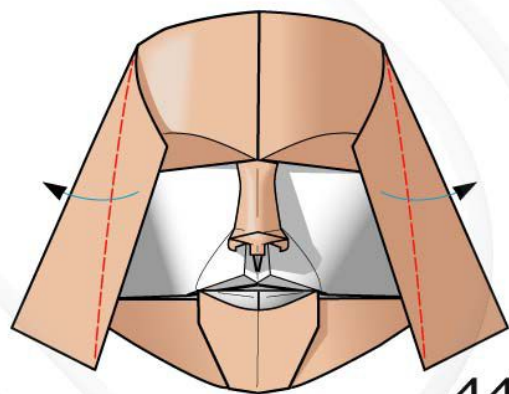

2 pieghe a valle e ruotate 3D

Disegni ingranditi 130 %



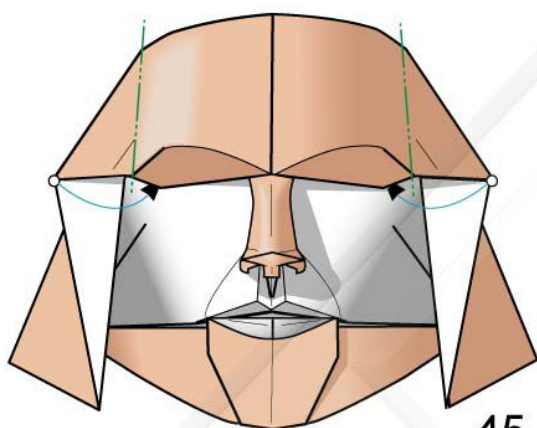

2 pieghe rovesce interne

45

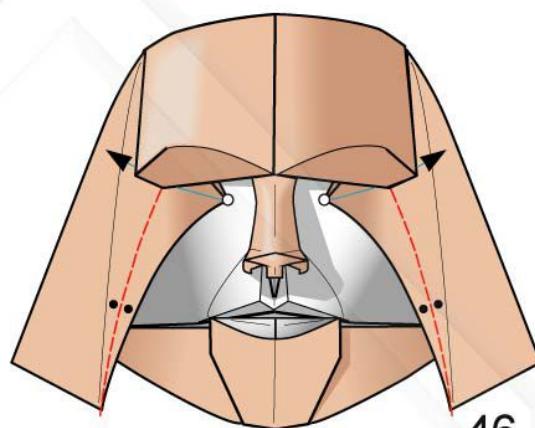

2 pieghe rovesce interne

46

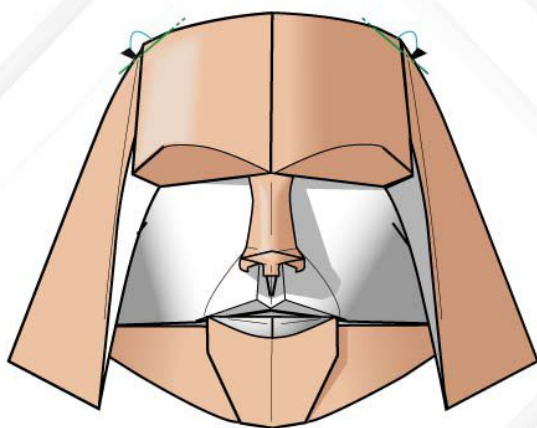

2 pieghe a monte e ruotate all'indietro

47

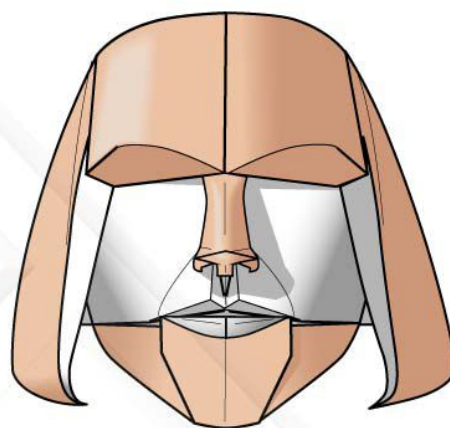

Maschera di Valentina ultimata

48

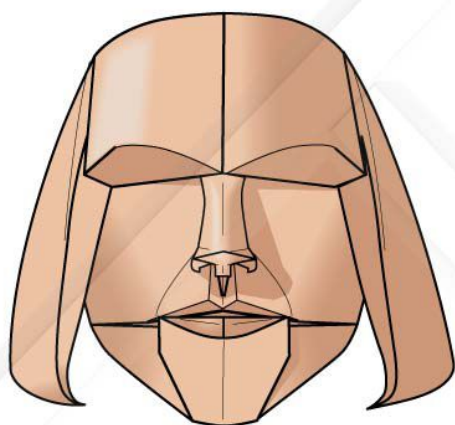

Maschera di Valentina ultimata realizzata con cartoncino monocoloro

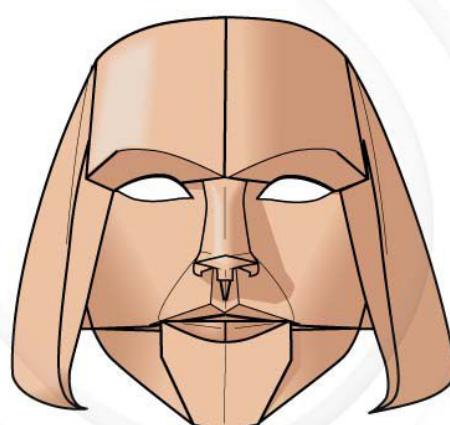

Maschera di Valentina con occhi ritagliati

Maschera di Valentina
con occhi disegnati o incollati

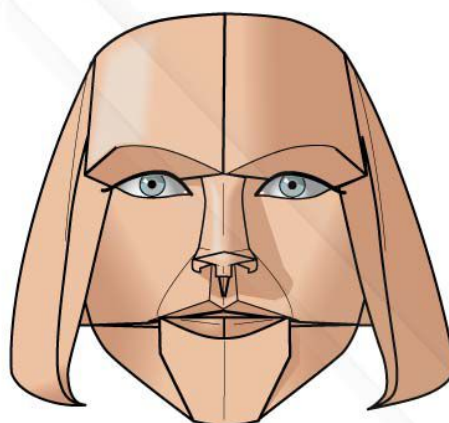

VISTA DALL'ALTO



PROFILO



FRONTE



RETRO



VISTA DAL BASSO

JENNY



Sorella di Valentina, si differenzia per la pettinatura più moderna che lascia scoperte le orecchie.

Partite da un foglio di cartoncino quadrato monocolore di 60 cm di lato.

Partite dalla fig. n. 39 di "Valentina" 4 pieghe a monte.

Prestate la massima attenzione nel posizionamento e nella simmetria dei punti di convergenza nelle guance

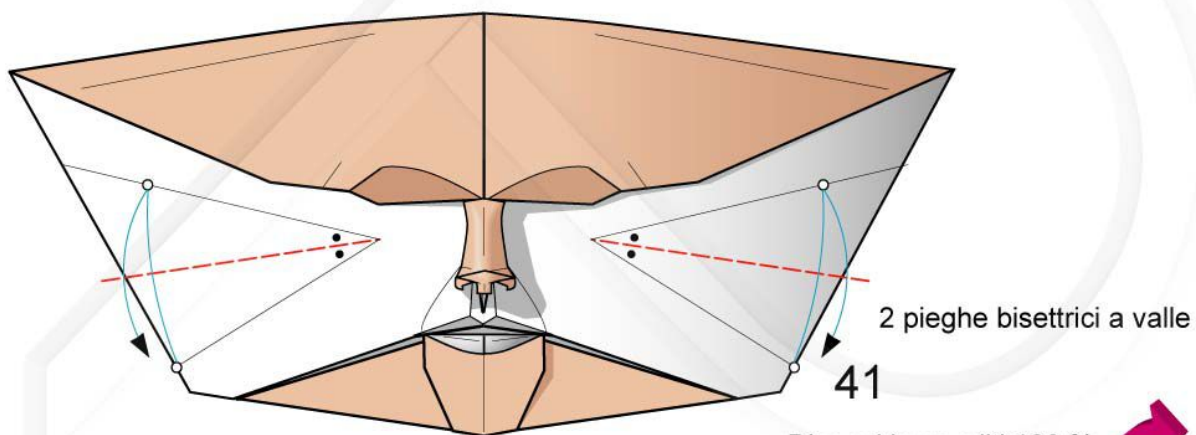
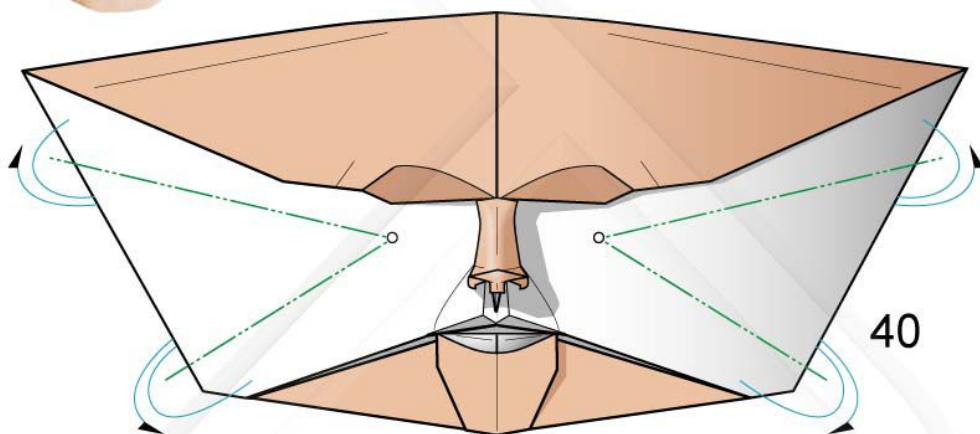

Disegni ingranditi 120 %



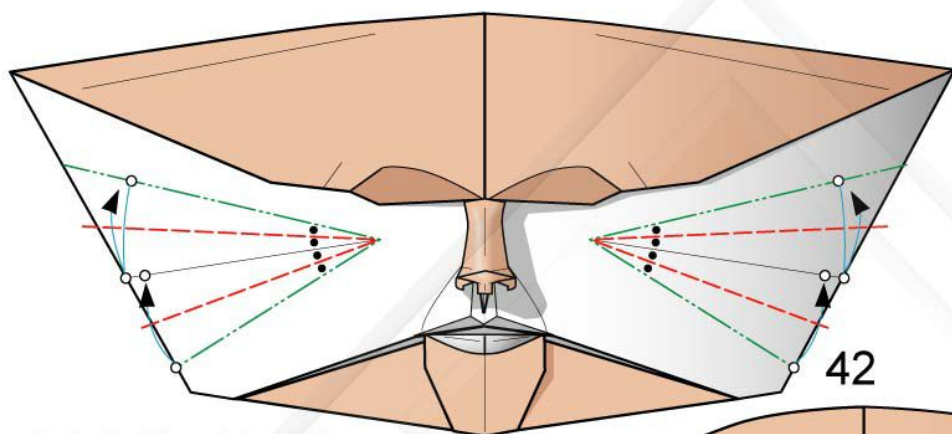

4 pieghe bisettrici a valle e ruotate ripiegando a monte

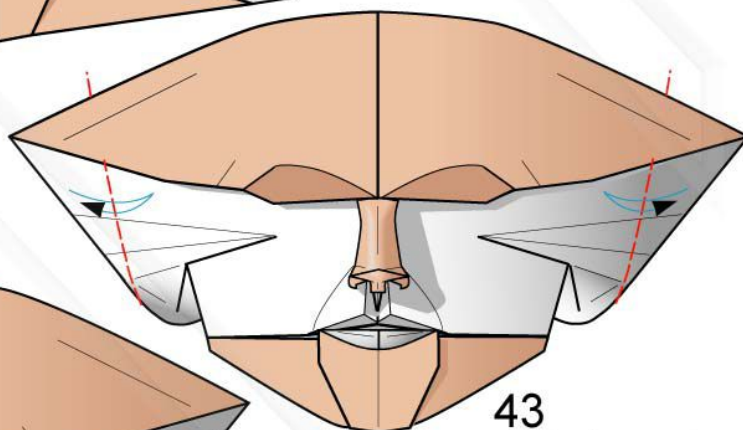

43
2 pieghe a valle

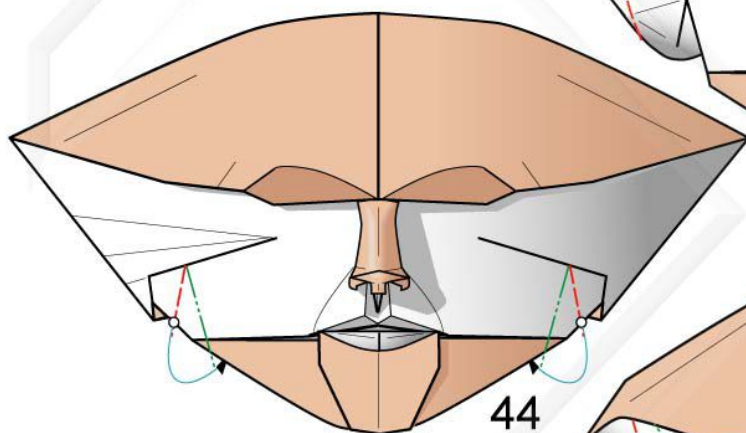

44
2 pieghe a valle, 2 a monte e ruotate 3D

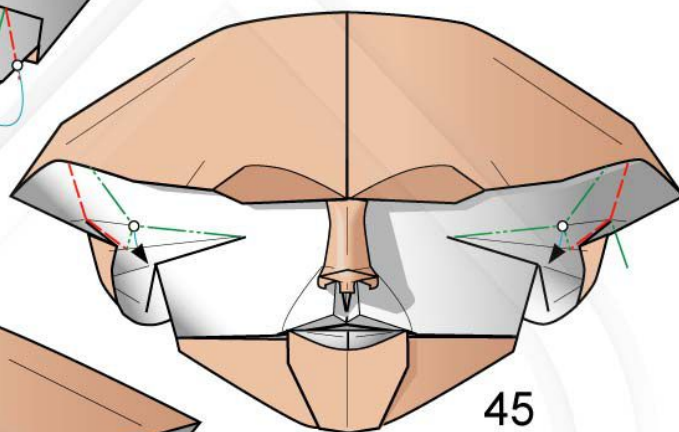

45
2 piccole pieghe a monte e ruotate ripiegando a valle

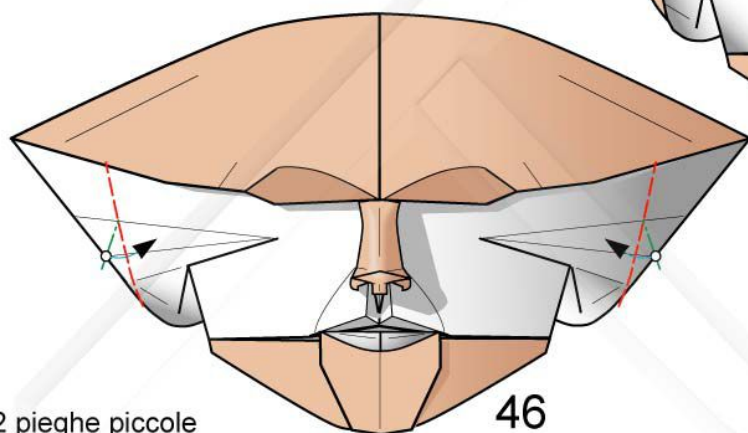

46
2 pieghe piccole pieghe a monte e ruotate 3D

Disegni ingranditi 130 % 

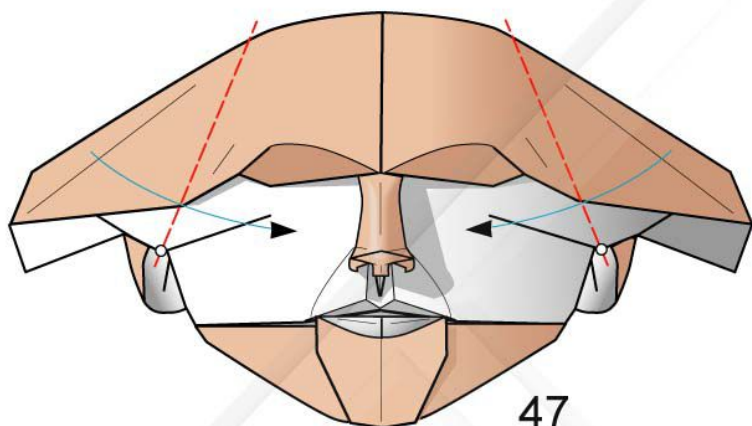

47

2 pieghe a valle e ruotate

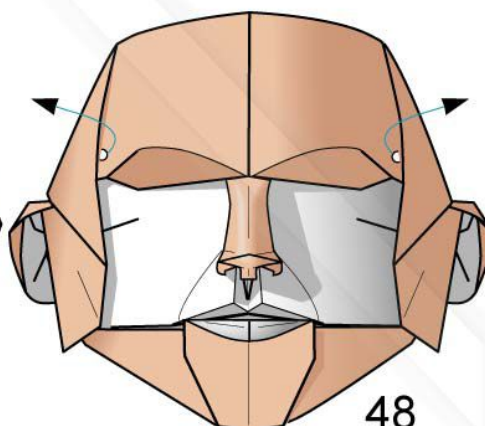

48

Estraete

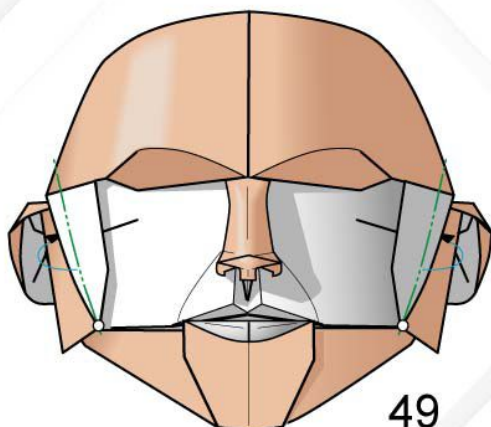

49

2 pieghe a monte solo
sulla sup.in vista e ruotate

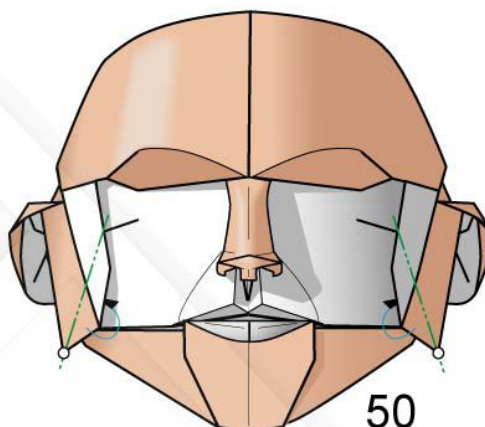

50

2 pieghe a monte e ruotate all'indietro

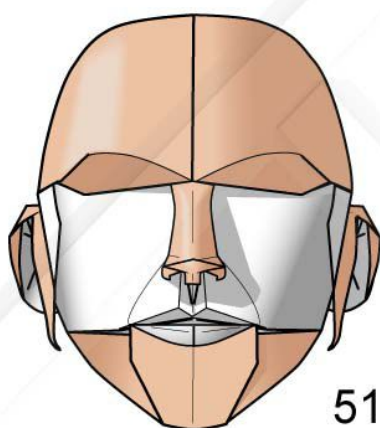

51

Maschera di Jenny ultimata

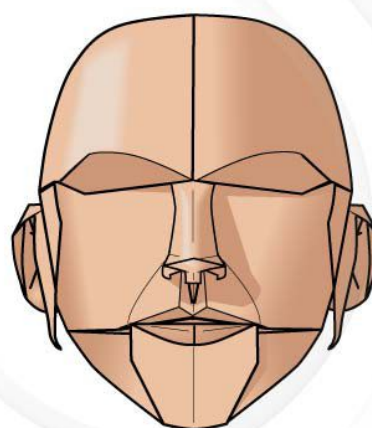

Maschera di Jenny ultimata
realizzata con cartoncino
monocolore

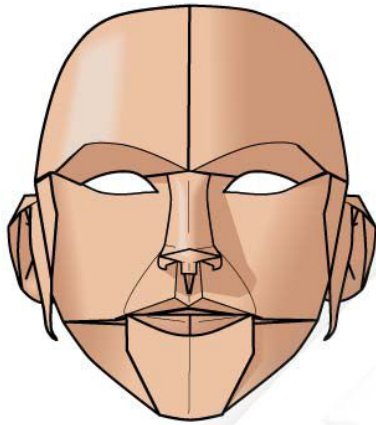

Maschera di Jenny
con occhi ritagliati

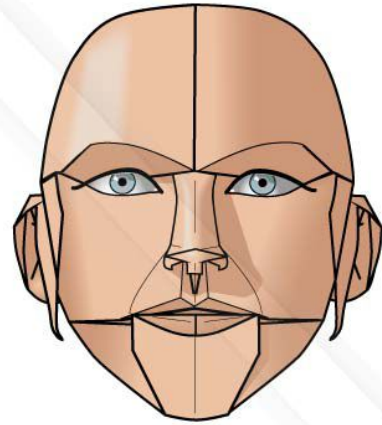

Maschera di Jenny
con occhi disegnati
o incollati



VISTA DALL'ALTO



PROFILO



FRONTE



RETRO



VISTA DAL BASSO

Occhi

Licantropus



Tutankamon



Spook

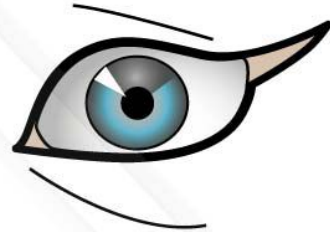
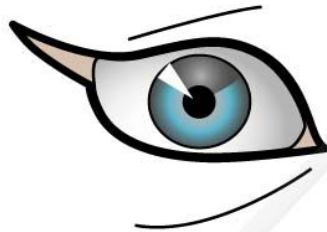

Jedi Joda



Caronte

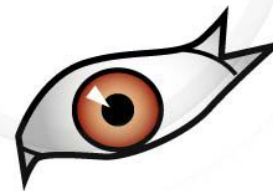
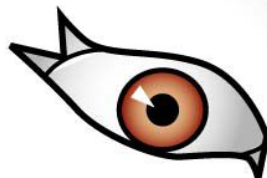

Skrr



Leonardo



Merlino



Meo Lin



Valentina,
Jenny, Jane



PUBBLICAZIONI DI FRANCO PAVARIN

Aerei , jet ed astronavi di carta volanti	IL CASTELLO	1986
Origami animati	“	1987
Origami maschere animate	”	1988
Decorazioni modulari con origami modulati	“	1989
Origami motoscafi navi barche e velieri	”	1990
Origami scatole e contenitori	“	1990
Pieghe forme e colori	”	1994
Aerei e navi di carta	FABBRI	1996
Fold and fly Paper airplanes	STERLING PUBLISHING	1998
Manuale rapido di aerei di carta volanti	FABBRI	2000
Aerei di carta 17 modelli volanti inediti	IL CASTELLO	2001
Aviones voladores	TUTOR S.A.	2003
17 modelos ineditos de aviones voladores	“	2004
Naves voladoras	”	2006
Quaderni Quadrato magico n.20 e 48	CDO	
Maschere, elmi e copricapi		2010
21 nuovi aerei origami volanti		2014
Maschere origami 3D		2014

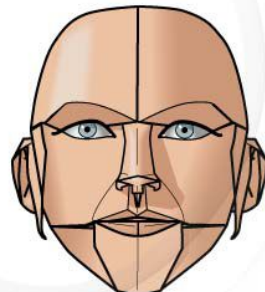
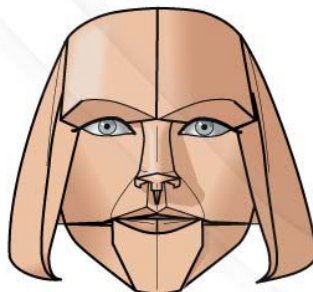
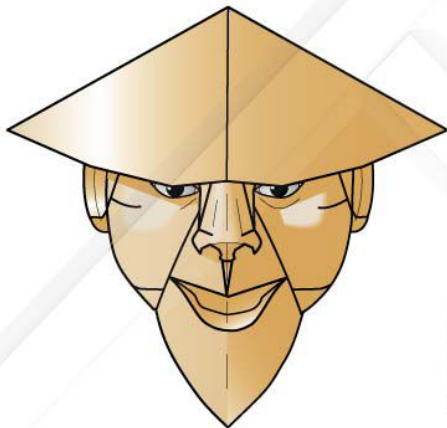
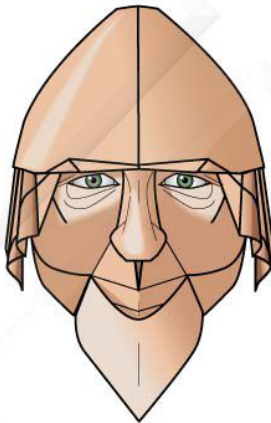
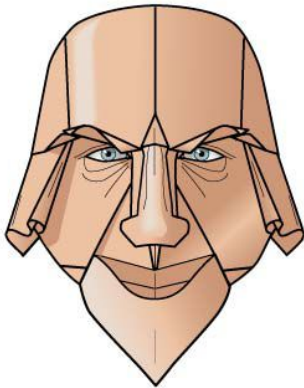
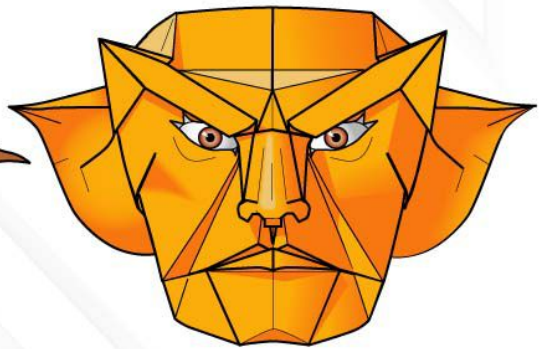
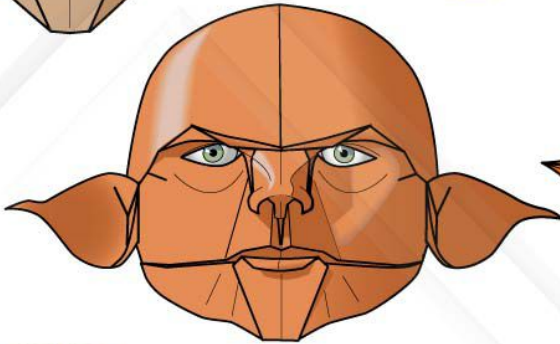
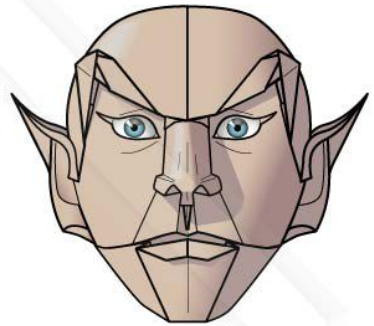
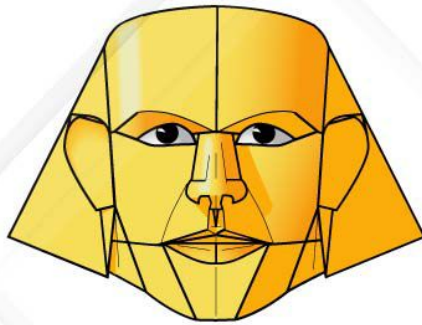
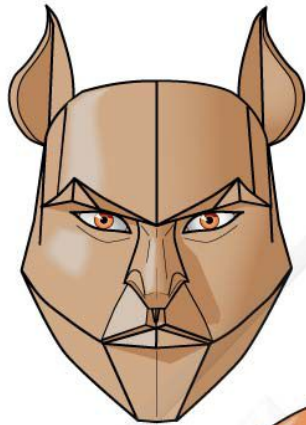

MASCHERE ORIGAMI 3D

Volume 1